



Testing Evaluation Laboratories, Inc.

2002 Wood Court Suite 1 – Plant City, FL 33563

Phone: 813-754-9887

ASTM E 1886-13a / ASTM E 1996-14a
Missile Level "D" (Includes Wind Zone 4)

TEST REPORT SUMMARY

Test Report Issued To:

Fleetwood Windows and Doors
1 Fleetwood Way
Corona, CA 92879

4400-T PIVOT DOOR

Title of Test	Results	
	Specimens 5a, 5b, 5c 1829 mm (72.00) x 3048 mm (120.00) – X	Specimen 6a 1829 mm (72.00) x 3048 mm (120.00) – X
Impact	Pass	Pass
Fatigue Load Cycling	+2873 /- 3112 Pa (+60.0/- 65.0 psf)	+2873 /- 3112 Pa (+60.0/- 65.0 psf)

Reference should be made to Report No. TEL 01993413 for complete test specimen description and data. For corresponding data regarding AAMA/WDMA/CSA 101/I.S./2/A440-17 reference should be made to Report No. TEL 01993412.

For Testing Evaluation Laboratories, Inc.

Vivian K. Wright,
President



Testing Evaluation Laboratories, Inc.

2002 Wood Court Suite 1 – Plant City, FL 33563
Phone: 813-754-9887

TEST RESULTS

IAS Lab Certification Number: TL-299

Report No: TEL 01993413
Test Dates: November 2-8, 2021
Report Date: December 14, 2021

Issued to:

Fleetwood Windows and Doors
One Fleetwood Way
Corona, CA 92879

Project Summary: Testing Evaluation Laboratories, Inc. (TEL) was contracted by Fleetwood Windows and Doors to perform tests on the 4400-T Pivot Door at TEL's Plant City, FL test facility.

Test specimen descriptions and results are reported herein.

Test Specifications: The test specimens were evaluated in accordance with the following:

ASTM E 1886-13a / ASTM E 1996-14a
Missile Level "D" (Includes Wind Zone 4)

Test Specimen Description:

Series / Model:	4400-T Pivot Door
Type:	Impact Resistant Aluminum Pivot Doors
Overall Size:	1829 mm x 3048 mm (72.0" x 120.0") – X – Specimens 5a, 5b, 5c, 6a
Daylight Opening:	1568 mm x 2772 mm (61.75 x 109.125") – Specimens 5a, 5b, 5c, 6a
Glazing Detail:	(See attached drawing #L-9491, #L-9495 and #L-9496 for details)
Frame Material:	Aluminum
Finish:	Mill Finish

For Tested Elevation, Vertical Cross Sections, Horizontal Cross Sections, Components, Frame Anchoring, Glazing Detail and Bill of Materials See Attached Drawing #'s L-9495 and 9496.

Test Results: Specimen 5a 1829 mm x 3048 mm (72.0" x 120.0") – 4400-T Pivot Door

ASTM E1886 (13a) / ASTM E1996 (14a) - Large Missile Impact (2 x 4 Southern Yellow Pine)

Conditioning Temperature:		Missile Weight: (Level D) Excluding Wind Zone 4		Missile Length:		Muzzle Distance:	
24° C	(76.0° F)	4.03 Kg	(8 lbs 14 oz.)	2.40 m	7'-10"	5.23 m	17'2"

Impact Location	Results	(X) Measurement		(Y) Measurement		Speed	
		mm	inches	mm	inches	m/s	fps
Center of Door Panel	Pass	889	35.00	1473	58.00	15.3	50.1
Lower Right Corner of Door Panel	Pass	1524	60.00	318	12.50	15.2	49.7

Observations: Missile impacted @ X, Y coordinates fracturing exterior and interior lites with no rupture of interlayer

Positive % of Test Load	Positive Pressure Range						Number Of Cycles	Average Cycle Time (Seconds)
	Pa	to	Pa	(psf)	to	(psf)		
20% to 50%	575	to	1436	12.0	to	30.0	3500	1.34
0% to 60%	0	to	1724	0.0	to	36.0	300	2.51
50% to 80%	1436	to	2298	30.0	to	48.0	600	1.45
30% to 100%	862	to	2873	18.0	to	60.0	100	2.38

Observations: Glass deflected 92 mm (3.63") from original plane @ 100% Positive Load

Negative % of Test Load	Negative Pressure Range						Number Of Cycles	Average Cycle Time (Seconds)
	Pa	to	Pa	(psf)	to	(psf)		
30% to 100%	934	to	3112	19.5	to	65.0	50	2.09
50% to 80%	1556	to	2490	32.5	to	52.0	1050	1.30
0% to 60%	0	to	1436	0.0	to	39.0	50	1.71
20% to 50%	622	to	1556	13.0	to	32.5	3350	1.31

Observations: Glass deflected 108 mm (4.25") from original plane @ 100% Positive Load

- Note:
1. Orientation of missile at impact was within +/- 5° of horizontal.
 2. "X" measurement is from left edge of test specimen.
 3. "Y" measurement is from bottom edge of test specimen.
 4. At the completion of test there were no tears in the interlayer.

Test Technician: Christian Seifried

Test Results: Specimen 5b 1829 mm x 3048 mm (72.0" x 120.0") – 4400-T Pivot Door

ASTM E1886 (13a) / ASTM E1996 (14a) - Large Missile Impact (2 x 4 Southern Yellow Pine)

Conditioning Temperature:		Missile Weight: (Level D) Excluding Wind Zone 4		Missile Length:		Muzzle Distance:	
24° C	(76.0° F)	4.03 Kg	(8 lbs 14 oz.)	2.40 m	7'-10"	5.23 m	17'2"

Impact Location	Results	(X) Measurement		(Y) Measurement		Speed	
		mm	inches	mm	inches	m/s	fps
Center of Door Panel	Pass	914	36.00	1524	60.00	15.2	50.0
Lower Right Corner of Door Panel	Pass	1511	59.50	305	12.00	15.2	49.7

Observations: Missile impacted @ X, Y coordinates fracturing exterior and interior lites with no rupture of interlayer

Positive % of Test Load	Positive Pressure Range						Number Of Cycles	Average Cycle Time (Seconds)
	Pa	to	Pa	(psf)	to	(psf)		
20% to 50%	575	to	1436	12.0	to	30.0	3500	1.60
0% to 60%	0	to	1724	0.0	to	36.0	300	1.79
50% to 80%	1436	to	2298	30.0	to	48.0	600	1.23
30% to 100%	862	to	2873	18.0	to	60.0	100	1.41

Observations: Glass deflected 99 mm (3.88") from original plane @ 100% Positive Load

Negative % of Test Load	Negative Pressure Range						Number Of Cycles	Average Cycle Time (Seconds)
	Pa	to	Pa	(psf)	to	(psf)		
30% to 100%	934	to	3112	19.5	to	65.0	50	2.46
50% to 80%	1556	to	2490	32.5	to	52.0	1050	1.20
0% to 60%	0	to	1436	0.0	to	39.0	50	2.88
20% to 50%	622	to	1556	13.0	to	32.5	3350	1.34

Observations: Glass deflected 89 mm (3.50") from original plane @ 100% Positive Load

- Note:
1. Orientation of missile at impact was within +/- 5° of horizontal.
 2. "X" measurement is from left edge of test specimen.
 3. "Y" measurement is from bottom edge of test specimen.
 4. At the completion of test there were no tears in the interlayer.

Test Technician: Christian Seifried

Test Results: Specimen 5c 1829 mm x 3048 mm (72.0" x 120.0") – 4400-T Pivot Door

ASTM E1886 (13a) / ASTM E1996 (14a) - Large Missile Impact (2 x 4 Southern Yellow Pine)

Conditioning Temperature:		Missile Weight: (Level D) Excluding Wind Zone 4		Missile Length:		Muzzle Distance:	
24° C	(76.0° F)	4.03 Kg	(8 lbs 14 oz.)	2.40 m	7'-10"	5.23 m	17'2"

Impact Location	Results	(X) Measurement		(Y) Measurement		Speed	
		mm	inches	mm	inches	m/s	fps
Center of Door Panel	Pass	914	36.00	1524	60.00	15.3	50.1
Upper Left Corner of Door Panel	Pass	305	12.00	2743	108.00	15.2	49.9

Observations: Missile impacted @ X, Y coordinates fracturing exterior and interior lites with no rupture of interlayer

Positive % of Test Load	Positive Pressure Range						Number Of Cycles	Average Cycle Time (Seconds)
	Pa	to	Pa	(psf)	to	(psf)		
20% to 50%	575	to	1436	12.0	to	30.0	3500	1.38
0% to 60%	0	to	1724	0.0	to	36.0	300	2.30
50% to 80%	1436	to	2298	30.0	to	48.0	600	1.37
30% to 100%	862	to	2873	18.0	to	60.0	100	1.52

Observations: Glass deflected 89 mm (3.50") from original plane @ 100% Positive Load

Negative % of Test Load	Negative Pressure Range						Number Of Cycles	Average Cycle Time (Seconds)
	Pa	to	Pa	(psf)	to	(psf)		
30% to 100%	934	to	3112	19.5	to	65.0	50	2.29
50% to 80%	1556	to	2490	32.5	to	52.0	1050	1.16
0% to 60%	0	to	1436	0.0	to	39.0	50	2.95
20% to 50%	622	to	1556	13.0	to	32.5	3350	1.50

Observations: Glass deflected 105 mm (4.13") from original plane @ 100% Positive Load

- Note:
1. Orientation of missile at impact was within +/- 5° of horizontal.
 2. "X" measurement is from left edge of test specimen.
 3. "Y" measurement is from bottom edge of test specimen.
 4. At the completion of test there were no tears in the interlayer.

Test Technician: Christian Seifried

Test Results: Specimen 6a 1829 mm x 3048 mm (72.0" x 120.0") – 4400-T Pivot Door

ASTM E1886 (13a) / ASTM E1996 (14a) - Large Missile Impact (2 x 4 Southern Yellow Pine)

Conditioning Temperature:		Missile Weight: (Level D) Excluding Wind Zone 4		Missile Length:		Muzzle Distance:	
24° C	(76.0° F)	4.03 Kg	(8 lbs 14 oz.)	2.40 m	7'-10"	5.23 m	17'2"

Impact Location	Results	(X) Measurement		(Y) Measurement		Speed	
		mm	inches	mm	inches	m/s	fps
Center of Door Panel	Pass	921	36.25	1549	61.00	15.2	49.8
Lower Right Corner of Door Panel	Pass	1537	60.50	298	11.75	15.2	50.0

Observations: Missile impacted @ X, Y coordinates fracturing exterior and interior lites with no rupture of interlayer

Positive % of Test Load	Positive Pressure Range						Number Of Cycles	Average Cycle Time (Seconds)
	Pa	to	Pa	(psf)	to	(psf)		
20% to 50%	575	to	1436	12.0	to	30.0	3500	1.45
0% to 60%	0	to	1724	0.0	to	36.0	300	2.45
50% to 80%	1436	to	2298	30.0	to	48.0	600	1.61
30% to 100%	862	to	2873	18.0	to	60.0	100	1.85

Observations: Glass deflected 99 mm (3.88") from original plane @ 100% Positive Load

Negative % of Test Load	Negative Pressure Range						Number Of Cycles	Average Cycle Time (Seconds)
	Pa	to	Pa	(psf)	to	(psf)		
30% to 100%	934	to	3112	19.5	to	65.0	50	2.00
50% to 80%	1556	to	2490	32.5	to	52.0	1050	1.15
0% to 60%	0	to	1436	0.0	to	39.0	50	2.25
20% to 50%	622	to	1556	13.0	to	32.5	3350	1.32

Observations: Glass deflected 121 mm (4.75") from original plane @ 100% Positive Load

- Note:
1. Orientation of missile at impact was within +/- 5° of horizontal.
 2. "X" measurement is from left edge of test specimen.
 3. "Y" measurement is from bottom edge of test specimen.
 4. At the completion of test there were no tears in the interlayer.

Test Technician: Christian Seifried

General Note:

Tape and film were used to seal against air leakage during fatigue loading/cycling. In our opinion, the tape and film did not influence the results of the tests.

Drawing Reference

The test specimen drawings have been reviewed by TEL and are representative of the test specimens reported herein.

Conditions, Terms, and General Notes Regarding These Tests

The product tested Has Been compared to the detailed drawing, bill of materials and fabrication information supplied by the client so named herein. Our analysis, which includes dimensional and component description comparisons, indicate the tested product and engineering information supplied by the client "Are Equivalent".

The report and representative samples will be retained for four years from the date of initial test.

These test results were obtained by employing all requirements of the designated test methods with no Deviations unless explicitly noted in test report. The test results and specimen supplied for testing are in compliance with the reference.

The test results are specific to the product tested by this laboratory and of the sample supplied by the client named herein, and they relate to no other product either manufactured by the client, a fabricator of the client or of installed field performance.

This test report does not constitute certification of this product, but only that the above test results were obtained using the designated test methods and they indicate compliance with the performance requirements (paragraphs as listed) of the above referenced specifications.

Testing Evaluation Laboratories, Inc. makes no opinions or endorsements regarding this product and its performance. This report may not be reproduced or quoted in partial form without the expressed written approval of Testing Evaluation Laboratories, Inc.

Testing Evaluation Laboratories, Inc.'s letter, reports, its name or insignia or mark are for the exclusive use of the client so named herein and any other use is strictly prohibited. The report, letters and the name of Testing Evaluation Laboratories, Inc., its seal or mark shall not be used in any circumstance to the general public or in any advertising.

Limitation of liability: Due diligence was used in performing the tests and reporting the results. By acceptance of this report, this client agrees to hold harmless and indemnify Testing Evaluation Laboratories, Inc., its employees, sub-contractors and officers and owners against all claims and demands of any kind whatsoever, which arise out of or in any manner connected with the performance of work referred to herein.

Testing Evaluation Laboratories, Inc.

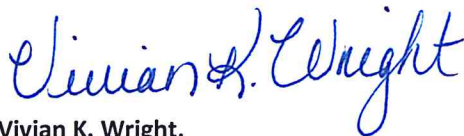

Vivian K. Wright,
President

Revision Log

Rev No.	Date	Page(s)	Revision(s)
0	12/14/2021	NA	Original Report Issue

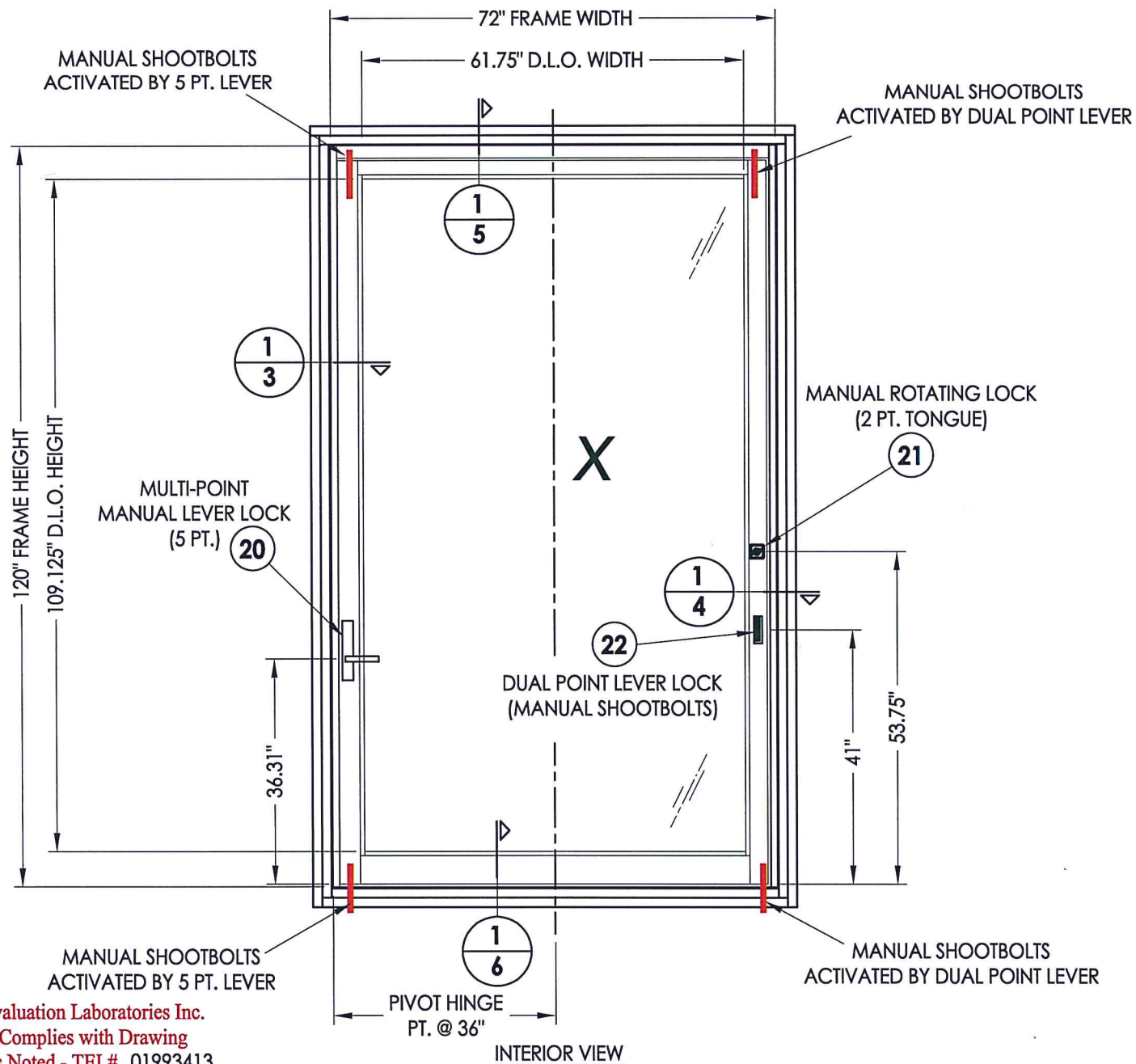

Testing Evaluation Laboratories Inc.
Specimen Complies with Drawing
Deviations Noted - TEL# 01993413
Date 12/14/2021 Verified by VKW

PRODUCT:		FLEETWOOD SPEC. 5, 5a, 5b, 5c	
PART OR ASSEMBLY:		TEST ELEVATION	
NO.	DATE	REVISIONS	BY
 RW BUILDING CONSULTANTS, INC. 813.659.9197			
DATE: 11/04/21			
SCALE: N.T.S.			
DWG. BY: LFS			
CHK. BY: RW			
DRAWING NO.: L-9495			
SHEET 2 OF 10			

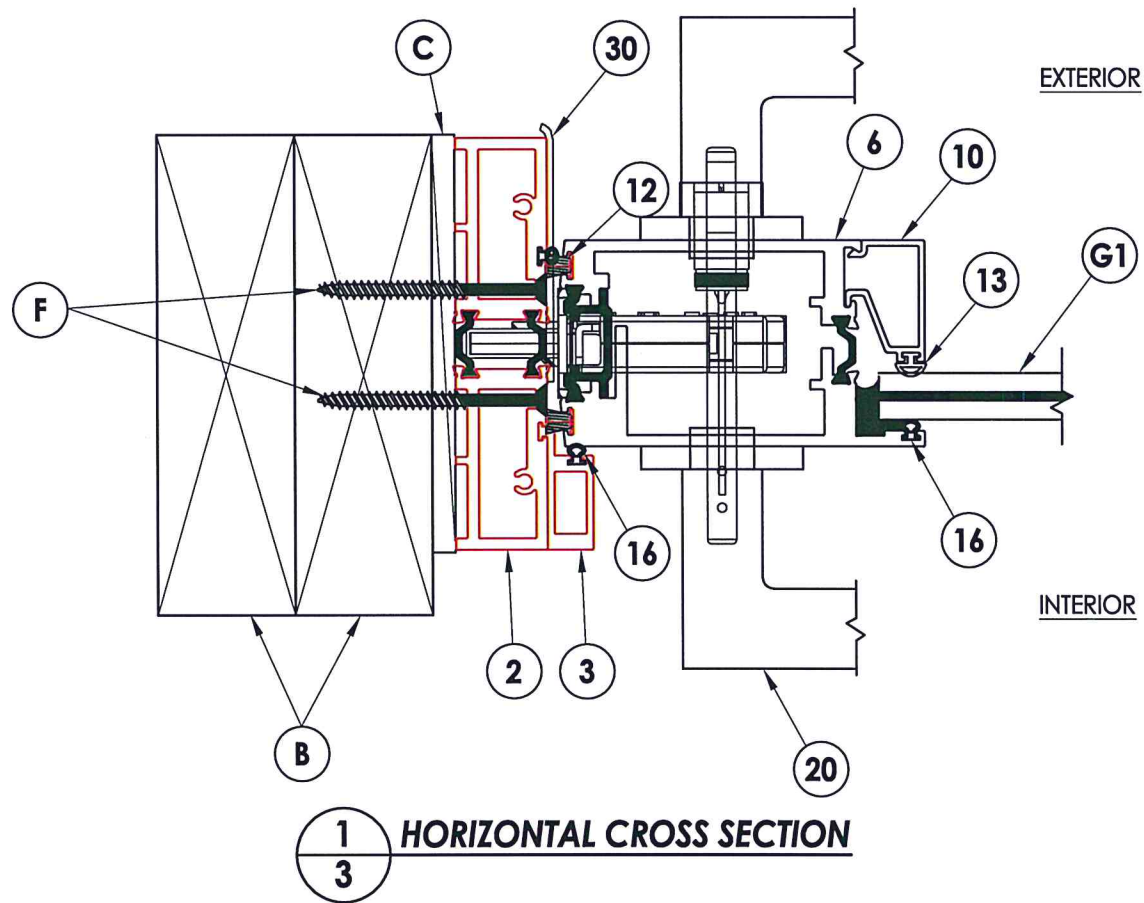

1
3
HORIZONTAL CROSS SECTION

PRODUCT:		FLEETWOOD SPEC. 5, 5a, 5b, 5c	
PART OR ASSEMBLY:		HORIZONTAL CROSS SECTION	
NO.	DATE	REVISIONS	BY
 RW BUILDING CONSULTANTS, INC. 813.659.9197			
DATE: 11/04/21			
SCALE: N.T.S.			
DWG. BY: LFS			
CHK. BY: RW			
DRAWING NO.: L-9495			
SHEET 3 OF 10			

Testing Evaluation Laboratories Inc.
 Specimen Complies with Drawing
 Deviations Noted - TEL# 01993413
 Date 12/14/2021 Verified by VKW

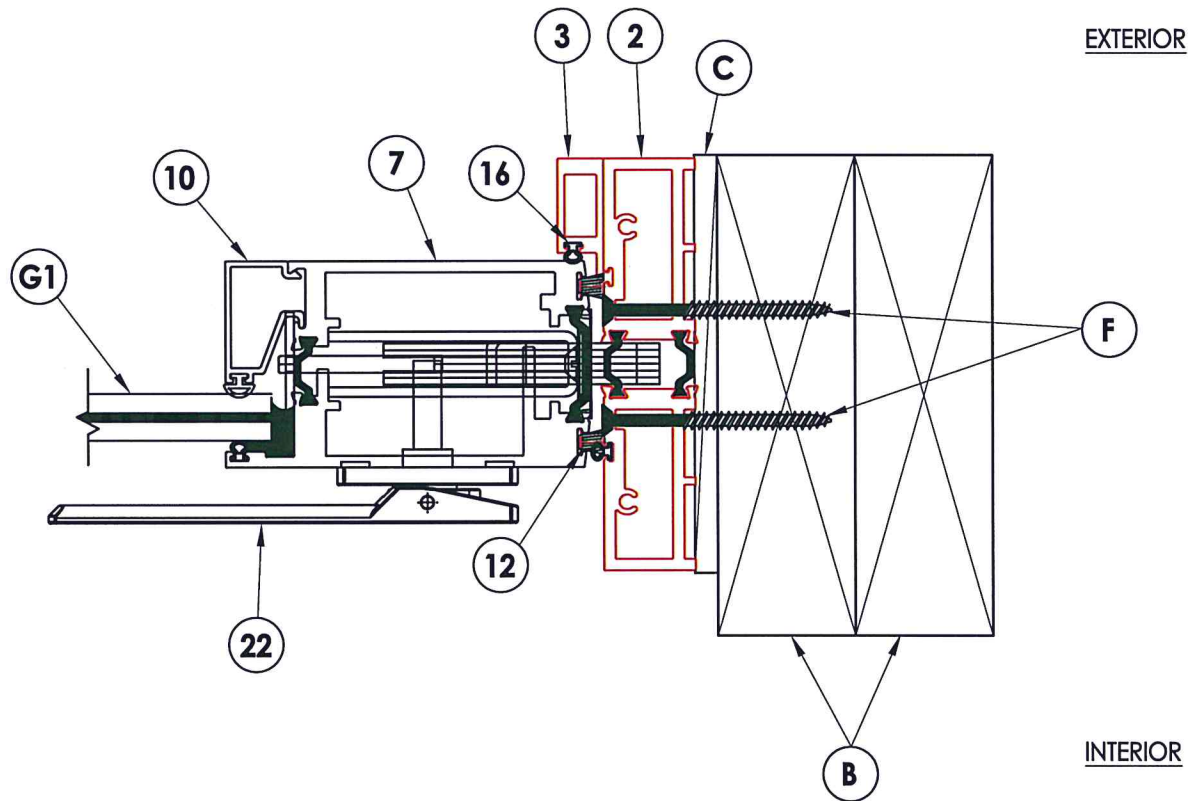

1
4 HORIZONTAL CROSS SECTION

PRODUCT: **FLEETWOOD**
SPEC. 5, 5a, 5b, 5c

PART OR ASSEMBLY:
HORIZONTAL CROSS SECTION

NO.	DATE	REVISIONS	BY

RW BUILDING
CONSULTANTS, INC.
813.659.9197

DATE: 11/04/21
SCALE: N.T.S.
DWG. BY: LFS
CHK. BY: RW
DRAWING NO.: L-9495
SHEET 4 OF 10

Testing Evaluation Laboratories Inc.
Specimen Complies with Drawing
Deviations Noted - TEL# 01993413
Date 12/14/2021 Verified by VKW

EXTERIOR

INTERIOR

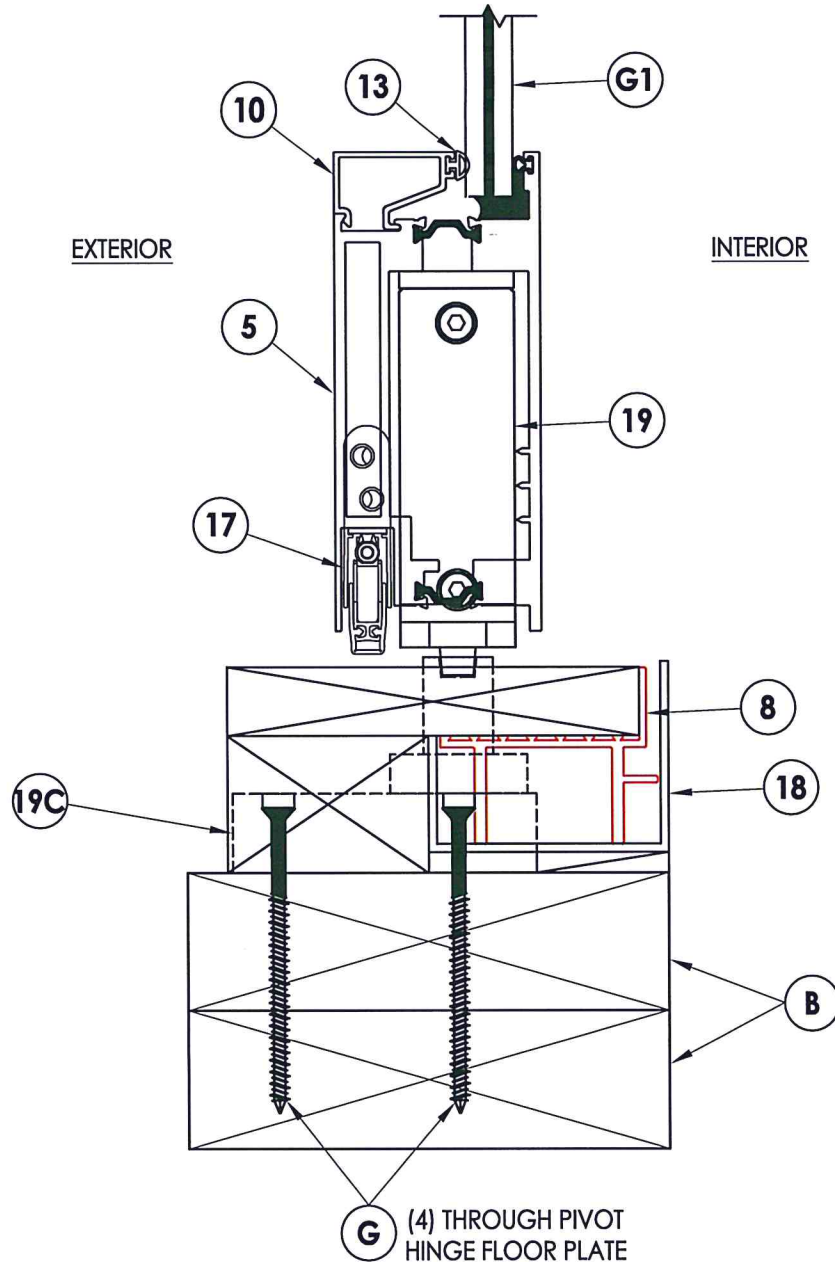

1
6 **VERTICAL CROSS SECTION**

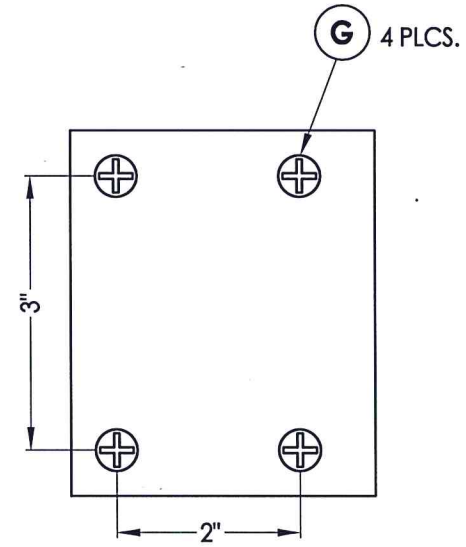

PIVOT HINGE FLOOR PLATE PLAN VIEW

Testing Evaluation Laboratories Inc.
 Specimen Complies with Drawing
 Deviations Noted - TEL# 01993413
 Date 12/14/2021 Verified by VKW

PRODUCT:		FLEETWOOD SPEC. 5, 5a, 5b, 5c	
PART OR ASSEMBLY:		VERTICAL CROSS SECTION	
NO.	DATE	REVISIONS	BY
 RW BUILDING CONSULTANTS, INC. 813.659.9197			
DATE: 11/04/21			
SCALE: N.T.S.			
DWG. BY: LFS			
CHK. BY: RW			
DRAWING NO.: L-9495			
SHEET 6 OF 10			

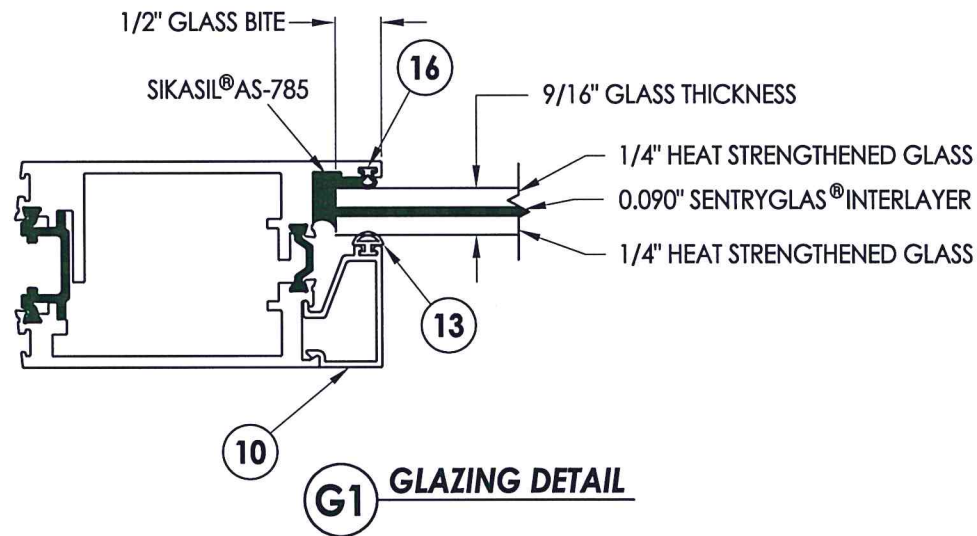

PRODUCT:		FLEETWOOD SPEC. 5, 5a, 5b, 5c	
PART OR ASSEMBLY:		GLAZING DETAILS	
NO.	DATE	REVISIONS	BY

RW BUILDING
CONSULTANTS, INC.
813.659.9197

DATE:	11/04/21
SCALE:	N.T.S.
DWG. BY:	LFS
CHK. BY:	RW
DRAWING NO.:	L-9495
SHEET	8 OF 10

Testing Evaluation Laboratories Inc.
Specimen Complies with Drawing
Deviations Noted - TEL# 01993413
Date 12/14/2021 Verified by VKW

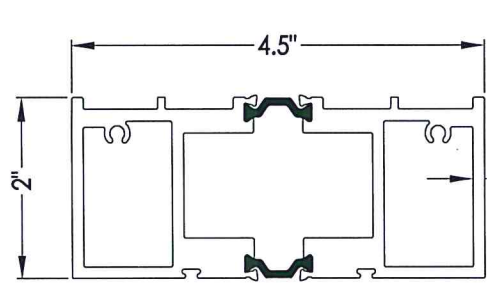

1 HEAD

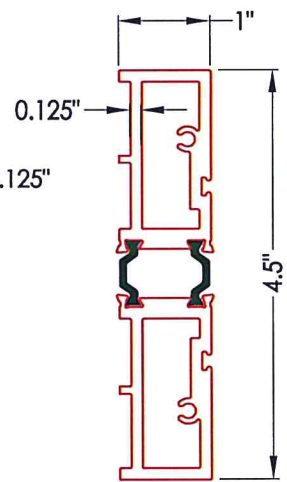

2 JAMB

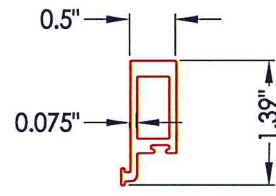

3 PANEL STOP

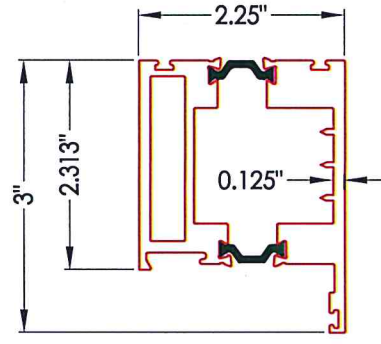

4 TOP RAIL

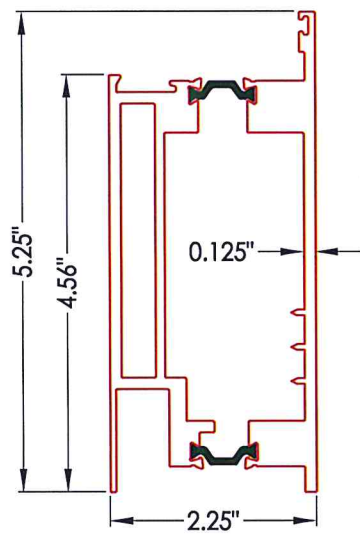

5 BOTTOM RAIL

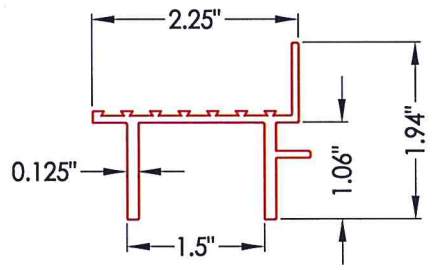

8 SUB SILL

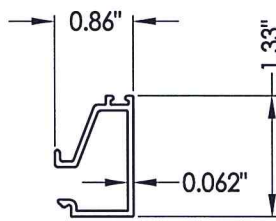

10 GLASS STOP 9/16"

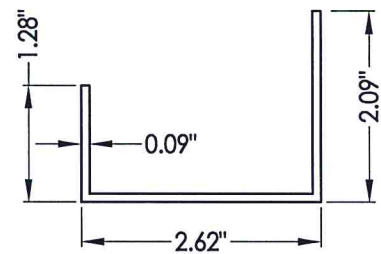

18 SILL PAN

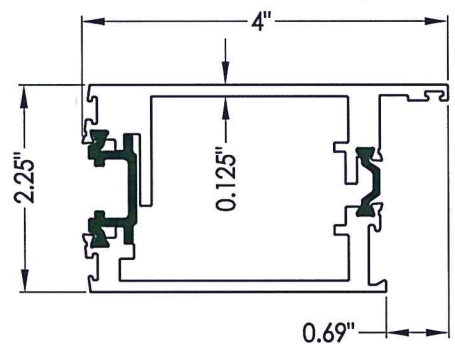

6 MULTI-POINT LOCK STILE

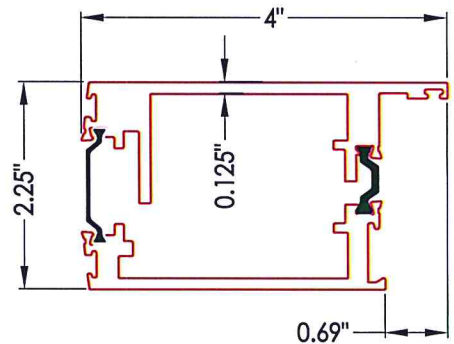

7 ARCHETYPE LOCK STILE

Testing Evaluation Laboratories Inc.
 Specimen Complies with Drawing
 Deviations Noted - TEL# 01993413
 Date 12/14/2021 Verified by VKW

PRODUCT:		FLEETWOOD SPEC. 5, 5a, 5b, 5c	
PART OR ASSEMBLY:		COMPONENTS	
NO.	DATE	REVISIONS	BY
 RW BUILDING CONSULTANTS, INC. 813.659.9197			
DATE: 11/04/21			
SCALE: N.T.S.			
DWG. BY: LFS			
CHK. BY: RW			
DRAWING NO.: L-9495			
SHEET 9 OF 10			

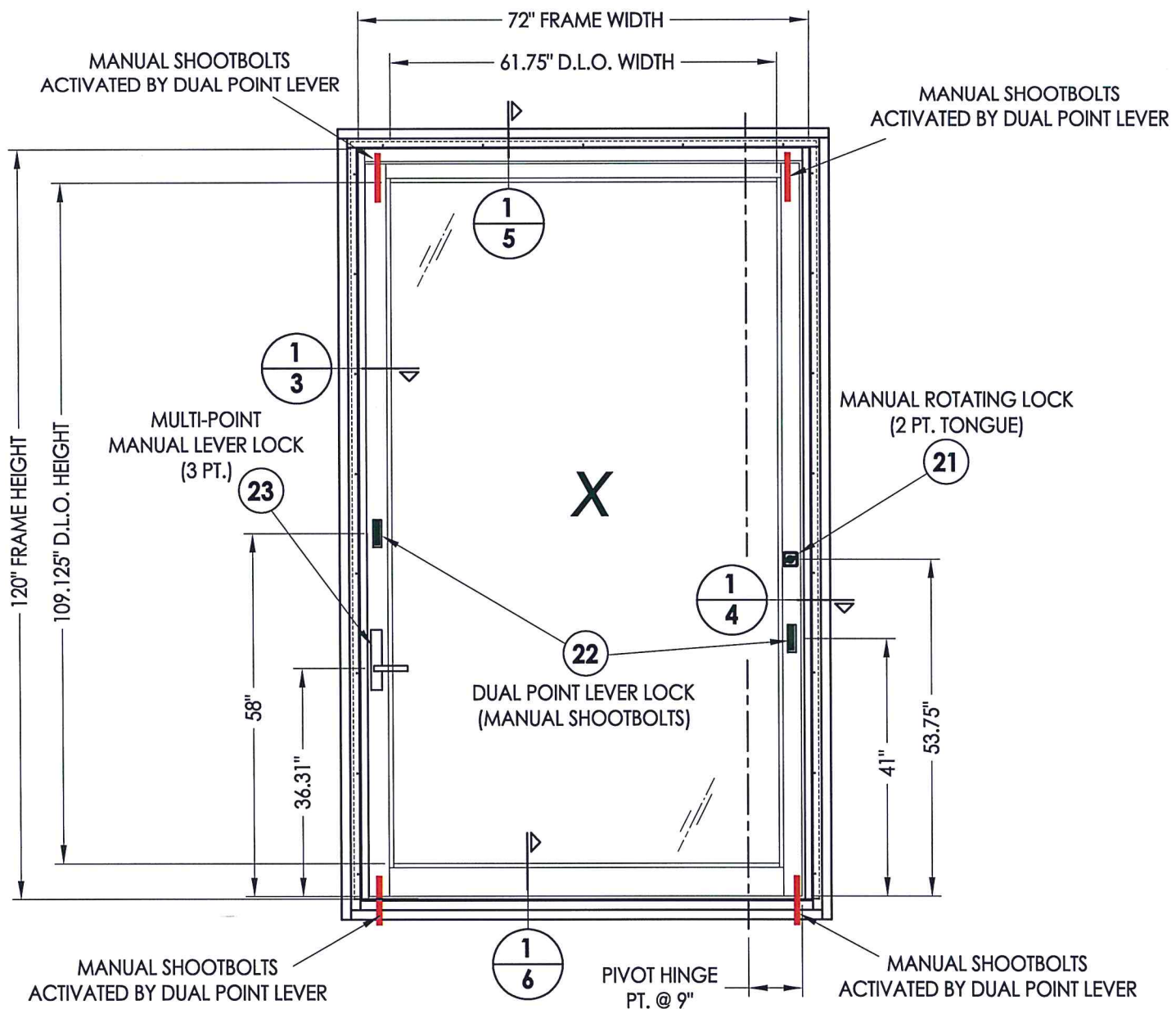

INTERIOR VIEW

Testing Evaluation Laboratories Inc.
 Specimen Complies with Drawing
 Deviations Noted - TEL# 01993413
 Date 12/14/2021 Verified by VKW

PRODUCT: FLEETWOOD SPEC. 6, 6a		PART OR ASSEMBLY: TEST ELEVATION	
NO.	DATE	REVISIONS	BY
 RW BUILDING CONSULTANTS, INC. 813.659.9197			
DATE: 11/04/21			
SCALE: N.T.S.			
DWG. BY: LFS			
CHK. BY: RW			
DRAWING NO.: L-9496			
SHEET 2 OF 10			

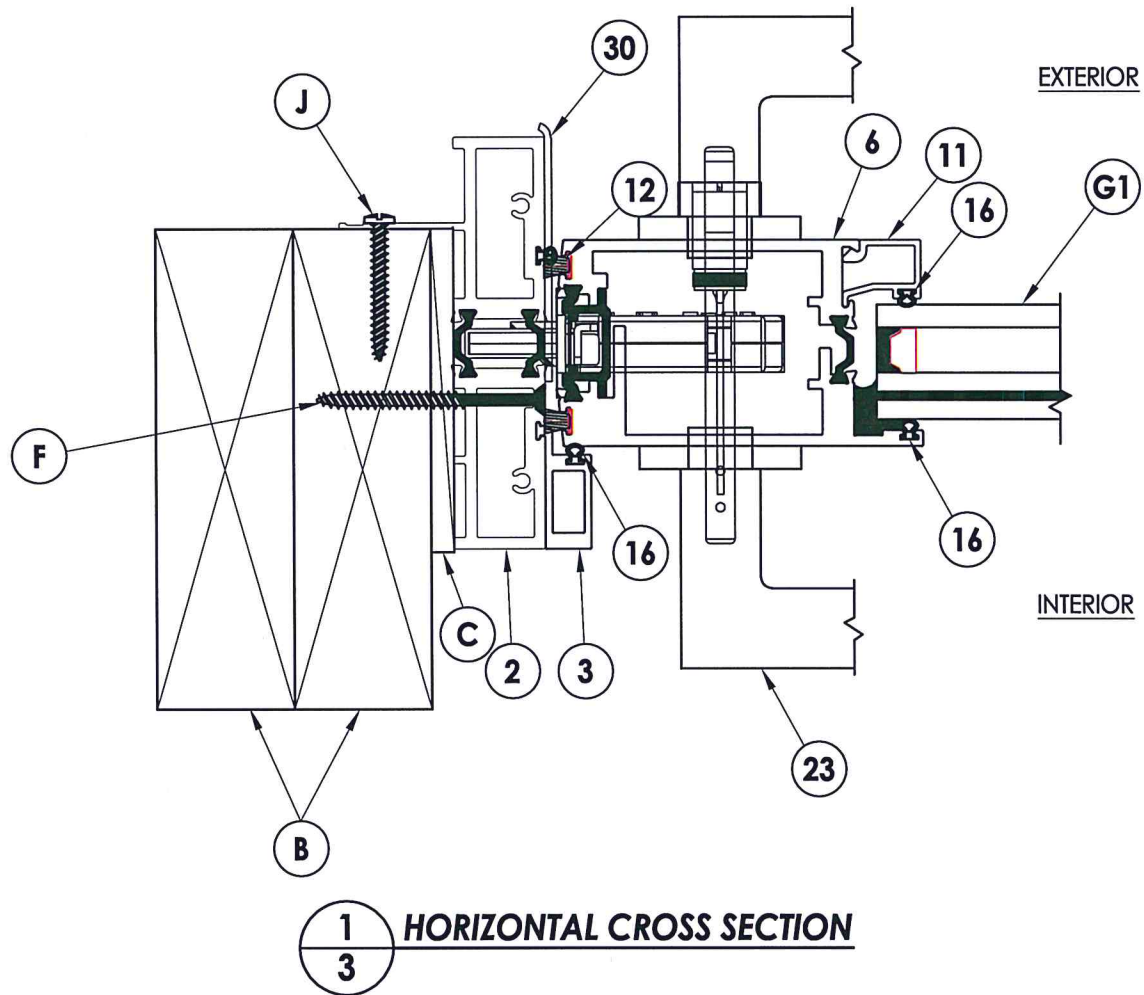

PRODUCT: FLEETWOOD SPEC. 6, 6a
 PART OR ASSEMBLY: HORIZONTAL CROSS SECTION

NO.	DATE	BY	REVISIONS

RW BUILDING CONSULTANTS, INC.
 813.659.9197

DATE: 11/04/21
 SCALE: N.T.S.
 DWG. BY: LFS
 CHK. BY: RW
 DRAWING NO.: L-9496
 SHEET 3 OF 10

Testing Evaluation Laboratories Inc.
 Specimen Complies with Drawing
 Deviations Noted - TEL# 01993413
 Date 12/14/2021 Verified by VKW

© 2021 R.W. BUILDING CONSULTANTS INC.

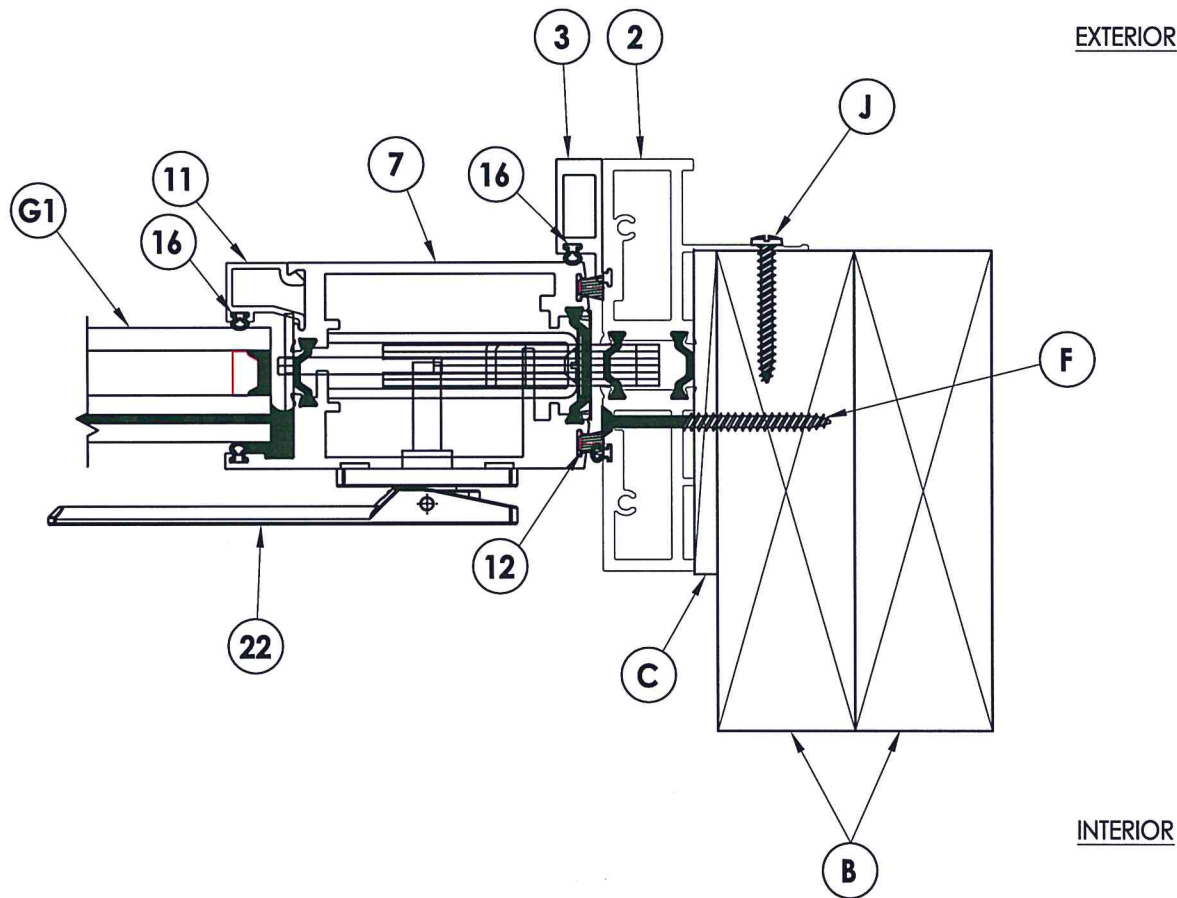

1
4 HORIZONTAL CROSS SECTION

EXTERIOR

INTERIOR

PRODUCT: FLEETWOOD SPEC. 6, 6a

PART OR ASSEMBLY: HORIZONTAL CROSS SECTION

NO.	DATE	BY	REVISIONS

RW BUILDING CONSULTANTS, INC.
813.659.9197

DATE: 11/04/21

SCALE: N.T.S.

DWG. BY: LFS

CHK. BY: RW

DRAWING NO.: L-9496

SHEET 4 OF 10

Testing Evaluation Laboratories Inc.
Specimen Complies with Drawing
Deviations Noted - TEL# 01993413
Date 12/14/2021 Verified by VKW

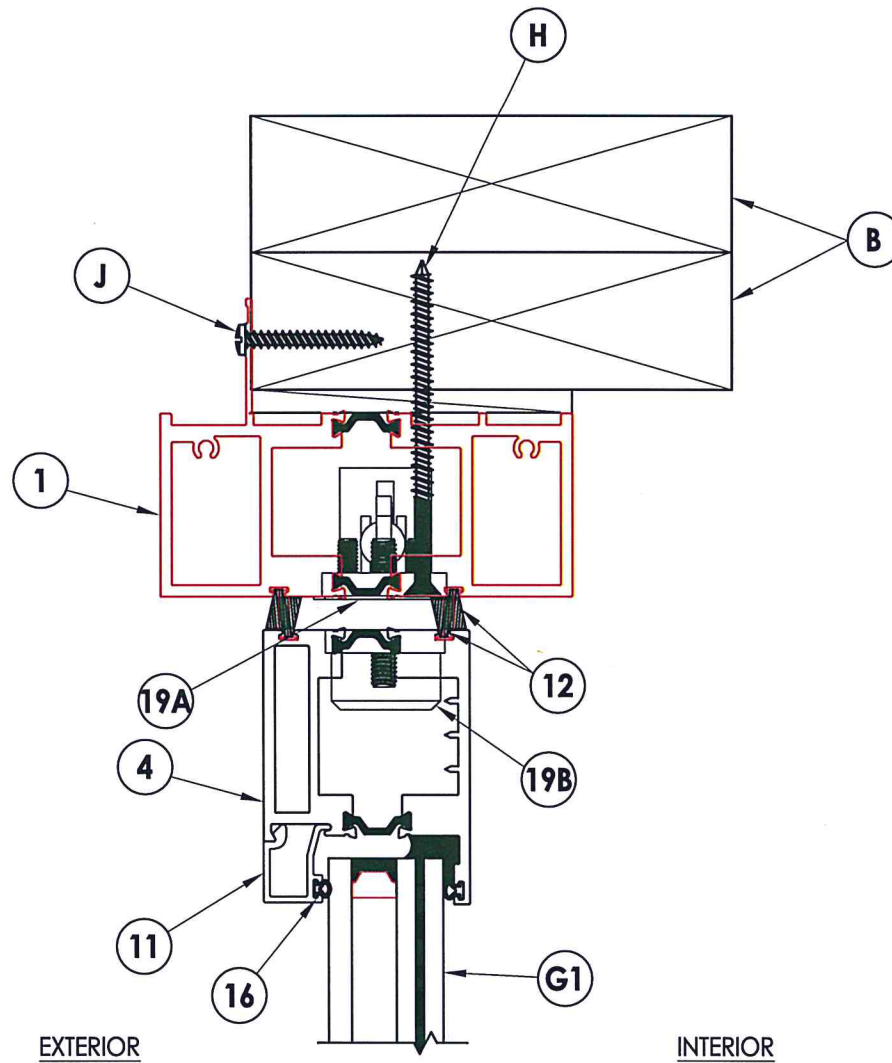

1
5 **VERTICAL CROSS SECTION**

Testing Evaluation Laboratories Inc.
 Specimen Complies with Drawing
 Deviations Noted - TEL# 01993413
 Date 12/14/2021 Verified by VKW

PRODUCT: FLEETWOOD SPEC. 6, 6a		PART OR ASSEMBLY: VERTICAL CROSS SECTION	
		NO.	DATE
		BY	REVISIONS
DATE: 11/04/21			
SCALE: N.T.S.			
DWG. BY: LFS			
CHK. BY: RW			
DRAWING NO.: L-9496			
SHEET 5 OF 10			

© 2021 R.W. BUILDING CONSULTANTS INC.

EXTERIOR

INTERIOR

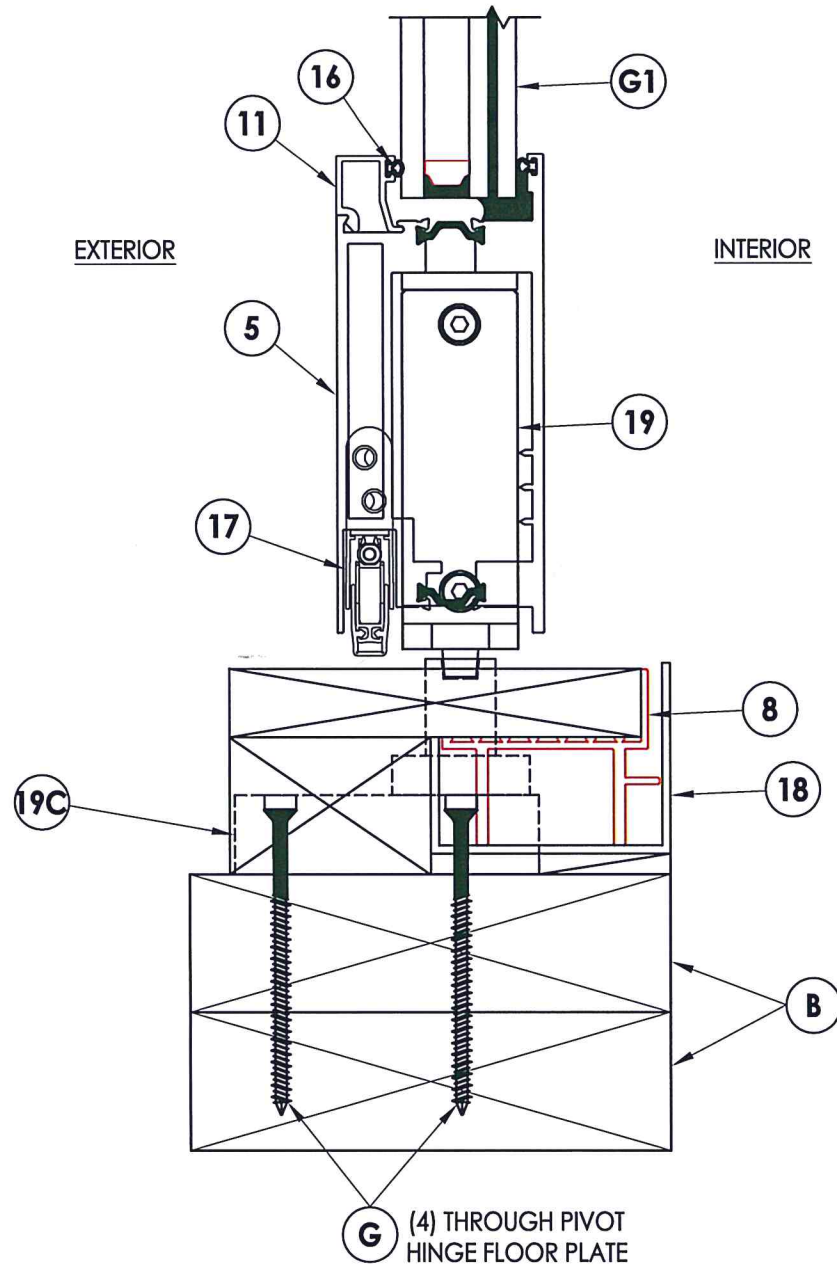

1
6 **VERTICAL CROSS SECTION**

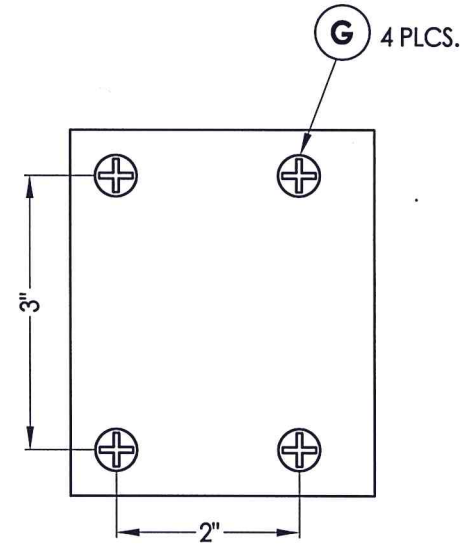

PIVOT HINGE FLOOR PLATE PLAN VIEW

Testing Evaluation Laboratories Inc.
 Specimen Complies with Drawing
 Deviations Noted - TEL# 01993413
 Date 12/14/2021 Verified by VKW

PRODUCT:		FLEETWOOD SPEC. 6, 6a	
PART OR ASSEMBLY:		VERTICAL CROSS SECTION	
NO.	DATE	BY	REVISIONS
 RW BUILDING CONSULTANTS, INC. 813.659.9197			
DATE: 11/04/21			
SCALE: N.T.S.			
DWG. BY: LFS			
CHK. BY: RW			
DRAWING NO.:			
L-9496			
SHEET 6 OF 10			

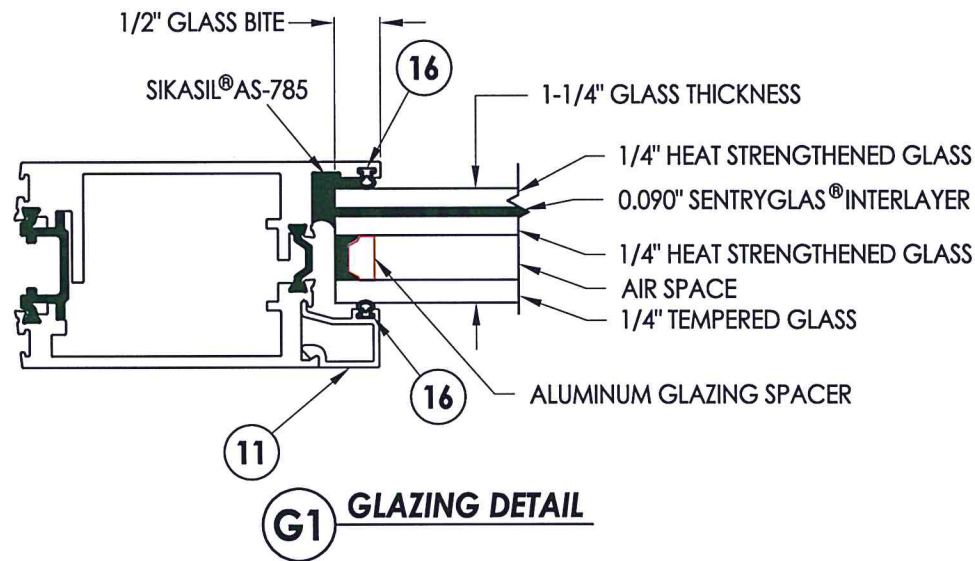

PRODUCT:		FLEETWOOD SPEC. 6, 6a	
PART OR ASSEMBLY:		GLAZING DETAILS	
NO.	DATE	BY	REVISIONS

RW BUILDING
CONSULTANTS, INC.
813.659.9197

DATE:	11/04/21
SCALE:	N.T.S.
DWG. BY:	LFS
CHK. BY:	RW
DRAWING NO.:	L-9496
SHEET	8 OF 10

Testing Evaluation Laboratories Inc.
Specimen Complies with Drawing
Deviations Noted - TEL# 01993413
Date 12/14/2021 Verified by VKW

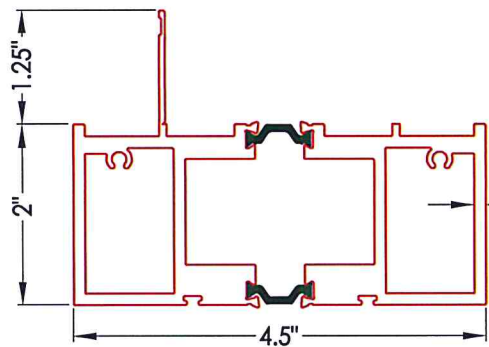

1 HEAD

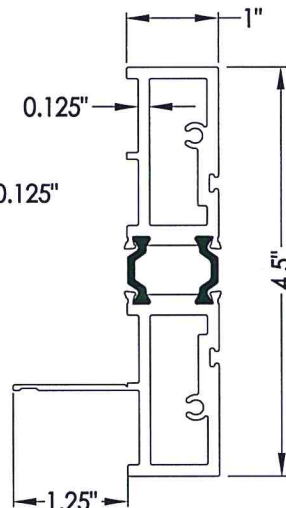

2 JAMB

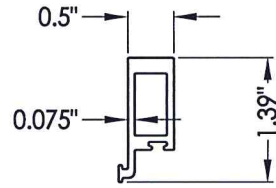

3 PANEL STOP

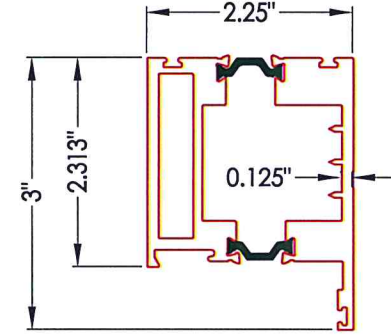

4 TOP RAIL

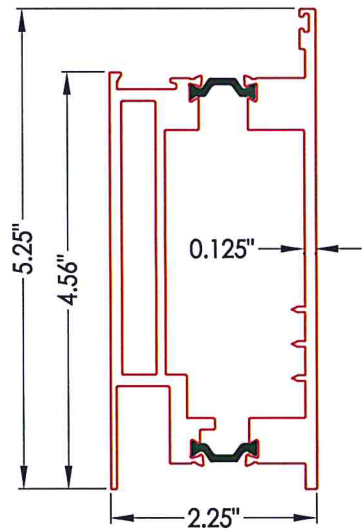

5 BOTTOM RAIL

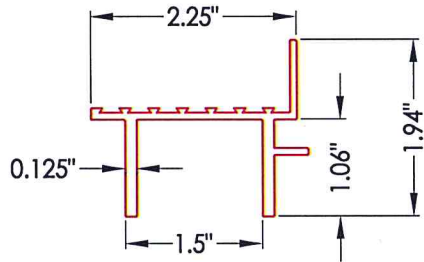

8 SUB SILL

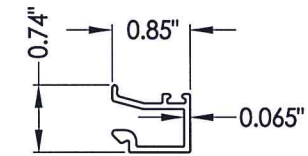

11 GLASS STOP 1-1/4"

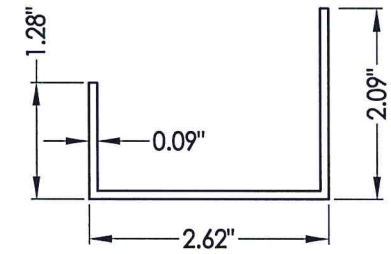

18 SILL PAN

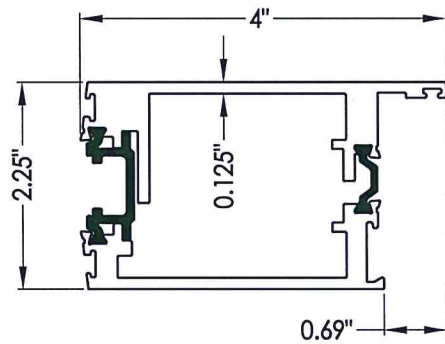

6 MULTI-POINT LOCK STILE

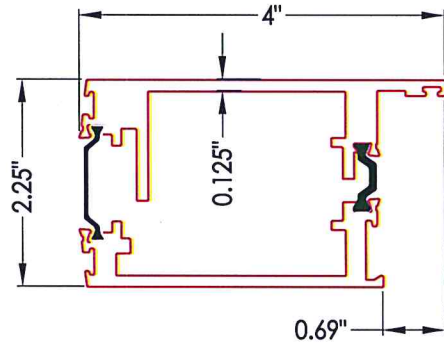

7 ARCHETYPE LOCK STILE

Testing Evaluation Laboratories Inc.
 Specimen Complies with Drawing
 Deviations Noted - TEL# 01993413
 Date 12/14/2021 Verified by VKW

PRODUCT:		FLEETWOOD SPEC. 6, 6a	
PART OR ASSEMBLY:		COMPONENTS	
NO.	DATE	BY	REVISIONS
DATE: 11/04/21			
SCALE: N.T.S.			
DWG. BY: LFS			
CHK. BY: RW			
DRAWING NO.: L-9496			
SHEET 9 OF 10			

BILL OF MATERIALS

M	DESCRIPTION	MATERIAL
B	2X TEST BUCK (SG >= 0.55)	WOOD
C	1/4" MAX. SHIM SPACE	-
F	#10 X 2-1/2" PFH WOOD SCREW	STEEL
G	1/4" Ø X 3-1/4" PFH ITW BUILDDEX CONCRETE SCREW	STEEL
H	#10 X 3-1/2" PFH WOOD SCREW	STEEL
J	#8 X 1-1/2" PPH SMS	STEEL
1	HEAD	6063-T6 ALUM
2	JAMB	6063-T6 ALUM
3	PANEL STOP	6063-T6 ALUM
4	TOP RAIL	6063-T6 ALUM
5	BOTTOM RAIL	6063-T6 ALUM
6	MULTI-POINT LOCK STILE	6063-T6 ALUM
7	ARCHETYPE LOCK STILE	6063-T6 ALUM
8	SUB SILL	6063-T6 ALUM
11	GLASS STOP (1-1/4")	6063-T6 ALUM
12	FIN SEAL MOHAIR - AMESBURY	MOHAIR
16	MINI BULB VINYL (EPDM 70 DUROMETER) - TREMCO	VINYL
17	DROP DOWN SEAL	-
18	SILL PAN	-
19	FRITSJURGENS SYSTEM M PIVOT HINGE	-
19A	PIVOT HINGE CEILING PLATE	-
19B	PIVOT HINGE TOP PIVOT	-
19C	PIVOT HINGE FLOOR PLATE	-
21	MANUAL ROTATING LOCK (2 PT. TONGUE)	-
22	DUAL POINT LEVER ACTIVATED MANUAL LOCK (2 PT. SHOOTBOLTS)	-
23	MULTI-POINT MANUAL LEVER LOCK (3 PT.)	-
25	#8 X 2-1/2" PFH WOOD SCREW	STEEL
26	#8 X 1/2" PFH SMS	STEEL
27	#8 X 1" PFH SMS	STEEL
30	LEVER LOCK LATCH & DEADBOLT STRIKE PLATE	STEEL
31	LEVER LOCK TONGUE STRIKE PLATE	STEEL
33	ROTATING LOCK TONGUE STRIKE PLATE	STEEL
34	DUAL POINT SHOOTBOLT STRIKE PLATE	STEEL

PRODUCT:	FLEETWOOD SPEC. 6, 6a		
	PART OR ASSEMBLY: BILL OF MATERIALS		
NO.	DATE	BY	REVISIONS



DATE: 11/04/21
 SCALE: N.T.S.
 DWG. BY: LFS
 CHK. BY: RW
 DRAWING NO.: L-9496
 SHEET 10 OF 10

Testing Evaluation Laboratories Inc.
 Specimen Complies with Drawing
 Deviations Noted - TEL# 01993413
 Date 12/14/2021 Verified by VKW