



Testing Evaluation Laboratories, Inc.

2002 Wood Court Suite 1 – Plant City, FL 33563
 Phone: 813-754-9887

AAMA/WDMA/CSA 101/I.S.2/A440-08 Canadian Supplement A440S1-09

TEST REPORT SUMMARY

Test Report Issued To:

FLEETWOOD WINDOWS AND DOORS
 1 Fleetwood Way
 Corona, CA 92879

KONA 3800 Impact Resistant Aluminum Casement Windows

Title	Summary of Results		
	Specimen 1 (4 hinges)	Specimen 1E (5 hinges)	Specimen 2
Primary Product Designator	Class LC- PG65 1067 x 2135 (42 x 84) Type C	Class LC- PG65 1067 x 2135 (42 x 84) Type C	Class LC- PG65 1067 x 2135 (42 x 84) Type C
Design Pressure	+3112/-3112 Pa (+65.0/- 65.0 psf)	+3112/-4070 Pa (+65.0/- 85.0 psf)	+3112/-4070 Pa (+65.0/- 85.0 psf)
Operating Force	Pass	Pass	Pass
Air Infiltration	0.325 L/s/m ² (0.065 scfm/ft ²)	See Specimen 1 for Results	See Specimen 1 for Results
Air Infiltration/Exfiltration (A440S1-09)	Level A3: < 0.50 L/s•m ²	See Specimen 1 for Results	See Specimen 1 for Results
Water Resistance	467 Pa (9.75 psf)	See Specimen 1 for Results	See Specimen 1 for Results
Structural Test Pressure	+4668/-4668 Pa (+97.5/- 97.5 psf)	+4668/-6105 Pa (+97.5/- 127.5 psf)	+4668/-6105 Pa (+97.5/- 127.5 psf)
Forced Entry	No Entry	No Entry	No Entry

Title	Summary of Results		
	Specimen 3	Specimen 4	Specimen 5
Primary Product Designator	Class LC- PG65 1067 x 1651 (42 x 65) Type C	Class LC- PG65 3175 x 2135 (125 x 84) Type C	Class LC- PG65 1067 x 2135 (42 x 84) Type C
Design Pressure	+3112/-4070 Pa (+65.0/- 85.0 psf)	+3112/-4070 Pa (+65.0/- 85.0 psf)	+3112/-3112 Pa (+65.0/- 65.0 psf)
Operating Force	Pass	Pass	Pass
Air Infiltration	See Specimen 1 for Results	0.090 L/s/m ² (0.018 scfm/ft ²)	See Specimen 1 for Results
Air Infiltration/Exfiltration (A440S1-09)	See Specimen 1 for Results	Level A3: < 0.50 L/s•m ²	See Specimen 1 for Results
Water Resistance	See Specimen 1 for Results	467 Pa (9.75 psf)	See Specimen 1 for Results
Structural Test Pressure	+4668/-6105 Pa (+97.5/- 127.5 psf)	+4668/-6105 Pa (+97.5/- 127.5 psf)	+4668/-4668 Pa (+97.5/- 97.5 psf)
Forced Entry	No Entry	No Entry	No Entry

Title	Summary of Results		
	Specimen 6	Specimen 7	Specimen 8
Primary Product Designator	Class LC- PG65 1067 x 2135 (42 x 84) Type C	Class LC- PG65 1067 x 4572 (42 x 180) Type AP	Class LC- PG65 1067 x 4572 (42 x 180) Type AP
Design Pressure	+3112/-3112 Pa (+65.0/- 65.0 psf)	+3112/-3112 Pa (+65.0/- 65.0 psf)	+3112/-3112 Pa (+65.0/- 65.0 psf)
Operating Force	Pass	Pass	Pass
Air Infiltration	See Specimen 1 for Results	0.070 L/s/m ² (0.014 scfm/ft ²)	0.105 L/s/m ² (0.021 scfm/ft ²)
Air Infiltration/Exfiltration (A440S1-09)	See Specimen 1 for Results	Level A3: < 0.50 L/s•m ²	Level A3: < 0.50 L/s•m ²
Water Resistance	See Specimen 1 for Results	467 Pa (9.75 psf)	467 Pa (9.75 psf)
Structural Test Pressure	+4668/-4668 Pa (+97.5/- 97.5 psf)	+4668/-4668 Pa (+97.5/- 97.5 psf)	+4668/-4668 Pa (+97.5/- 97.5 psf)
Forced Entry	No Entry	No Entry	No Entry

Title	Summary of Results
	Specimen 12
Primary Product Designator	Class LC- PG75 1067 x 1829 (42 x 72) Type C
Design Pressure	+3112/-3112 Pa (+65.0/- 65.0 psf)
Operating Force	Pass
Air Infiltration	See Specimen 1 for Results
Air Infiltration/Exfiltration (A440S1-09)	See Specimen 1 for Results
Water Resistance	See Specimen 1 for Results
Structural Test Pressure	+4668/-4668 Pa (+97.5/- 97.5 psf)
Forced Entry	No Entry

Reference should be made to Report No. TEL 01990817 for complete test specimen description and data. For corresponding data regarding ASTM E1886 and ASTM E1996 reference should be made to Report No. TEL 01990818.

For Testing Evaluation Laboratories, Inc.



Vivian K. Wright,
President



Testing Evaluation Laboratories, Inc.

2002 Wood Court Suite 1 – Plant City, FL 33563

Phone: 813-754-9887

AAMA/WDMA/CSA 101/I.S.2/A440-08

Canadian Supplement A440S1-09

Issued to:

FLEETWOOD WINDOWS AND DOORS

1 Fleetwood Way

Corona, CA 92879

Report No: TEL 01990817

Test Dates: October 3-5, 2013

Report Date: October 31, 2013

IAS Lab Certification Number: TL-299

Project Summary: Testing Evaluation Laboratories, Inc. (TEL) was contracted by Fleetwood Windows and Doors to perform tests on the Kona 3800 Casement and Awning Windows at TEL's Plant City, FL test facility.

Please see individual specimen results for information regarding the Performance Grade successfully achieved by each specimen.

Test specimen descriptions and results are reported herein.

Test Specifications: The test specimens were evaluated in accordance with the following:

AAMA/WDMA/CSA 101/I.S.2/A440-08 and Canadian Supplement A440S1-09

Standard Specification for Windows, Doors and Unit Skylights

Test Specimen Description:

Series / Model: Kona 3800 Casement and Awning Windows

Type: Aluminum Casement and Awning Windows

Overall Size: 1067 mm x 2135 mm (42.00" x 84.00") – Specimens 1, 1e, 2, 5 and 6 – (X)
1067 mm x 1651 mm (42.00" x 65.00") – Specimen 3 – (X)
3175 mm x 2135 mm (125.00" x 84.00") - Specimen 4 – (XXX)
1067 mm x 4572 mm (42.00" x 180.00") – Specimen 7 - (X/O/X)
1067 mm x 4572 mm (42.00" x 180.00") – Specimen 8 - (O/X/O)
1067 mm x 1829 mm (42.00" x 72.00") – Specimen 12 – (X)

Daylight Opening: 840 mm x 1908 mm (33.063" x 75.13") – Specimens 1, 1e, 2, 5 and 6 – (X)
854 mm x 1435 mm (33.625" x 56.500") – Specimen 3 – (X)
835 mm x 1907 mm (32.88" x 75.06") - Specimen 4 – (XXX) – All panels
842 mm x 962 mm (33.13" x 37.875") – Specimen 7 - Top Active Panel (X)
992 mm x 2073 mm (39.062" x 81.625") – Specimen 7 - Center Fixed Panel (O)
842 mm x 1051 mm (33.13" x 41.375") – Specimen 7 - Bottom Active Panel (X)

Test Specimen Description: Continued

Daylight Opening: 992 mm x 237 mm (39.062" x 9.312") – Specimen 8 - Top Fixed Panel (O)
842 mm x 1932 mm (33.13" x 76.062") – Specimen 8 - Center Active Panel (X)
992 mm x 2073 mm (39.062" x 81.625") – Specimen 8 - Bottom Fixed Panel (O)
835 mm x 1424 mm (32.88" x 56.06") – Specimen 12 – (X)

Glazing Detail: See attached drawing numbers L-7031, L-7032, L-7032A and L-7033
For glazing details.

Frame Material: Aluminum

Finish: Mill Finish

For Tested Elevation, Vertical Cross Sections, Horizontal Cross Sections, Components, Frame Anchoring, Glazing Detail and Bill of Materials See Attached Drawing numbers L-7031, L-7032, L-7032A and L-7033.

Test Results: Specimen 1 – Class LC-PG65 1067 x 2134 (42 x 84) Type C - Aluminum Casement Window (X)
(Tested with four hinges)

The test results are tabulated as follows:

<u>Paragraph</u>	<u>Title of Test – Test Method</u>	<u>Results</u>	<u>Allowed</u>
5.3.1	Operating Force per ASTM E2068-00		
	Initiate Motion	18 N (4.1 lbf)	Report Only
	Maintain Motion	13 N (3.0 lbf)	45 N (10.00 lbf)
	Latches	53 N (12.0 lbf)	100 N (22.5 lbf)
5.3.2.1	Air Infiltration per ASTM E283 @ 75 Pa (1.57 psf)	0.325 L/s/m ² (0.065 SCFM/FT ²)	1.5 L/s/m ² (0.30 SCFM/FT ²)
	Air Infiltration per ASTM E283 @ 299 Pa (6.24 psf)	0.790 L/s/m ² (0.158 SCFM/FT ²)	1.5 L/s/m ² (0.30 SCFM/FT ²)
	Air Exfiltration per ASTM E283 @ 75 Pa (1.57 psf)	0.100 L/s/m ² (0.020 SCFM/FT ²)	1.5 L/s/m ² (0.30 SCFM/FT ²)
	Air Exfiltration per ASTM E283 @ 299 Pa (6.24 psf)	0.820 L/s/m ² (0.164 SCFM/FT ²)	1.5 L/s/m ² (0.30 SCFM/FT ²)
Note #1:	<i>The tested specimen meets (or exceeds) the performance levels specified in AAMA/WDMA/CSA 101/I.S.2/A440-08 (A440S1-09) for air infiltration/exfiltration.</i>		
5.3.3.2	Water Resistance per ASTM E547		See Note #2
5.3.4.2	Uniform Load Structural per ASTM E330		See Note #2
Note #2:	<i>The client opted to start at a pressure higher than the minimum required. Those results are listed under "Optional Performance".</i>		
5.3.5	Forced Entry resistance per ASTM F588 Type B Grade 10		
	Disassembly Test	No Entry	No Entry
	Test B1 – B3	No Entry	No Entry
	Sash/Panel Manipulation Test	No Entry	No Entry
	Lock Manipulation Test	No Entry	No Entry
5.3.6.4.3	Sash Vertical Deflection Test 270N (60 lbf)	(10.693 mm (0.421"))	20.3 mm (0.80") Max
5.3.6.6.2	Distributed Load Test 300 Pa (6.2 psf)	No Damage	No Damage
Optional Performance			
4.3.2.1	Water Resistance per ASTM E547 (without insect screen) 467 Pa (9.75 psf)	No Leakage	No Leakage

Specimen 1: Optional Performance – Continued

4.4.2.6 Optional Performance

Range	Time (seconds)	Load Pa (psf)	Location	Deflection mm (in.)	Allowable mm (in.)
Half Test Positive	30	1556 (32.50)			
Test Positive	30	3112 (65.00)	1	0.584 (0.023)	See Note #3
Half Test Negative	30	1556 (32.50)			
Test Negative	30	3112 (65.00)	1	0.711 (0.028)	See Note #3

Note #3: *The deflections reported are not limited by AAMA/WDMA/CSA 101/I.S.2/A440-08 (A440S1-09) for this product designation. The deflection data is recorded in this report for special code compliance and information only. See Note #4 for deflection locations.*

Range	Time (seconds)	Load Pa (psf)	Location	Deflection mm(in.)	Set mm(in.)	Allowable mm(in.)
Half Proof Positive	10	2334 (48.75)				
Proof Positive	30	4668 (97.50)	1	0.813 (0.032)	0.254 (0.010)	3.810 (0.150)
Half Proof Negative	10	2334 (48.75)				
Proof Negative	30	4668 (97.50)	1	0.838 (0.033)	0.102 (0.004)	3.810 (0.150)

Note #4: *Deflection/Set for Location 1 measured at center of top rail.*

Test Results: Specimen 1E – Class LC-PG65 1067 x 2134 (42 x 84) Type C - Aluminum Casement Window
(Tested with Five Hinges)

The test results are tabulated as follows:

<u>Paragraph</u>	<u>Title of Test – Test Method</u>	<u>Results</u>	<u>Allowed</u>
5.3.1	Operating Force per ASTM E2068-00	**	
5.3.2.1	Air Infiltration per ASTM E283	**	
Note #1:	<i>The tested specimen meets (or exceeds) the performance levels specified in AAMA/WDMA/CSA 101/I.S.2/A440-08 (A440S1-09) for air infiltration/exfiltration.</i>		
5.3.3.2	Water Resistance per ASTM E547		See Note #2
5.3.4.2	Uniform Load Structural per ASTM E330		See Note #2
Note #2:	<i>The client opted to start at a pressure higher than the minimum required. Those results are listed under "Optional Performance".</i>		
5.3.5	Forced Entry resistance per ASTM F588	**	
5.3.6.4.3	Sash Vertical Deflection Test	**	
5.3.6.6.2	Distributed Load Test	**	

Optional Performance

4.3.2.1	Water Resistance per ASTM E547	**	
---------	--------------------------------	----	--

**** Please see Specimen 1 of this report for these test results.**

4.4.2.6 Optional Performance

Range	Time (seconds)	Load Pa (psf)	Location	Deflection mm (in.)	Allowable mm (in.)
Half Test Positive	10	1556 (32.50)			
Test Positive	10	3112 (65.00)	1	0.660 (0.026)	See Note #3
Half Test Negative	10	2035 (42.50)			
Test Negative	10	4070 (85.00)	1	1.041 (0.041)	See Note #3

Note #3: *The deflections reported are not limited by AAMA/WDMA/CSA 101/I.S.2/A440-08 (A440S1-09) for this product designation. The deflection data is recorded in this report for special code compliance and information only. See Note #4 for deflection locations.*

Specimen 1E: Optional Performance – Continued

Range	Time (seconds)	Load Pa (psf)	Location	Deflection mm (in.)	Set mm (in.)	Allowable mm (in.)
Half Proof Positive	10	2334 (48.75)				
Proof Positive	10	4668 (97.50)	1	0.914 (0.036)	0.179 (0.011)	3.810 (0.150)
Half Proof Negative	10	3052 (63.75)				
Proof Negative	10	6105 (127.50)	1	2.413 (0.095)	0.051 (0.002)	3.810 (0.150)

Note #4: Deflection/Set for Location 1 measured at center of top rail.

Test Results: Specimen 2 – Class LC-PG65 1067 x 2134 (42 x 84) Type C - Aluminum Casement Window
(Tested with Five Hinges)

The test results are tabulated as follows:

<u>Paragraph</u>	<u>Title of Test – Test Method</u>	<u>Results</u>	<u>Allowed</u>
5.3.1	Operating Force per ASTM E2068-00	**	
5.3.2.1	Air Infiltration per ASTM E283	**	
Note #1:	<i>The tested specimen meets (or exceeds) the performance levels specified in AAMA/WDMA/CSA 101/I.S.2/A440-08 (A440S1-09) for air infiltration/exfiltration.</i>		
5.3.3.2	Water Resistance per ASTM E547		See Note #2
5.3.4.2	Uniform Load Structural per ASTM E330		See Note #2
Note #2:	<i>The client opted to start at a pressure higher than the minimum required. Those results are listed under "Optional Performance".</i>		
5.3.5	Forced Entry resistance per ASTM F588	**	
5.3.6.4.3	Sash Vertical Deflection Test	**	
5.3.6.6.2	Distributed Load Test	**	

Optional Performance

4.3.2.1	Water Resistance per ASTM E547	**	
---------	--------------------------------	----	--

**** Please see Specimen 1 of this report for these test results.**

4.4.2.6 Optional Performance

Range	Time (seconds)	Load Pa (psf)	Location	Deflection mm (in.)	Allowable mm (in.)
Half Test Positive	10	1556 (32.50)			
Test Positive	10	3112 (65.00)	1	0.940 (0.037)	See Note #3
Half Test Negative	10	2035 (42.50)			
Test Negative	10	4070 (85.00)	1	1.524 (0.060)	See Note #3

Note #3: *The deflections reported are not limited by AAMA/WDMA/CSA 101/I.S.2/A440-08 (A440S1-09) for this product designation. The deflection data is recorded in this report for special code compliance and information only. See Note #4 for deflection locations.*

Specimen 2: Optional Performance – Continued

Range	Time (seconds)	Load Pa (psf)	Location	Deflection mm (in.)	Set mm (in.)	Allowable mm (in.)
Half Proof Positive	10	2334 (48.75)				
Proof Positive	10	4668 (97.50)	1	0.940 (0.037)	0.051 (0.002)	3.810 (0.150)
Half Proof Negative	10	3052 (63.75)				
Proof Negative	10	6105 (127.50)	1	1.600 (0.063)	0.229 (0.009)	3.810 (0.150)

Note #4: Deflection/Set for Location 1 measured at center of top rail.

Test Results: Specimen 3 – Class LC-PG65 1067 x 1651 (42 x 65) Type C - Aluminum Casement Window

The test results are tabulated as follows:

<u>Paragraph</u>	<u>Title of Test – Test Method</u>	<u>Results</u>	<u>Allowed</u>
5.3.1	Operating Force per ASTM E2068-00	**	
5.3.2.1	Air Infiltration per ASTM E283	**	
Note #1:	<i>The tested specimen meets (or exceeds) the performance levels specified in AAMA/WDMA/CSA 101/I.S.2/A440-08 (A440S1-09) for air infiltration/exfiltration.</i>		
5.3.3.2	Water Resistance per ASTM E547		See Note #2
5.3.4.2	Uniform Load Structural per ASTM E330		See Note #2
Note #2:	<i>The client opted to start at a pressure higher than the minimum required. Those results are listed under "Optional Performance".</i>		
5.3.5	Forced Entry resistance per ASTM F588	**	
5.3.6.4.3	Sash Vertical Deflection Test	**	
5.3.6.6.2	Distributed Load Test	**	

Optional Performance

4.3.2.1	Water Resistance per ASTM E547	**
---------	--------------------------------	----

**** Please see Specimen 1 of this report for these test results.**

4.4.2.6 Optional Performance

Range	Time (seconds)	Load Pa (psf)	Location	Deflection mm (in.)	Allowable mm (in.)
Half Test Positive	10	1556 (32.50)			
Test Positive	10	3112 (65.00)	1	0.127 (0.005)	See Note #3
Half Test Negative	10	2035 (42.50)			
Test Negative	10	4070 (85.00)	1	0.381 (0.015)	See Note #3

Note #3: *The deflections reported are not limited by AAMA/WDMA/CSA 101/I.S.2/A440-08 (A440S1-09) for this product designation. The deflection data is recorded in this report for special code compliance and information only. See Note #4 for deflection locations.*

Specimen 3: Optional Performance – Continued

Range	Time (seconds)	Load Pa (psf)	Location	Deflection mm (in.)	Set mm (in.)	Allowable mm (in.)
Half Proof Positive	10	2334 (48.75)	1	0.483 (0.019)	0.127 (0.005)	3.810 (0.150)
Proof Positive	10	4668 (97.50)				
Half Proof Negative	10	3052 (63.75)	1	0.686 (0.027)	0.203 (0.008)	3.810 (0.150)
Proof Negative	10	6105 (127.50)				

Note #4: Deflection/Set for Location 1 measured at center of top rail.

Test Results: Specimen 4 – Class LC-PG65 3175 x 2134 (125 x 84) Type C – Muller Aluminum Casement Window (XXX)

The test results are tabulated as follows:

<u>Paragraph</u>	<u>Title of Test – Test Method</u>	<u>Results</u>	<u>Allowed</u>
5.3.1	Operating Force per ASTM E2068-00	**	
5.3.2.1	Air Infiltration per ASTM E283 @ 75 Pa (1.57 psf)	0.090 L/s/m ² (0.018 SCFM/FT ²)	1.5 L/s/m ² (0.30 SCFM/FT ²)
	Air Infiltration per ASTM E283 @ 299 Pa (6.24 psf)	0.175 L/s/m ² (0.035 SCFM/FT ²)	1.5 L/s/m ² (0.30 SCFM/FT ²)
	Air Exfiltration per ASTM E283 @ 75 Pa (1.57 psf)	0.065 L/s/m ² (0.013 SCFM/FT ²)	1.5 L/s/m ² (0.30 SCFM/FT ²)
	Air Exfiltration per ASTM E283 @ 299 Pa (6.24 psf)	0.100 L/s/m ² (0.020 SCFM/FT ²)	1.5 L/s/m ² (0.30 SCFM/FT ²)
Note #1:	<i>The tested specimen meets (or exceeds) the performance levels specified in AAMA/WDMA/CSA 101/I.S.2/A440-08 (A440S1-09) for air infiltration/exfiltration.</i>		
5.3.3.2	Water Resistance per ASTM E547		See Note #2
5.3.4.2	Uniform Load Structural per ASTM E330		See Note #2
Note #2:	<i>The client opted to start at a pressure higher than the minimum required. Those results are listed under "Optional Performance".</i>		
Optional Performance			
4.3.2.1	Water Resistance per ASTM E547 (without insect screen) 467 Pa (9.75 psf)	No Leakage	No Leakage
5.3.5	Forced Entry resistance per ASTM F588	**	
5.3.6.4.3	Sash Vertical Deflection Test	**	
5.3.6.6.2	Distributed Load Test	**	

**** Please see Specimen 1 of this report for these test results.**

Specimen 4: Optional Performance – Continued

4.4.2.6 Optional Performance

Range	Time (seconds)	Load Pa (psf)	Location	Deflection mm (in.)	Allowable mm (in.)
Half Test Positive	30	1556 (32.50)			
Test Positive	30	3112 (65.00)	1	4.445 (0.175)	See Note #3
Half Test Negative	30	2035 (42.50)			
Test Negative	30	4070 (85.00)	1	5.232 (0.206)	See Note #3

Note #3: *The deflections reported are not limited by AAMA/WDMA/CSA 101/I.S.2/A440-08 (A440S1-09) for this product designation. The deflection data is recorded in this report for special code compliance and information only. See Note #4 for deflection locations.*

Range	Time (seconds)	Load Pa (psf)	Location	Deflection mm(in.)	Set mm(in.)	Allowable mm(in.)
Half Proof Positive	10	2334 (48.75)				
Proof Positive	30	4668 (97.50)	1	6.172 (0.243)	0.127 (0.005)	8.230 (0.324)
Half Proof Negative	10	3053 (63.75)				
Proof Negative	30	6105 (127.50)	1	7.061 (0.278)	0.406 (0.016)	8.230 (0.324)

Note #4: *Deflection/Set for Location 1 measured at center of top rail.*

Test Results: Specimen 5 – Class LC-PG65 1067 x 2134 (42 x 84) Type C – Aluminum Casement Window (X)

The test results are tabulated as follows:

<u>Paragraph</u>	<u>Title of Test – Test Method</u>	<u>Results</u>	<u>Allowed</u>
5.3.1	Operating Force per ASTM E2068-00	**	
5.3.2.1	Air Infiltration per ASTM E283 @ 75 Pa (1.57 psf)	**	
	Air Infiltration per ASTM E283 @ 299 Pa (6.24 psf)	**	
	Air Exfiltration per ASTM E283 @ 75 Pa (1.57 psf)	**	
	Air Exfiltration per ASTM E283 @ 299 Pa (6.24 psf)	**	
Note #1:	<i>The tested specimen meets (or exceeds) the performance levels specified in AAMA/WDMA/CSA 101/I.S.2/A440-08 (A440S1-09) for air infiltration/exfiltration.</i>		
5.3.3.2	Water Resistance per ASTM E547		See Note #2
5.3.4.2	Uniform Load Structural per ASTM E330		See Note #2
Note #2:	<i>The client opted to start at a pressure higher than the minimum required. Those results are listed under "Optional Performance".</i>		
Optional Performance			
4.3.2.1	Water Resistance per ASTM E547	**	
5.3.5	Forced Entry resistance per ASTM F588	**	
5.3.6.4.3	Sash Vertical Deflection Test	**	
5.3.6.6.2	Distributed Load Test	**	

**** Please see Specimen 1 of this report for these test results.**

Specimen 5: Optional Performance – Continued

4.4.2.6 Optional Performance

Range	Time (seconds)	Load Pa (psf)	Location	Deflection mm (in.)	Allowable mm (in.)
Half Test Positive	30	1556 (32.50)			
Test Positive	30	3112 (65.00)	1	0.102 (0.004)	See Note #3
Half Test Negative	30	1556 (32.50)			
Test Negative	30	3112 (65.00)	1	0.279 (0.011)	See Note #3

Note #3: *The deflections reported are not limited by AAMA/WDMA/CSA 101/I.S.2/A440-08 (A440S1-09) for this product designation. The deflection data is recorded in this report for special code compliance and information only. See Note #4 for deflection locations.*

Range	Time (seconds)	Load Pa (psf)	Location	Deflection mm(in.)	Set mm(in.)	Allowable mm(in.)
Half Proof Positive	10	2334 (48.75)				
Proof Positive	30	4668 (97.50)	1	0.305 (0.012)	0.102 (0.004)	3.810 (0.150)
Half Proof Negative	10	2334 (48.75)				
Proof Negative	30	4668 (97.50)	1	0.457 (0.018)	0.025 (0.001)	3.810 (0.150)

Note #4: *Deflection/Set for Location 1 measured at center of top rail.*

Test Results: Specimen 6 – Class LC-PG65 1067 x 2134 (42 x 84) Type C – Aluminum Casement Window (X)

The test results are tabulated as follows:

<u>Paragraph</u>	<u>Title of Test – Test Method</u>	<u>Results</u>	<u>Allowed</u>
5.3.1	Operating Force per ASTM E2068-00	**	
5.3.2.1	Air Infiltration per ASTM E283 @ 75 Pa (1.57 psf)	**	
	Air Infiltration per ASTM E283 @ 299 Pa (6.24 psf)	**	
	Air Exfiltration per ASTM E283 @ 75 Pa (1.57 psf)	**	
	Air Exfiltration per ASTM E283 @ 299 Pa (6.24 psf)	**	
Note #1:	<i>The tested specimen meets (or exceeds) the performance levels specified in AAMA/WDMA/CSA 101/I.S.2/A440-08 (A440S1-09) for air infiltration/exfiltration.</i>		
5.3.3.2	Water Resistance per ASTM E547		See Note #2
5.3.4.2	Uniform Load Structural per ASTM E330		See Note #2
Note #2:	<i>The client opted to start at a pressure higher than the minimum required. Those results are listed under "Optional Performance".</i>		
Optional Performance			
4.3.2.1	Water Resistance per ASTM E547	**	
5.3.5	Forced Entry resistance per ASTM F588	**	
5.3.6.4.3	Sash Vertical Deflection Test	**	
5.3.6.6.2	Distributed Load Test	**	

**** Please see Specimen 1 of this report for these test results.**

Specimen 6: Optional Performance – Continued

4.4.2.6 Optional Performance

Range	Time (seconds)	Load Pa (psf)	Location	Deflection mm (in.)	Allowable mm (in.)
Half Test Positive	30	1556 (32.50)			
Test Positive	30	3112 (65.00)	1	0.762 (0.030)	See Note #3
Half Test Negative	30	1556 (32.50)			
Test Negative	30	3112 (65.00)	1	0.914 (0.036)	See Note #3

Note #3: *The deflections reported are not limited by AAMA/WDMA/CSA 101/1.S.2/A440-08 (A440S1-09) for this product designation. The deflection data is recorded in this report for special code compliance and information only. See Note #4 for deflection locations.*

Range	Time (seconds)	Load Pa (psf)	Location	Deflection mm(in.)	Set mm(in.)	Allowable mm(in.)
Half Proof Positive	10	2334 (48.75)				
Proof Positive	30	4668 (97.50)	1	0.813 (0.032)	0.025 (0.001)	3.810 (0.150)
Half Proof Negative	10	2334 (48.75)				
Proof Negative	30	4668 (97.50)	1	1.676 (0.066)	0.305 (0.012)	3.810 (0.150)

Note #4: *Deflection/Set for Location 1 measured at center of top rail.*

Test Results: Specimen 7 – Class LC-PG65 1067 x 4572 (42 x 180) Type AP- Muller Aluminum
Awning/Fixed/Casement Windows (X/O/X))

The test results are tabulated as follows:

<u>Paragraph</u>	<u>Title of Test – Test Method</u>	<u>Results</u>	<u>Allowed</u>
5.3.1	Operating Force per ASTM E2068-00		
	Initiate Motion	9 N (2.0 lbf)	Report Only
	Maintain Motion	7 N (1.5 lbf)	45 N (10.00 lbf)
	Latches	22 N (5.0 lbf)	100 N (22.5 lbf)
5.3.2.1	Air Infiltration per ASTM E283 @ 75 Pa (1.57 psf)	0.070 L/s/m ² (0.014 SCFM/FT ²)	1.5 L/s/m ² (0.30 SCFM/FT ²)
	Air Infiltration per ASTM E283 @ 299 Pa (6.24 psf)	0.420 L/s/m ² (0.084 SCFM/FT ²)	1.5 L/s/m ² (0.30 SCFM/FT ²)
	Air Exfiltration per ASTM E283 @ 75 Pa (1.57 psf)	0.245 L/s/m ² (0.049 SCFM/FT ²)	1.5 L/s/m ² (0.30 SCFM/FT ²)
	Air Exfiltration per ASTM E283 @ 299 Pa (6.24 psf)	0.740 L/s/m ² (0.149 SCFM/FT ²)	1.5 L/s/m ² (0.30 SCFM/FT ²)
Note #1:	<i>The tested specimen meets (or exceeds) the performance levels specified in AAMA/WDMA/CSA 101/I.S.2/A440-08 (A440S1-09) for air infiltration/exfiltration.</i>		
5.3.3.2	Water Resistance per ASTM E547		See Note #2
5.3.4.2	Uniform Load Structural per ASTM E330		See Note #2
Note #2:	<i>The client opted to start at a pressure higher than the minimum required. Those results are listed under "Optional Performance".</i>		
5.3.5	Forced Entry resistance per ASTM F588 Type B Grade 10		
	Disassembly Test	No Entry	No Entry
	Test B1 – B3	No Entry	No Entry
	Sash/Panel Manipulation Test	No Entry	No Entry
	Lock Manipulation Test	No Entry	No Entry
5.3.6.6.6	Awning, Hopper, Projected Hardware Load Test 70N (15 lbf)	46.61 mm (1.835")	No Damage
	Optional Performance		
4.3.2.1	Water Resistance per ASTM E547 (without insect screen) 467 Pa (9.75 psf)	No Leakage	No Leakage

Specimen 7: Optional Performance – Continued

4.4.2.6 Optional Performance

Range	Time (seconds)	Load Pa (psf)	Location	Deflection mm (in.)	Allowable mm (in.)
Half Test Positive	30	1556 (32.50)			
Test Positive	30	3112 (65.00)	1	0.305 (0.012)	See Note #3
Half Test Negative	30	1556 (32.50)			
Test Negative	30	3112 (65.00)	1	0.356 (0.014)	See Note #3

Note #3: *The deflections reported are not limited by AAMA/WDMA/CSA 101/1.S.2/A440-08 (A440S1-09) for this product designation. The deflection data is recorded in this report for special code compliance and information only. See Note #4 for deflection locations.*

Range	Time (seconds)	Load Pa (psf)	Location	Deflection mm(in.)	Set mm(in.)	Allowable mm(in.)
Half Proof Positive	10	2334 (48.75)				
Proof Positive	30	4668 (97.50)	1	0.533 (0.021)	0.102 (0.004)	3.810 (0.168)
Half Proof Negative	10	2334 (48.75)				
Proof Negative	30	4668 (97.50)	1	0.864 (0.034)	0.381 (0.015)	3.810 (0.168)

Note #4: *Deflection/Set for Location 1 measured at center of top rail.*

Test Results: Specimen 8 – Class LC-PG65 1067 x 4572 (42 x 180) Type AP- Muller Aluminum
Fixed/Awning/Fixed Windows (O/X/O)

The test results are tabulated as follows:

<u>Paragraph</u>	<u>Title of Test – Test Method</u>	<u>Results</u>	<u>Allowed</u>
5.3.1	Operating Force per ASTM E2068-00		
	Initiate Motion	9 N (2.1 lbf)	Report Only
	Maintain Motion	9 N (2.0 lbf)	45 N (10.00 lbf)
	Latches	22 N (5.0 lbf)	100 N (22.5 lbf)
5.3.2.1	Air Infiltration per ASTM E283 @ 75 Pa (1.57 psf)	0.110 L/s/m ² (0.021 SCFM/FT ²)	1.5 L/s/m ² (0.30 SCFM/FT ²)
	Air Infiltration per ASTM E283 @ 299 Pa (6.24 psf)	0.095 L/s/m ² (0.019 SCFM/FT ²)	1.5 L/s/m ² (0.30 SCFM/FT ²)
	Air Exfiltration per ASTM E283 @ 75 Pa (1.57 psf)	0.530 L/s/m ² (0.106 SCFM/FT ²)	1.5 L/s/m ² (0.30 SCFM/FT ²)
	Air Exfiltration per ASTM E283 @ 299 Pa (6.24 psf)	1.660 L/s/m ² (0.322 SCFM/FT ²)	1.5 L/s/m ² (0.30 SCFM/FT ²)
Note #1:	<i>The tested specimen meets (or exceeds) the performance levels specified in AAMA/WDMA/CSA 101/I.S.2/A440-08 (A440S1-09) for air infiltration/exfiltration.</i>		
5.3.3.2	Water Resistance per ASTM E547		See Note #2
5.3.4.2	Uniform Load Structural per ASTM E330		See Note #2
Note #2:	<i>The client opted to start at a pressure higher than the minimum required. Those results are listed under "Optional Performance".</i>		
5.3.5	Forced Entry resistance per ASTM F588 Type B Grade 10		
	Disassembly Test	No Entry	No Entry
	Test B1 – B3	No Entry	No Entry
	Sash/Panel Manipulation Test	No Entry	No Entry
	Lock Manipulation Test	No Entry	No Entry
5.3.6.6.6	Awning, Hopper, Projected Hardware Load Test 70N (15 lbf)	48.57 mm (1.912")	No Damage
	Optional Performance		
4.3.2.1	Water Resistance per ASTM E547 (without insect screen) 467 Pa (9.75 psf)	No Leakage	No Leakage

Specimen 8: Optional Performance – Continued

4.4.2.6 Optional Performance

Range	Time (seconds)	Load Pa (psf)	Location	Deflection mm (in.)	Allowable mm (in.)
Half Test Positive	30	1556 (32.50)			
Test Positive	30	3112 (65.00)	1	0.127 (0.005)	See Note #3
Half Test Negative	30	1556 (32.50)			
Test Negative	30	3112 (65.00)	1	0.178 (0.007)	See Note #3

Note #3: *The deflections reported are not limited by AAMA/WDMA/CSA 101/1.S.2/A440-08 (A440S1-09) for this product designation. The deflection data is recorded in this report for special code compliance and information only. See Note #4 for deflection locations.*

Range	Time (seconds)	Load Pa (psf)	Location	Deflection mm(in.)	Set mm(in.)	Allowable mm(in.)
Half Proof Positive	10	2334 (48.75)				
Proof Positive	30	4668 (97.50)	1	0.559 (0.022)	0.051 (0.002)	3.810 (0.168)
Half Proof Negative	10	2334 (48.75)				
Proof Negative	30	4668 (97.50)	1	1.118 (0.044)	0.102 (0.004)	3.810 (0.168)

Note #4: *Deflection/Set for Location 1 measured at center of top rail.*

Test Results: Specimen 12 – Class LC-PG65 1067 x 1829 (42 x 72) Type C – Aluminum Casement Window (X)

The test results are tabulated as follows:

<u>Paragraph</u>	<u>Title of Test – Test Method</u>	<u>Results</u>	<u>Allowed</u>
5.3.1	Operating Force per ASTM E2068-00	**	
5.3.2.1	Air Infiltration per ASTM E283 @ 75 Pa (1.57 psf)	**	
	Air Infiltration per ASTM E283 @ 299 Pa (6.24 psf)	**	
	Air Exfiltration per ASTM E283 @ 75 Pa (1.57 psf)	**	
	Air Exfiltration per ASTM E283 @ 299 Pa (6.24 psf)	**	
Note #1:	<i>The tested specimen meets (or exceeds) the performance levels specified in AAMA/WDMA/CSA 101/I.S.2/A440-08 (A440S1-09) for air infiltration/exfiltration.</i>		
5.3.3.2	Water Resistance per ASTM E547		See Note #2
5.3.4.2	Uniform Load Structural per ASTM E330		See Note #2
Note #2:	<i>The client opted to start at a pressure higher than the minimum required. Those results are listed under "Optional Performance".</i>		
Optional Performance			
4.3.2.1	Water Resistance per ASTM E547	**	
5.3.5	Forced Entry resistance per ASTM F588	**	
5.3.6.4.3	Sash Vertical Deflection Test	**	
5.3.6.6.2	Distributed Load Test	**	

**** Please see Specimen 1 of this report for these test results.**

Specimen 12: Optional Performance – Continued

4.4.2.6 Optional Performance

Range	Time (seconds)	Load Pa (psf)	Location	Deflection mm (in.)	Allowable mm (in.)
Half Test Positive	30	1556 (32.50)			
Test Positive	30	3112 (65.00)	1	1.753 (0.069)	See Note #3
Half Test Negative	30	1556 (32.50)			
Test Negative	30	3112 (65.00)	1	2.159 (0.085)	See Note #3

Note #3: *The deflections reported are not limited by AAMA/WDMA/CSA 101/1.S.2/A440-08 (A440S1-09) for this product designation. The deflection data is recorded in this report for special code compliance and information only. See Note #4 for deflection locations.*

Range	Time (seconds)	Load Pa (psf)	Location	Deflection mm(in.)	Set mm(in.)	Allowable mm(in.)
Half Proof Positive	10	2334 (48.75)				
Proof Positive	30	4668 (97.50)	1	2.007 (0.079)	1.245 (0.049)	3.810 (0.150)
Half Proof Negative	10	2334 (48.75)				
Proof Negative	30	4668 (97.50)	1	2.845 (0.112)	1.600 (0.063)	3.810 (0.150)

Note #4: *Deflection/Set for Location 1 measured at center of top rail.*

Conditions, Terms, and General Notes Regarding These Tests

The product tested Has Been compared to the detailed drawing, bill of materials and fabrication information supplied by the client so named herein. Our analysis, which includes dimensional and component description comparisons, indicate the tested product and engineering information supplied by the client "Are Equivalent". The report and representative samples will be retained for four years from the date of initial test.

These test results were obtained by employing all requirements of the designated test methods with no Deviations unless explicitly noted in test report. The test results and specimen supplied for testing are in compliance with the reference.

The test results are specific to the product tested by this laboratory and of the sample supplied by the client named herein, and they relate to no other product either manufactured by the client, a fabricator of the client or of the client or of installed field performance.

This test report does not constitute certification of this product, but only that the above test results were obtained using the designated test methods and they indicate compliance with the performance requirements (paragraphs as listed) of the above referenced specifications.

Testing Evaluation Laboratories, Inc. makes no opinions or endorsements regarding this product and its performance. This report may not be reproduced or quoted in partial form without the expressed written approval of Testing Evaluation Laboratories, Inc.

Testing Evaluation Laboratories, Inc.'s letter, reports, its name or insignia or mark are for the exclusive use of the client so named herein and any other use is strictly prohibited. The report, letters and the name of Testing Evaluation Laboratories, Inc., its seal or mark shall not be used in any circumstance to the general public or in any advertising.

Limitation of liability: Due diligence was used in performing the tests and reporting the results. By acceptance of this report, this client agrees to hold harmless and indemnify Testing Evaluation Laboratories, Inc., its employees and officers and owners against all claims and demands of any kind whatsoever, which arise out of or in any manner connected with the performance of work referred to herein.

Testing Evaluation Laboratories, Inc.



Vivian K. Wright,
President

Revision Log

Rev No.	Date	Page(s)	Revision(s)
0	10/21/2013	NA	Original Report Issue

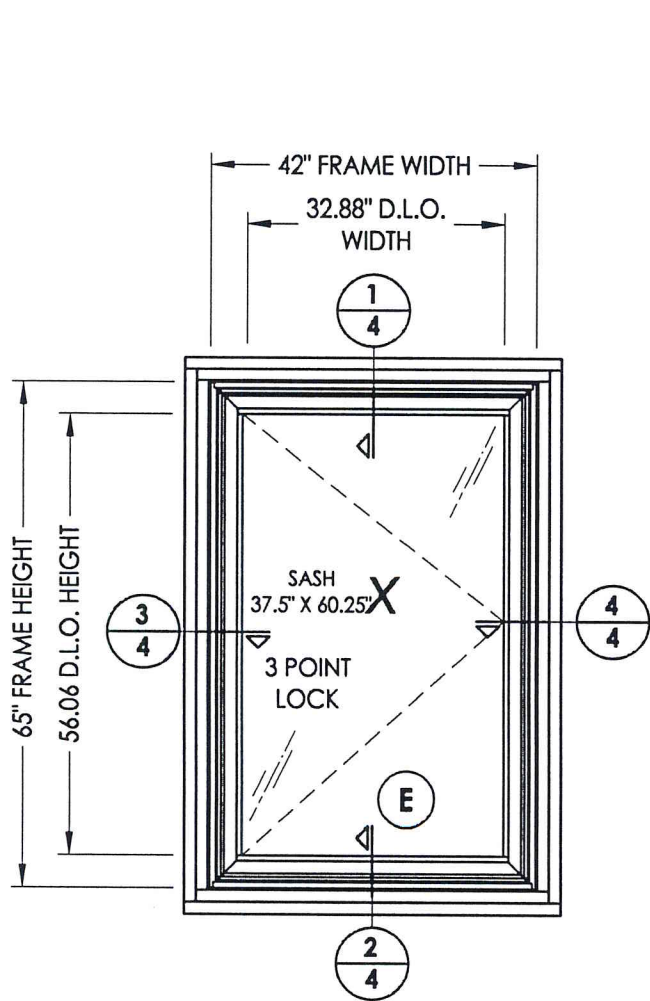

SPEC. #3, 3A

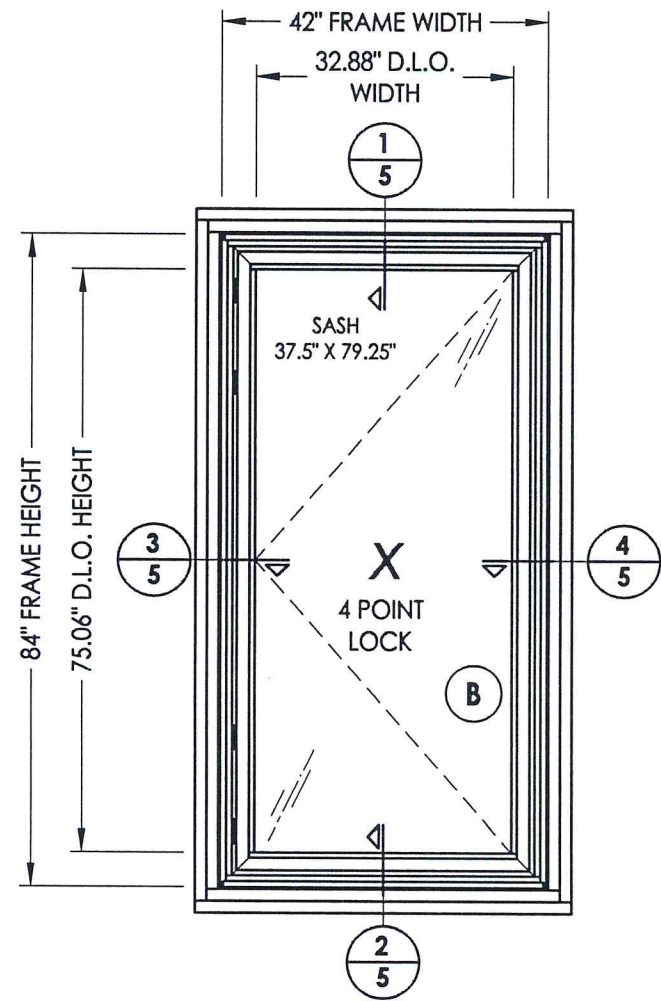

SPEC. #1, 1A, 1B, 1C

Testing Evaluation Laboratories Inc
 Specimen Complies with Drawing
 Deviations Noted - TEL # 01990817
 Date 10-31-13 Verified by gn

PRODUCT:		FLEETWOOD KONA 3800 CASEMENT WINDOW	
PART OR ASSEMBLY:		TEST ELEVATION	
NO.	DATE	BY	REVISIONS
RW BUILDING CONSULTANTS, INC. 813.659.9197			
DATE: 9/25/13			
SCALE: N.T.S.			
DWG. BY: JK			
CHK. BY: LFS			
DRAWING NO.: L-7031			
SHEET 2 OF 13			

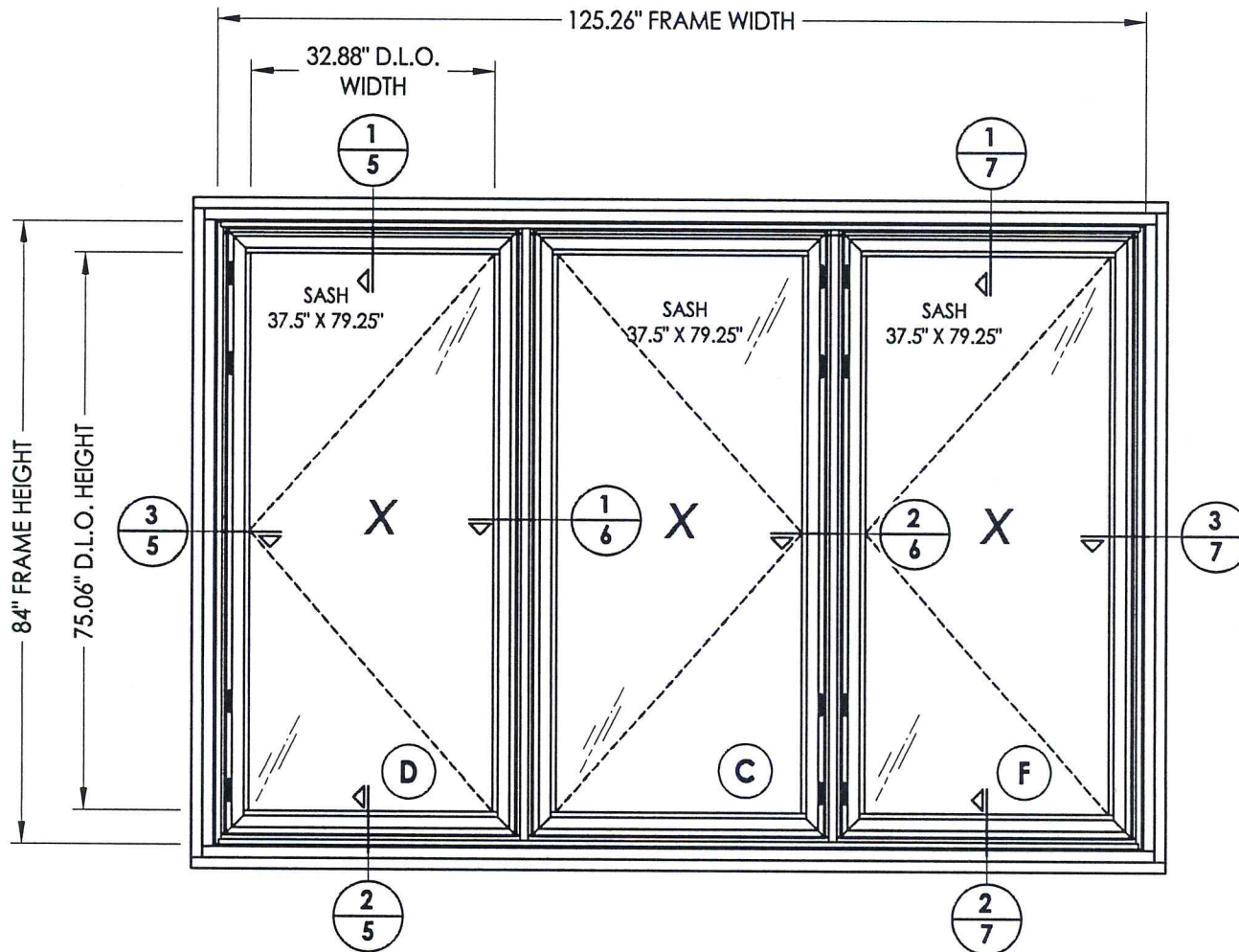

SPEC. #4, 4A

Testing Evaluation Laboratories Inc
Specimen Complies with Drawing
Deviations Noted - TEL # 01990817
Date 10-31-13 Verified by gw

PRODUCT: FLEETWOOD
 KONA 3800
 CASEMENT WINDOW

PART OR ASSEMBLY: TEST ELEVATION

NO.	DATE	BY	REVISIONS

RW BUILDING
CONSULTANTS, INC.
 813.659.9197

DATE: 9/25/13
 SCALE: N.T.S.
 DWG. BY: JK
 CHK. BY: LFS
 DRAWING NO.: L-7031
 SHEET 3 OF 13

R:\VA - Project\Folders\Project Folders\Proj 1701 - 1800\PF 1731\1.D. RWBC Drawings\L-7031.dwg

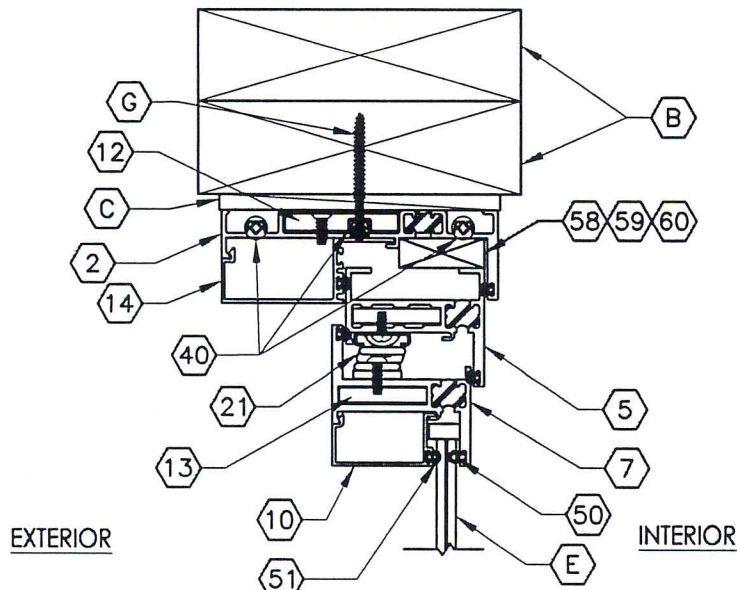

1
4 VERTICAL CROSS SECTION

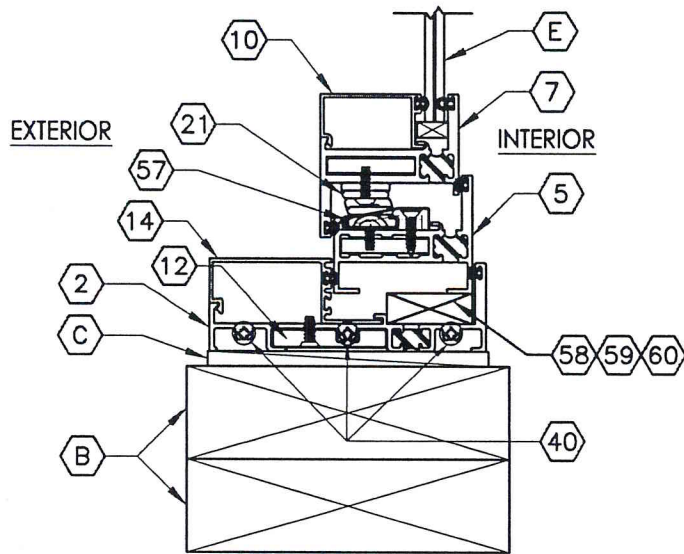

2
4 VERTICAL CROSS SECTION

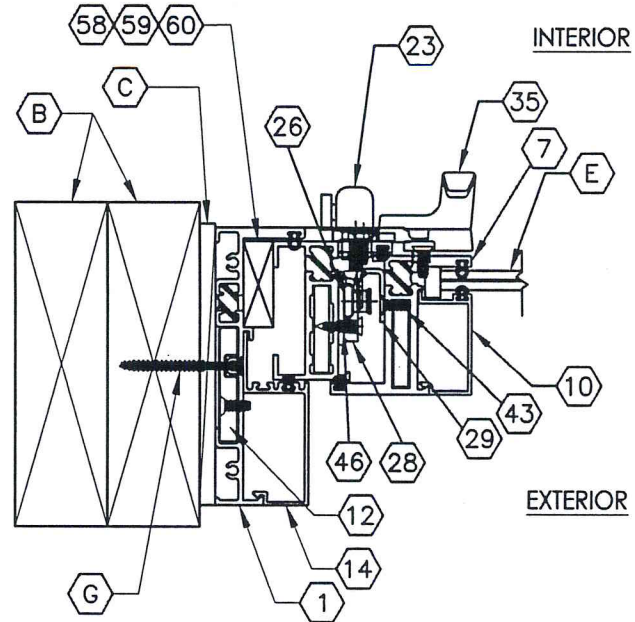

3
4 HORIZONTAL CROSS SECTION
Testing Facilities Laboratories Inc
Specimen Complies with Drawing
Deviations Noted - TEL # 01990817
Date 10-21-13 Verified by gw

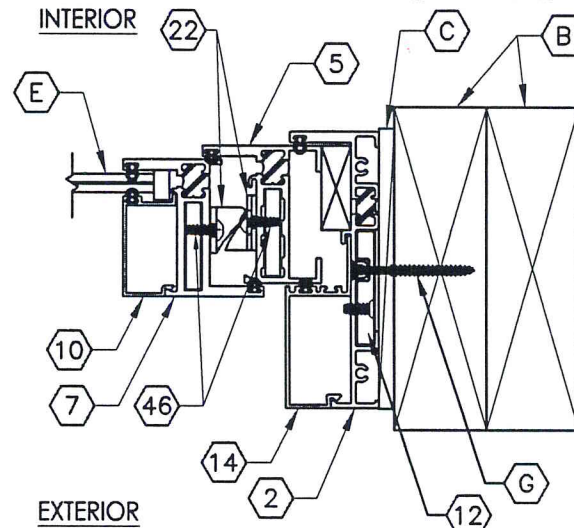

4
4 HORIZONTAL CROSS SECTION

PRODUCT:

FLEETWOOD
KONA 3800
CASEMENT WINDOW

PART OR ASSEMBLY:

HORIZONTAL AND VERTICAL
CROSS SECTIONS

NO.	DATE	BY	REVISIONS

RW BUILDING
CONSULTANTS, INC.
813.659.9197

DATE: 9/25/13

SCALE: N.T.S.

DWG. BY: JK

CHK. BY: LFS

DRAWING NO.:

L-7031

SHEET 4 OF 13

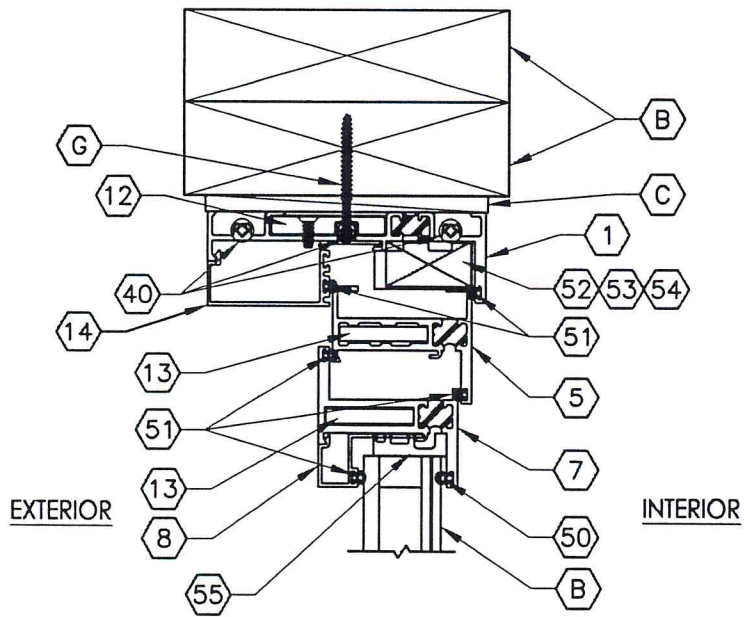

1
5 VERTICAL CROSS SECTION

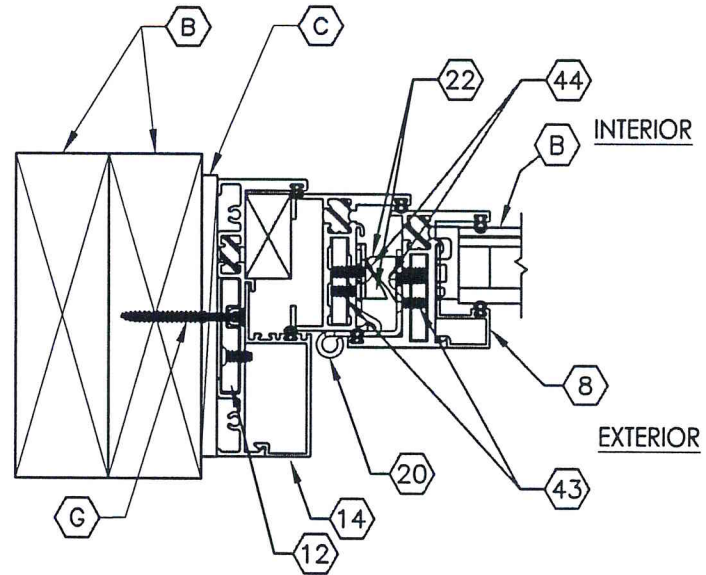

3
5 HORIZONTAL CROSS SECTION

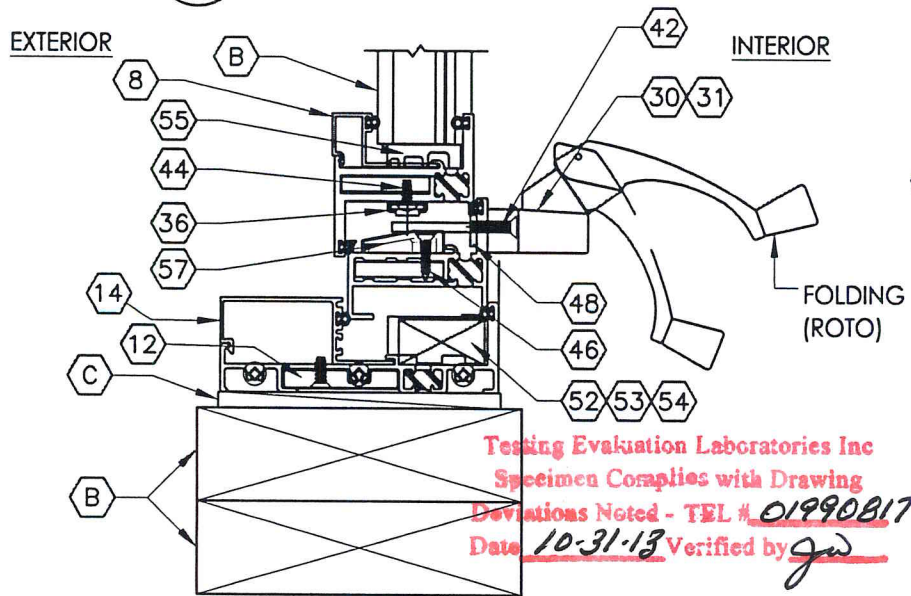

2
5 VERTICAL CROSS SECTION

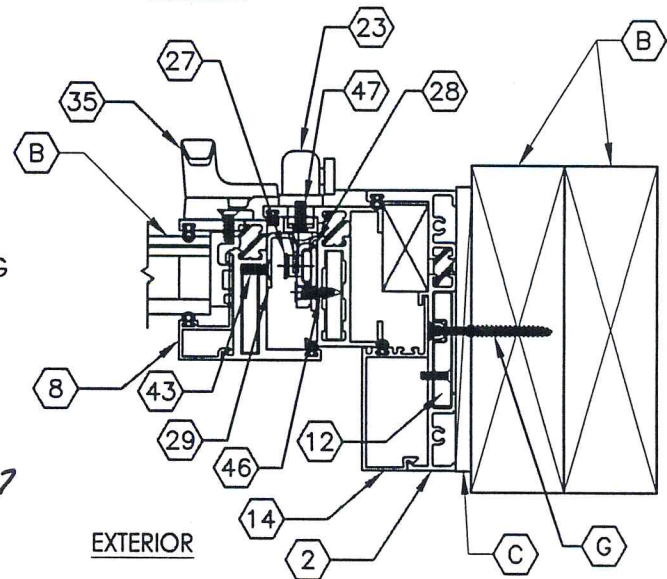

4
5 HORIZONTAL CROSS SECTION

Testing Evaluation Laboratories Inc
 Specimen Complies with Drawing
 Deviations Noted - TEL # 01990817
 Date 10-31-13 Verified by *gaw*

PRODUCT: FLEETWOOD KONA 3800 CASEMENT WINDOW		PART OR ASSEMBLY: HORIZONTAL AND VERTICAL CROSS SECTIONS	
NO.	DATE	REVISIONS	BY
 RW BUILDING CONSULTANTS, INC. 813.659.9197			
DATE: 9/25/13			
SCALE: N.T.S.			
DWG. BY: JK			
CHK. BY: LFS			
DRAWING NO.: L-7031			
SHEET 5 OF 13			

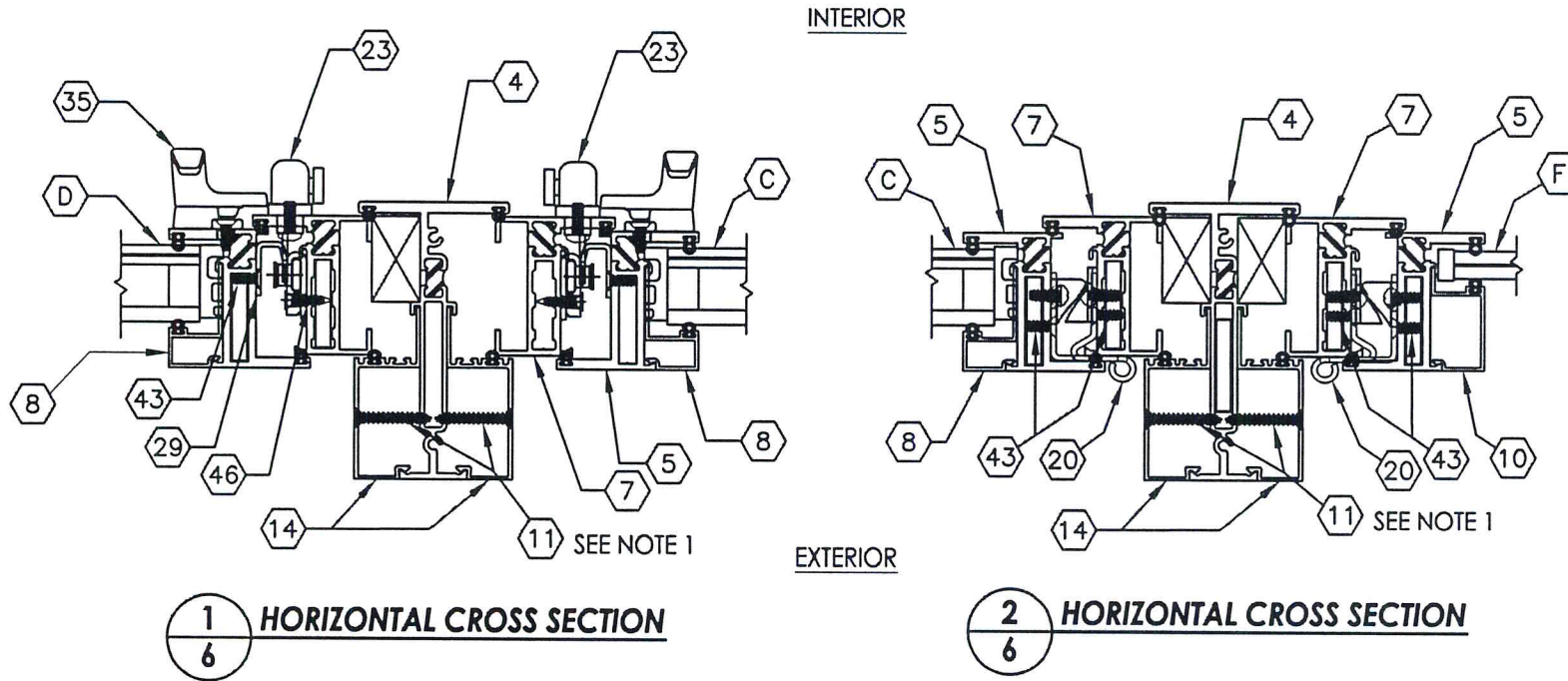

NOTE:

- Item #11 located 4" from each end then 12" on center for (8) total.

Testing Evaluation Laboratories Inc
 Specimen Complies with Drawing
 Deviations Noted - TEL # 01990817
 Date 10-31-13 Verified by gw

PRODUCT: FLEETWOOD KONA 3800 CASEMENT WINDOW		PART OR ASSEMBLY: HORIZONTAL CROSS SECTIONS	
NO.	DATE	REVISIONS	BY
DATE: 9/25/13			
SCALE: N.T.S.			
DWG. BY: JK			
CHK. BY: LFS			
DRAWING NO.: L-7031			
SHEET 6 OF 13			

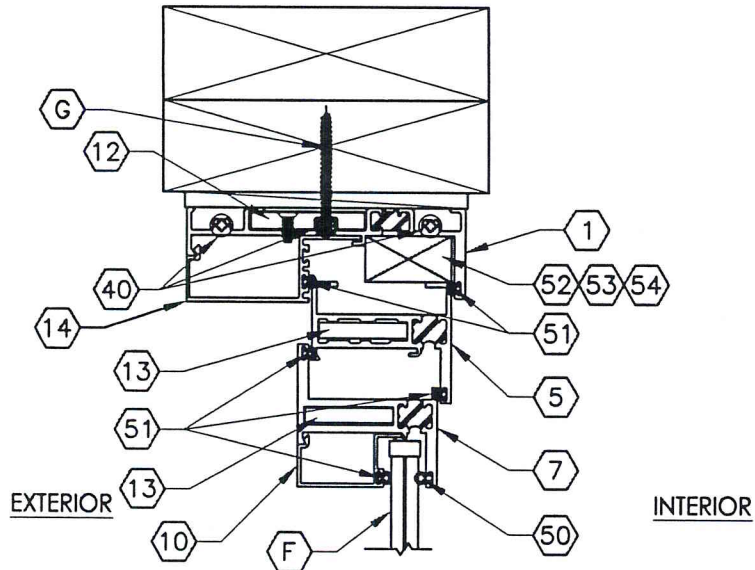

1
7 VERTICAL CROSS SECTION

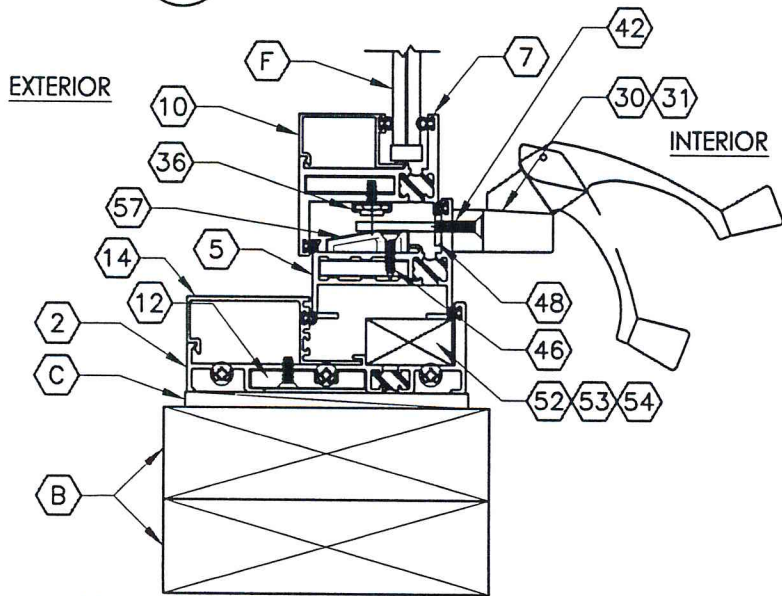

2
7 VERTICAL CROSS SECTION

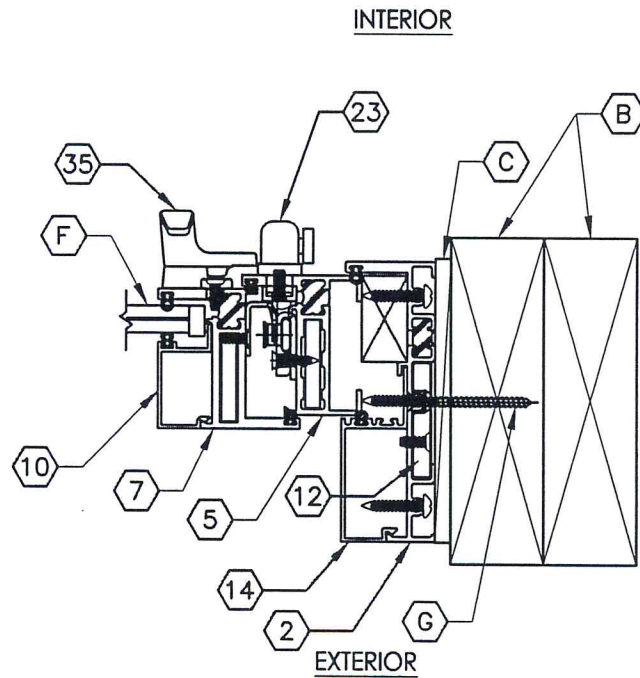

3
7 HORIZONTAL CROSS SECTION

Testing Evaluation Laboratories Inc
 Specimen Complies with Drawing
 Deviations Noted - TEL # 01990817
 Date 10.31.13 Verified by *JW*

PRODUCT: FLEETWOOD KONA 3800 CASEMENT WINDOW		PART OR ASSEMBLY: HORIZONTAL AND VERTICAL CROSS SECTIONS	
NO.	DATE	REVISIONS	BY
 RW BUILDING CONSULTANTS, INC. 813.659.9197			
DATE: 9/25/13			
SCALE: N.T.S.			
DWG. BY: JK			
CHK. BY: LFS			
DRAWING NO.: L-7031			
SHEET 7 OF 13			

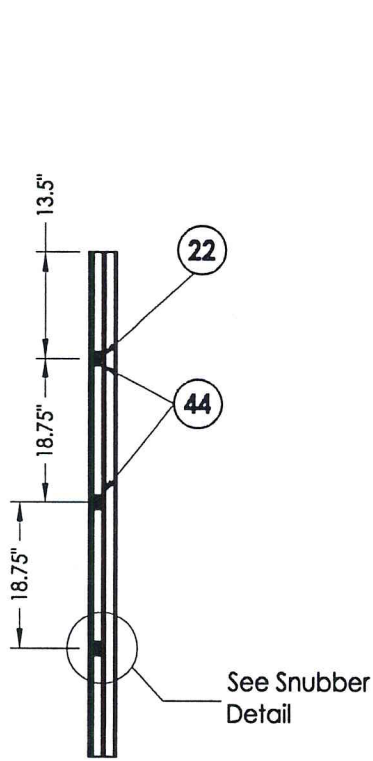

SNUBBERS JAMB

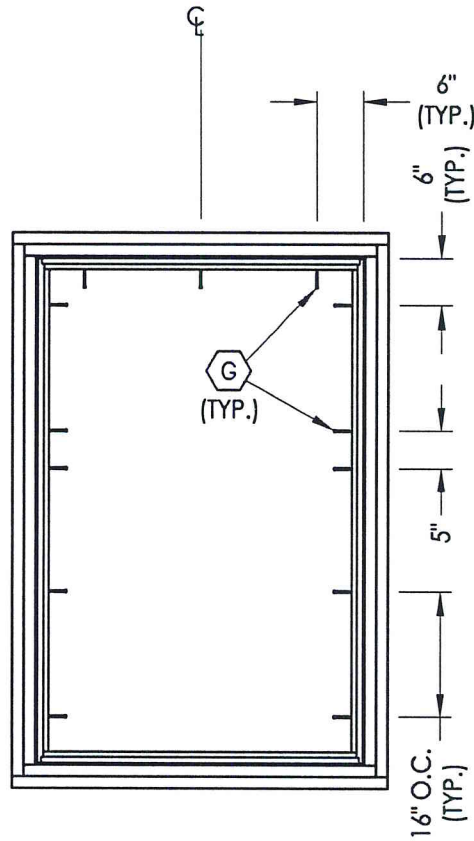

FRAME ANCHORING
2X buck construction

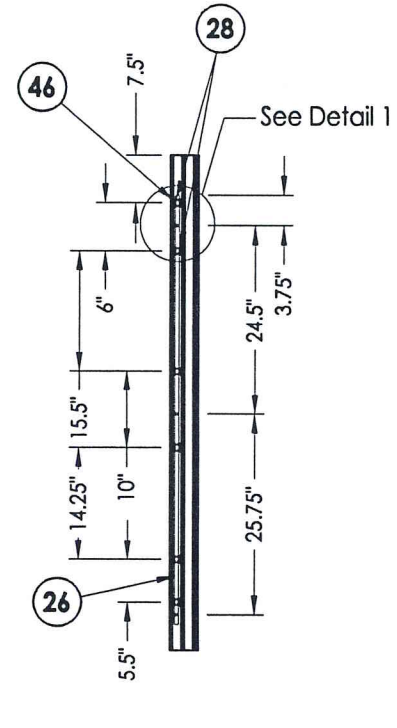

LOCK JAMB
Locking Points (3)

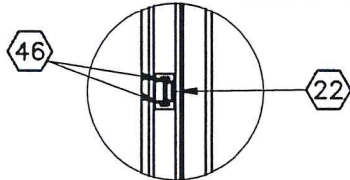

SNUBBER DETAIL

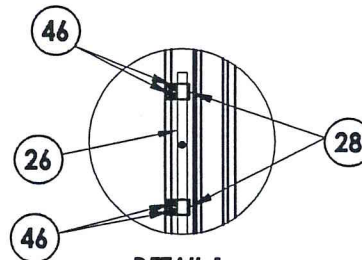

DETAIL 1

Testing Evaluation Laboratories Inc
 Specimen Complies with Drawing
 Deviations Noted - TEL # 01990817
 Date 10-31-13 Verified by JW

PRODUCT:

FLEETWOOD
KONA 3800
CASEMENT WINDOW

PART OR ASSEMBLY:

FRAME ANCHORING

NO.	DATE	REVISIONS	BY

RW BUILDING
CONSULTANTS, INC.
813.659.9197

DATE: 9/25/13

SCALE: N.T.S.

DWG. BY: JK

CHK. BY: LFS

DRAWING NO.:

L-7031

SHEET 8 OF 13

Testing Evaluation Laboratories Inc
 Specimen Complies with Drawing
 Deviations Noted - TEL # 01990817
 Date 10-31-13 Verified by gw

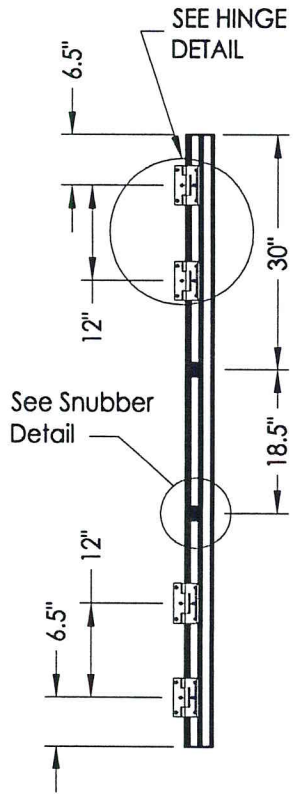

HINGE JAMB

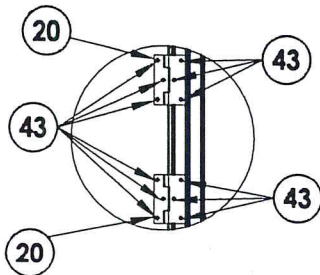

HINGE DETAIL

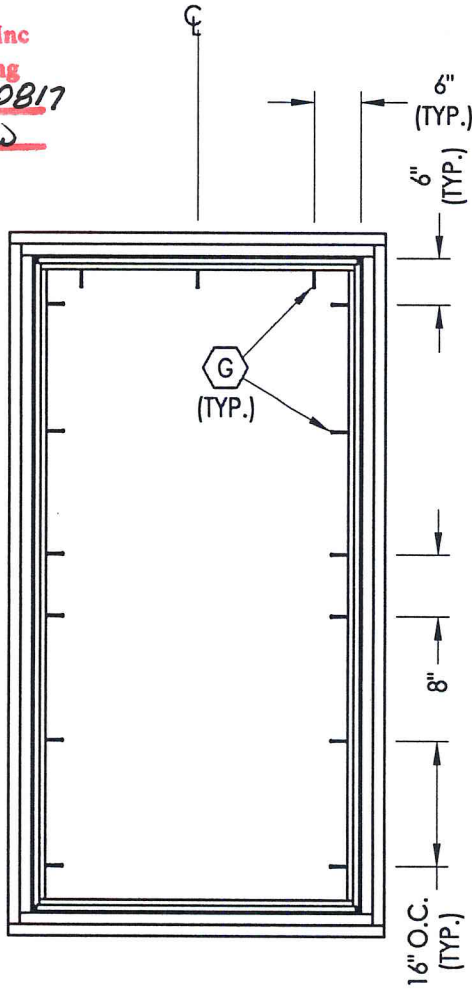

FRAME ANCHORING
2X buck construction

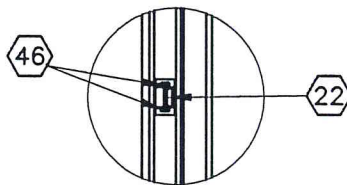

SNUBBER DETAIL

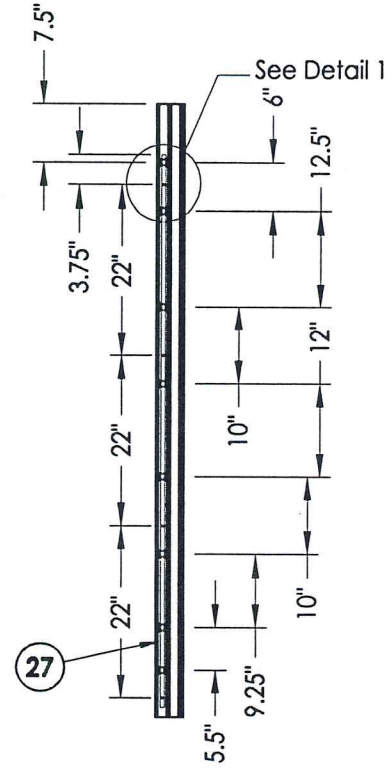

LOCK JAMB
Locking Points (4)

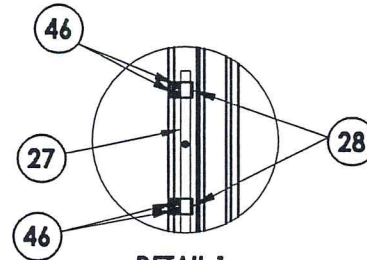

DETAIL 1

PRODUCT: FLEETWOOD KONA 3800 CASEMENT WINDOW		PART OR ASSEMBLY: FRAME ANCHORING	
NO.	DATE	BY	REVISIONS
DATE: 9/25/13			
SCALE: N.T.S.			
DWG. BY: JK			
CHK. BY: LFS			
DRAWING NO.: L-7031			
SHEET 9 OF 13			

R:\A - Projects\Project Folders\Proj 1701 - 1800\PF 1731\D. RWBC Drawings\L-7031.dwg

Testing Evaluation Laboratories Inc
 Specimen Complies with Drawing
 Deviations Noted - TEL # 01990817
 Date 10.31.13 Verified by gfw

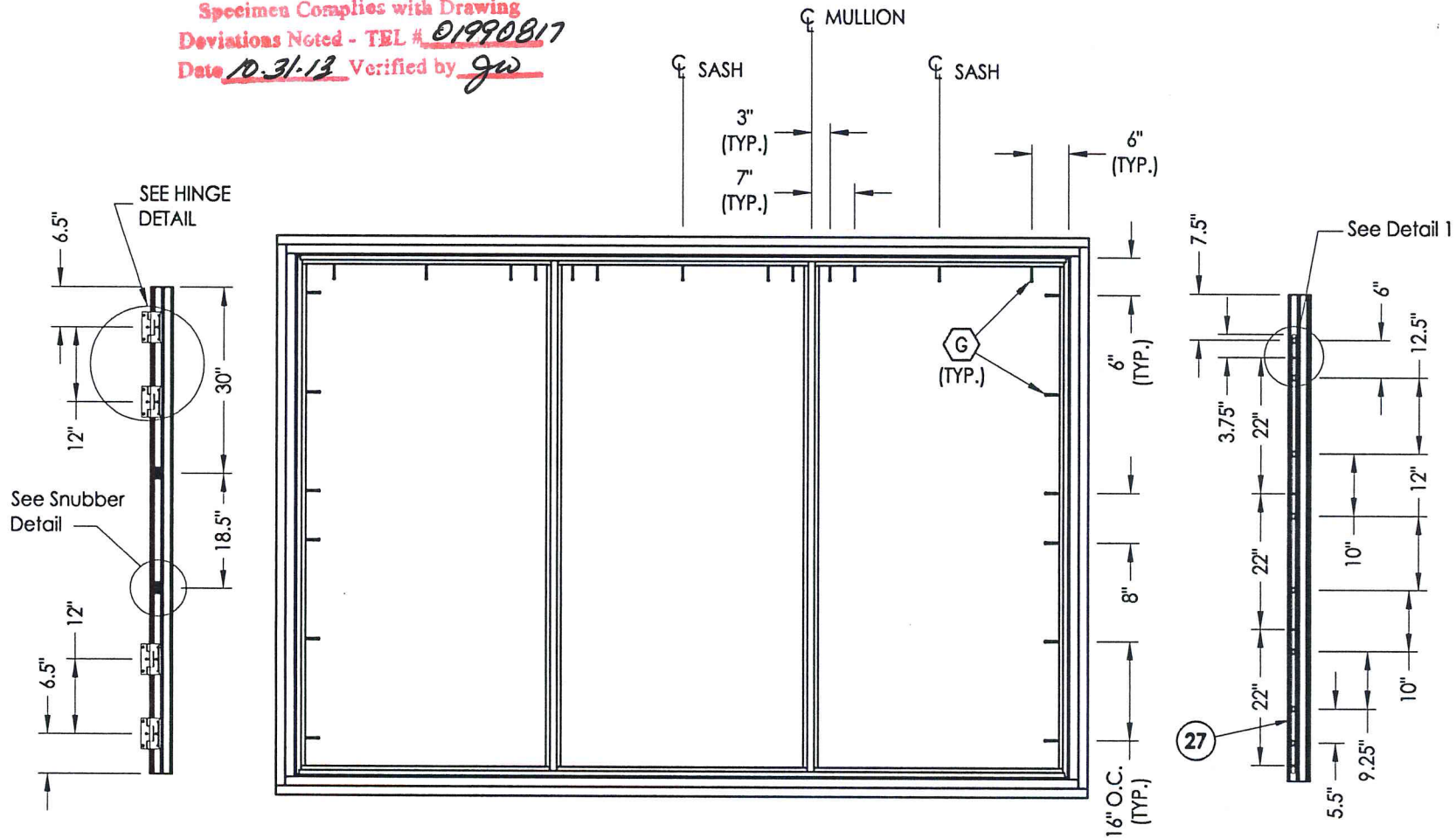

HINGE JAMB

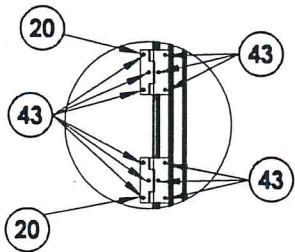

HINGE DETAIL

FRAME ANCHORING
2X buck construction

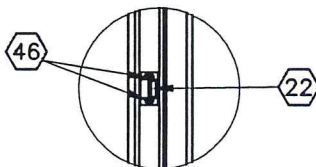

SNUBBER DETAIL

LOCK JAMB

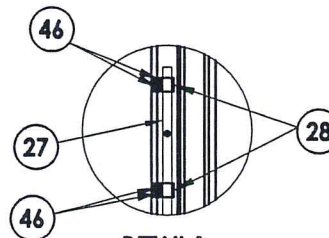

DETAIL 1

PRODUCT:

FLEETWOOD
KONA 3800
CASEMENT WINDOW

PART OR ASSEMBLY:

FRAME ANCHORING

NO.	DATE	REVISIONS	BY

RW BUILDING CONSULTANTS, INC.
813.659.9197

DATE: 9/25/13
 SCALE: N.T.S.
 DWG. BY: JK
 CHK. BY: LFS
 DRAWING NO.: L-7031
 SHEET 10 OF 13

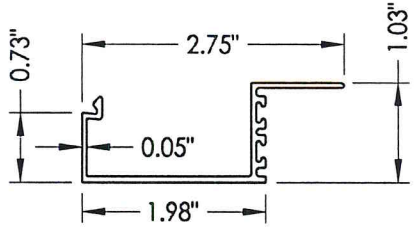

14 INSERT STOP
011448

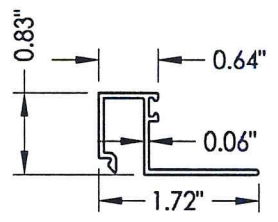

8 GLASS STOP 1-1/4"
901487

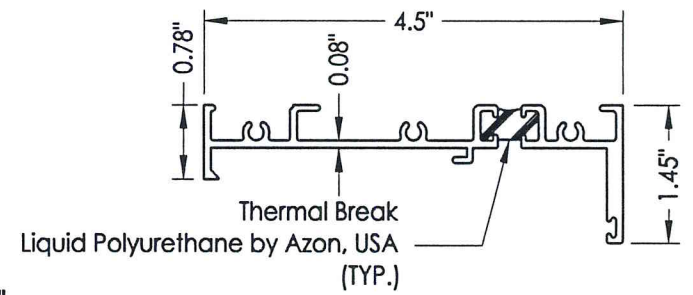

2 KONA BLOCK FRAME
011239

Testing Evaluation Laboratories Inc
 Specimen Complies with Drawing
 Deviations Noted - TEL # 01990817
 Date 10-31-13 Verified by Jed

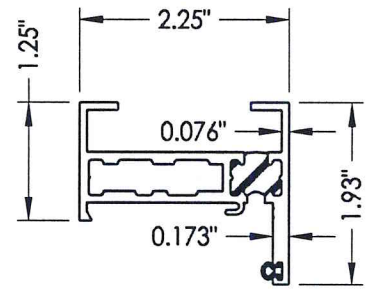

5 BLOCK FRAME
5278C1

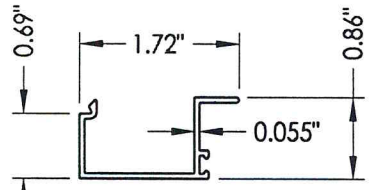

10 GLASS STOP 5/16\", 7/16"
007930

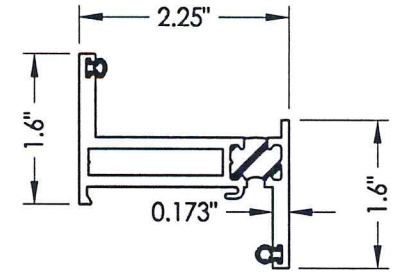

7 ZEE BAR (PANEL)
H006733

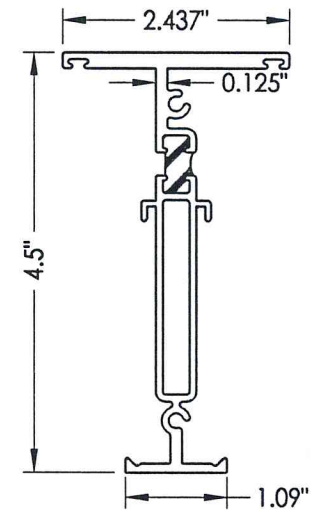

4 MULLION
H011241

PRODUCT: FLEETWOOD KONA 3800 CASEMENT WINDOW		PART OR ASSEMBLY: COMPONENTS	
NO.	DATE	REVISIONS	BY
DATE: 9/25/13			
SCALE: N.T.S.			
DWG. BY: JK			
CHK. BY: LFS			
DRAWING NO.: L-7031			
SHEET 11 OF 13			

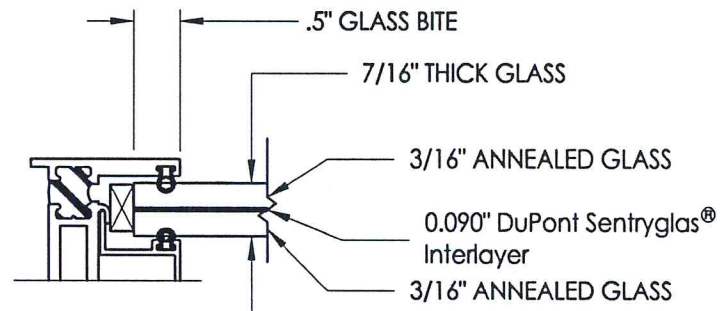
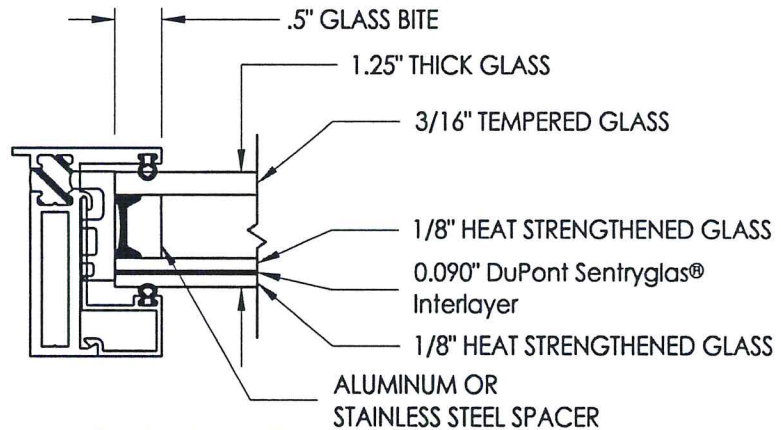
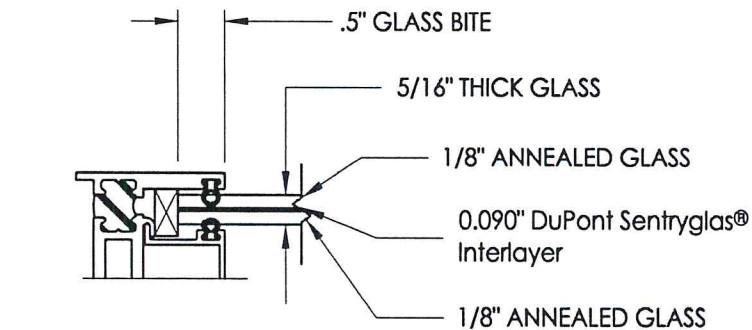
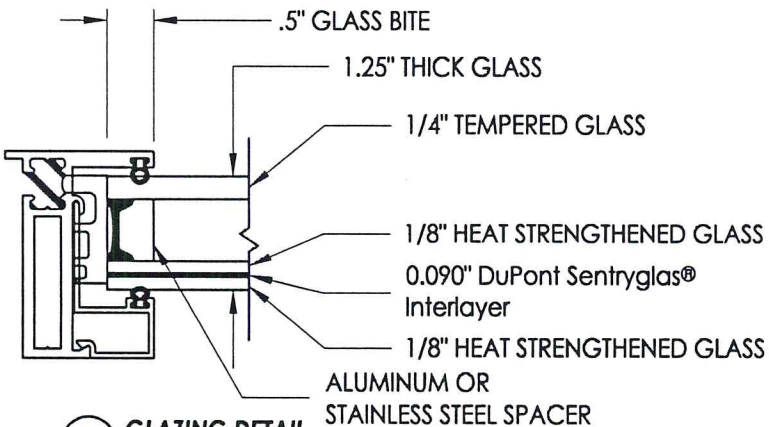
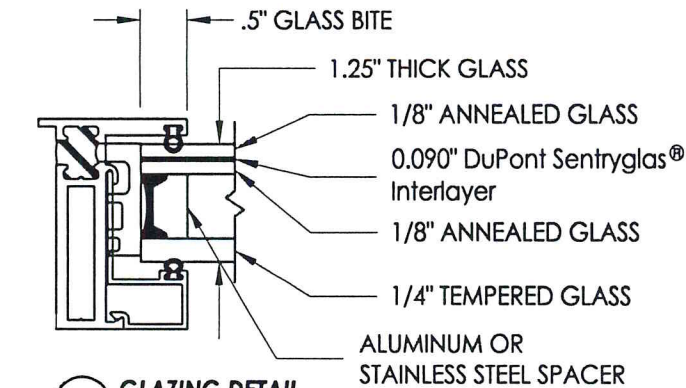

Testing Evaluation Laboratories Inc
 Specimen Complies with Drawing
 Deviations Noted - TEL # 01990817
 Date 10-31-13 Verified by gw

PRODUCT: FLEETWOOD KONA 3800 CASEMENT WINDOW		PART OR ASSEMBLY:		GLAZING DETAILS	
NO.	DATE	REVISIONS	BY		
DATE: 9/25/13					
SCALE: N.T.S.					
DWG. BY: JK					
CHK. BY: LFS					
DRAWING NO.: L-7031					
SHEET 12 OF 13					

BILL OF MATERIALS		
ITEM #	DESCRIPTION	MATERIAL
B	2X BUCK SG >= 0.55	WOOD
C	1/4" MAX. SHIM SPACE	-
G	#10 x 2" PPH WOOD SCREW	STEEL
2	KONA BLOCK FRAME	6063-T6 ALUM
4	MULLION	6063-T6 ALUM
5	WESTWOOD BLOCK FRAME	6063-T6 ALUM
7	WESTWOOD ZEE BAR (PANEL)	6063-T6 ALUM
8	GLASS STOP (1-1/4")	6063-T6 ALUM
9	GLASS STOP (1/4")	6063-T6 ALUM
10	GLASS STOP (5/16", 7/16")	6063-T6 ALUM
11	#8 x 1-1/2" PFH SMS	STEEL
12	SHEAR BLOCK	ALUM
13	CORNER KEY	ALUM
14	INSERT STOP	6063-T6 ALUM
20	SS. BUTT HINGE	SS
21	4 BAR HINGE	SS
22	SNUBBER-COMMERCIAL PULL-IN BLOCK	SS
23	MULTIPOINT LOCK HANDLE	SS
26	3 POINTS LOCKING BAR	SS
27	4 POINTS LOCKING BAR	SS
28	TIE BAR GUIDE	-
29	KEEPER	SS
30	CASEMENT ROTOR GEAR 13.5"	SS
35	CAM HANDLE / STRIKE PLATE	SS

36	CASEMENT SS. TRACK	SS
40	#10 X 1" PPH SMS	STEEL
42	MACHINE SCREW NO 10-32, FHP .75"	STEEL
43	SCREW NO 10 , UFHP .5"	STEEL
44	SCREW NO 8, PHP, .50"	STEEL
46	SCREW NO 8, FHP, .750"	STEEL
47	MACHINE SCREW NO 10-32, PHP .5"	STEEL
48	BACK UP NUTS	STEEL
50	BULB VINYL (EPDM 70 DUROMETER)-TREMCO	-
51	MINI BULB VINYL(EPDM 70 DUROMETER)-TREMCO	-
52	WOOD BLOCK .750" X 1.250"	-
53	ALUMINUM BLOCK .750" X 1.250"	-
54	PVC BLOCK .750" X 1.250"	-
55	SETTING BLOCK	-
56	SETTING BLOCK 4" x 1/4" x 1"	-
57	PIVOT SHIM	-
58	WOOD BLOCK .50" X 1.250"	-
59	ALUMINUM BLOCK .50" X 1.250"	-
60	PVC BLOCK .50" X 1.250"	-
61	SETTING BLOCK 4" x 1/8" x 1"	-

Testing Evaluation Laboratories Inc
 Specimen Complies with Drawing
 Deviations Noted - TEL # 01990817
 Date 10-31-13 Verified by JW

PRODUCT:	FLEETWOOD KONA 3800 CASEMENT WINDOW			
PART OR ASSEMBLY:	BILL OF MATERIALS			
NO.	DATE	BY	REVISIONS	
<div style="border: 1px solid black; padding: 5px; margin: 5px;">  </div>				
DATE: 9/25/13				
SCALE: N.T.S.				
DWG. BY: JK				
CHK. BY: LFS				
DRAWING NO.: L-7031				
SHEET 13 OF 13				

TABLE OF CONTENTS

SHEET #	DESCRIPTION
1	Table of contents
2	Test elevation
3	Vertical cross sections
4	Horizontal cross sections
5	Horizontal cross sections
6	Horizontal cross sections
7	Vertical cross sections
8	Frame anchoring
9	Frame anchoring
10	Components
11	Glazing details
12	Bill of materials

Testing Evaluation Laboratories Inc
 Specimen Complies with Drawing
 Deviations Noted - TEL # 01990187
 Date 10-31-13 Verified by JW

PRODUCT:	FLEETWOOD KONA 3800 CASEMENT WINDOW				
PART OR ASSEMBLY:	TABLE OF CONTENTS				
			REVISIONS		
		DATE	BY		
<table border="1" style="margin: auto;"> <tr> <td style="font-size: 2em; font-weight: bold;">RW</td> <td style="font-size: 0.8em; padding-left: 5px;">BUILDING CONSULTANTS, INC. 813.659.9197</td> </tr> </table>				RW	BUILDING CONSULTANTS, INC. 813.659.9197
RW	BUILDING CONSULTANTS, INC. 813.659.9197				
DATE: 9/25/13					
SCALE: N.T.S.					
DWG. BY: JK					
CHK. BY: LFS					
DRAWING NO.: L-7032					
SHEET <u>1</u> OF <u>12</u>					

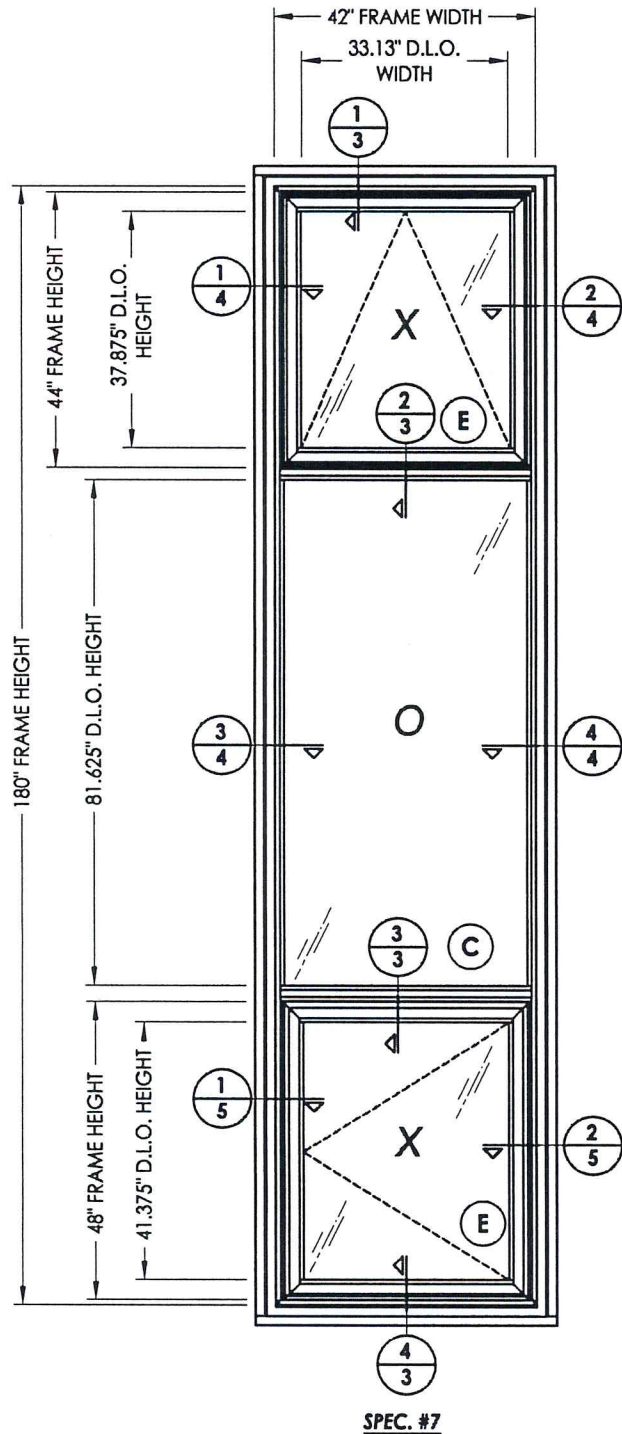

SPEC. #7

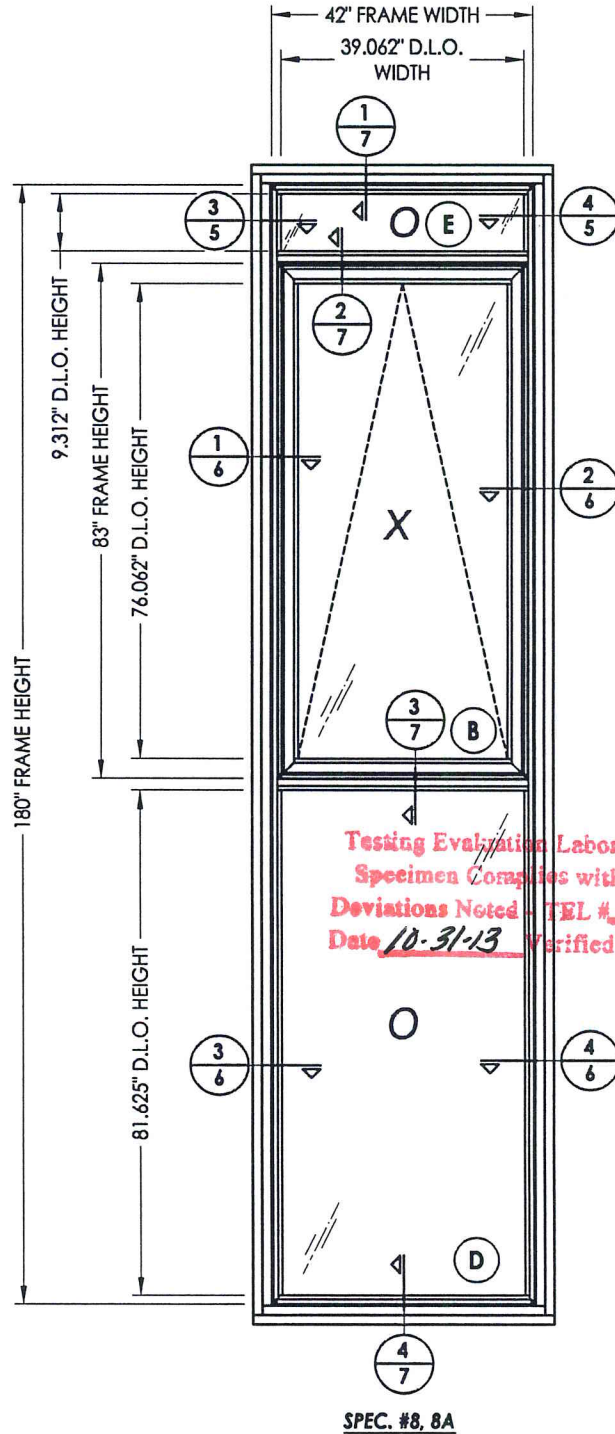

SPEC. #8, 8A

Testing Evaluation Laboratories Inc
 Specimen Correlates with Drawing
 Deviations Noted - TEL # 01990817
 Date 10-31-13 Verified by *JW*

PRODUCT:		FLEETWOOD KONA 3800 CASEMENT WINDOW	
PART OR ASSEMBLY:		TEST ELEVATION	
NO.	DATE	REVISIONS	BY
DATE: 9/25/13			
SCALE: N.T.S.			
DWG. BY: JK			
CHK. BY: LFS			
DRAWING NO.:			
L-7032			
SHEET 2 OF 12			

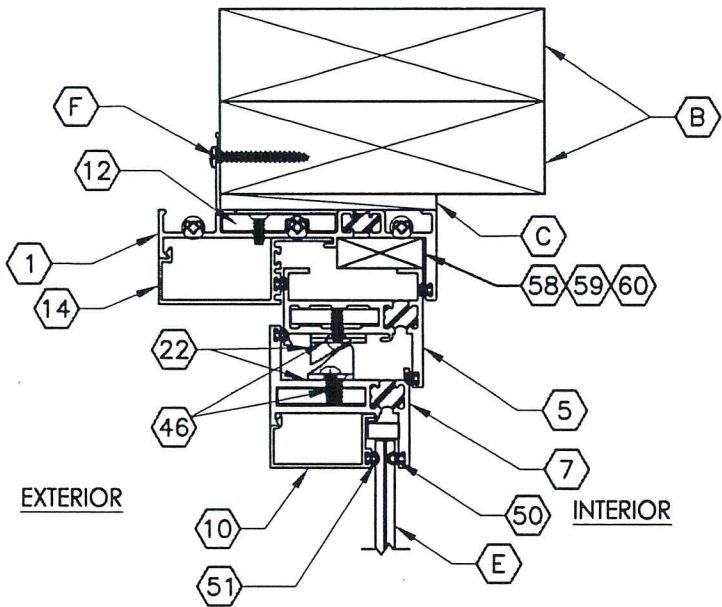

1 VERTICAL CROSS SECTION
3

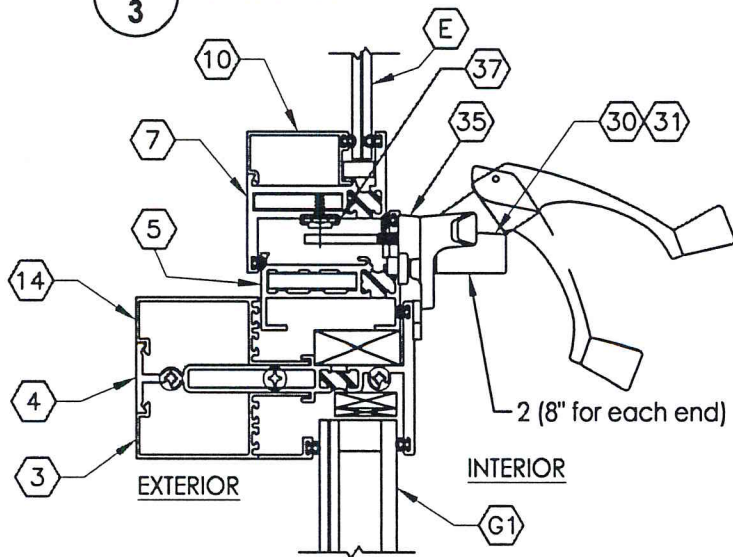

2 VERTICAL CROSS SECTION
3

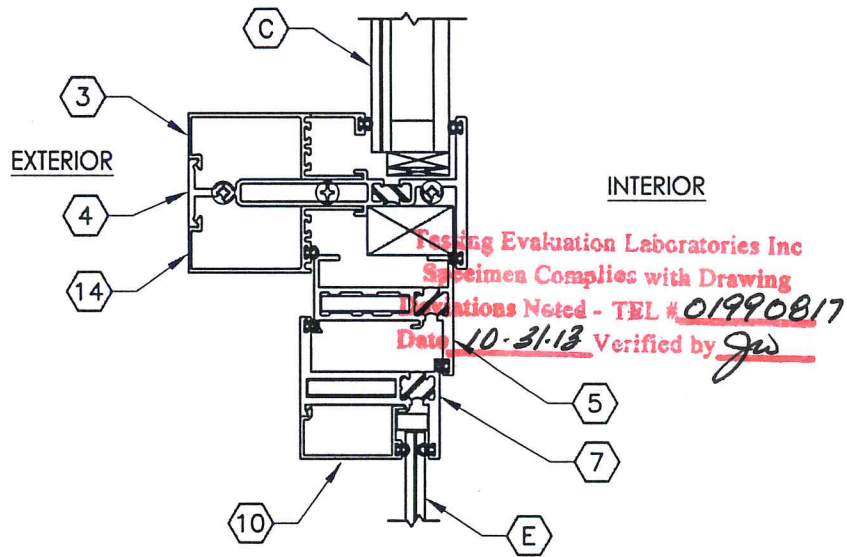

3 VERTICAL CROSS SECTION
3

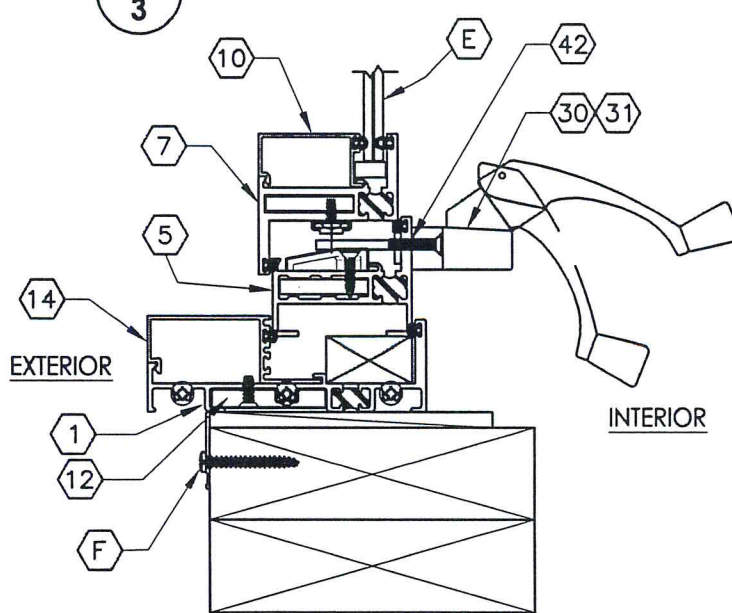

4 VERTICAL CROSS SECTION
3

PRODUCT:		FLEETWOOD KONA 3800 CASEMENT WINDOW	
PART OR ASSEMBLY:		VERTICAL CROSS SECTIONS	
NO.	DATE	BY	REVISIONS
DATE: 9/25/13			
SCALE: N.T.S.			
DWG. BY: JK			
CHK. BY: LFS			
DRAWING NO.: L-7032			
SHEET 3 OF 12			

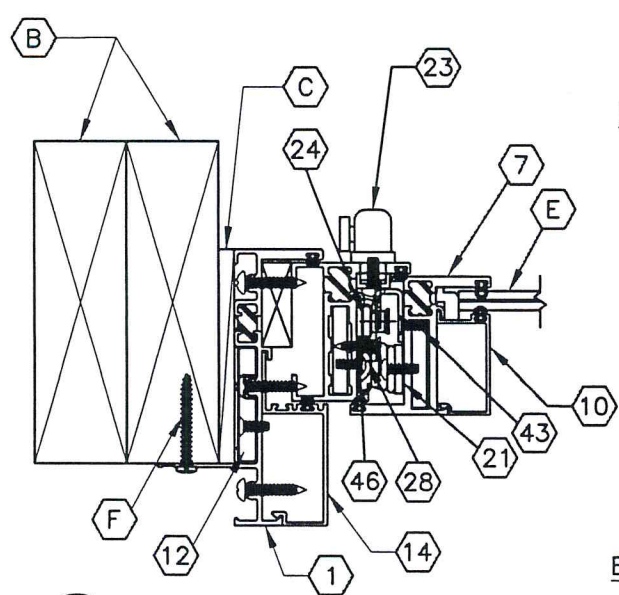

1
4 **HORIZONTAL CROSS SECTION**

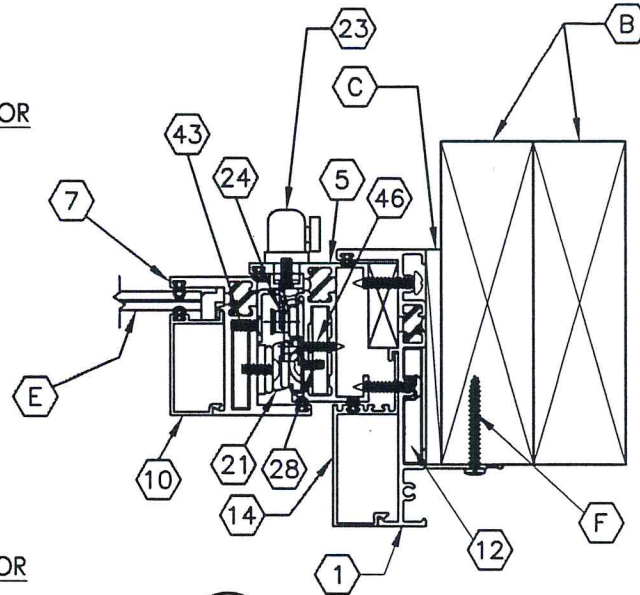

2
4 **HORIZONTAL CROSS SECTION**

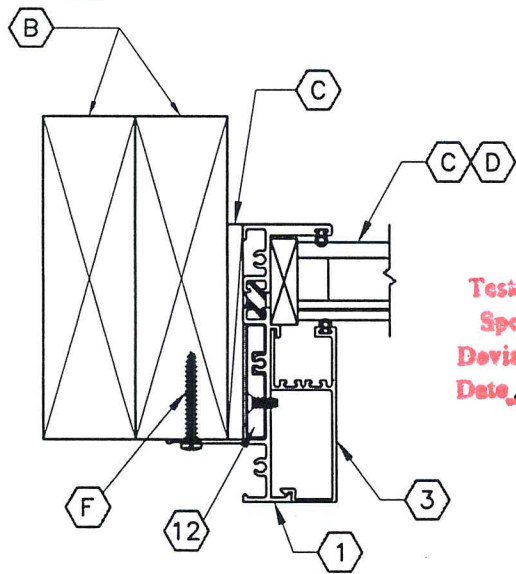

3
4 **HORIZONTAL CROSS SECTION**

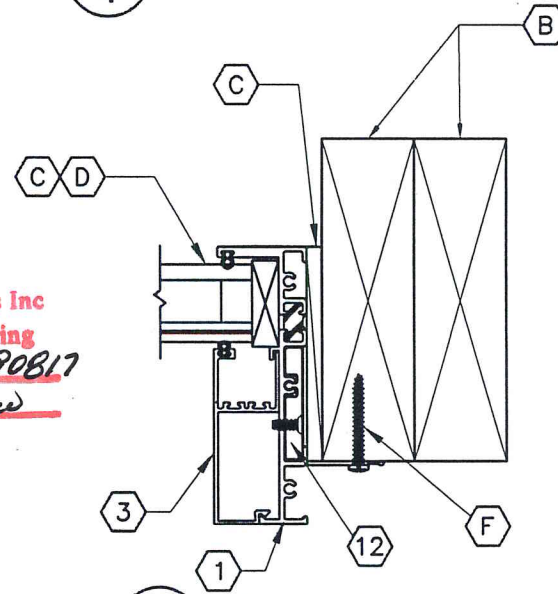

4
4 **HORIZONTAL CROSS SECTION**

Testing Evaluation Laboratories Inc
 Specimen Complies with Drawing
 Deviations Noted - TEL # 01990817
 Date 10.31.13 Verified by JW

PRODUCT: FLEETWOOD KONA 3800 CASEMENT WINDOW		PART OR ASSEMBLY: HORIZONTAL CROSS SECTIONS	
		NO.	DATE
R.W. BUILDING CONSULTANTS, INC. 813.659.9197			
DATE: 9/25/13			
SCALE: N.T.S.			
DWG. BY: JK			
CHK. BY: LFS			
DRAWING NO.: L-7032			
SHEET 4 OF 12			

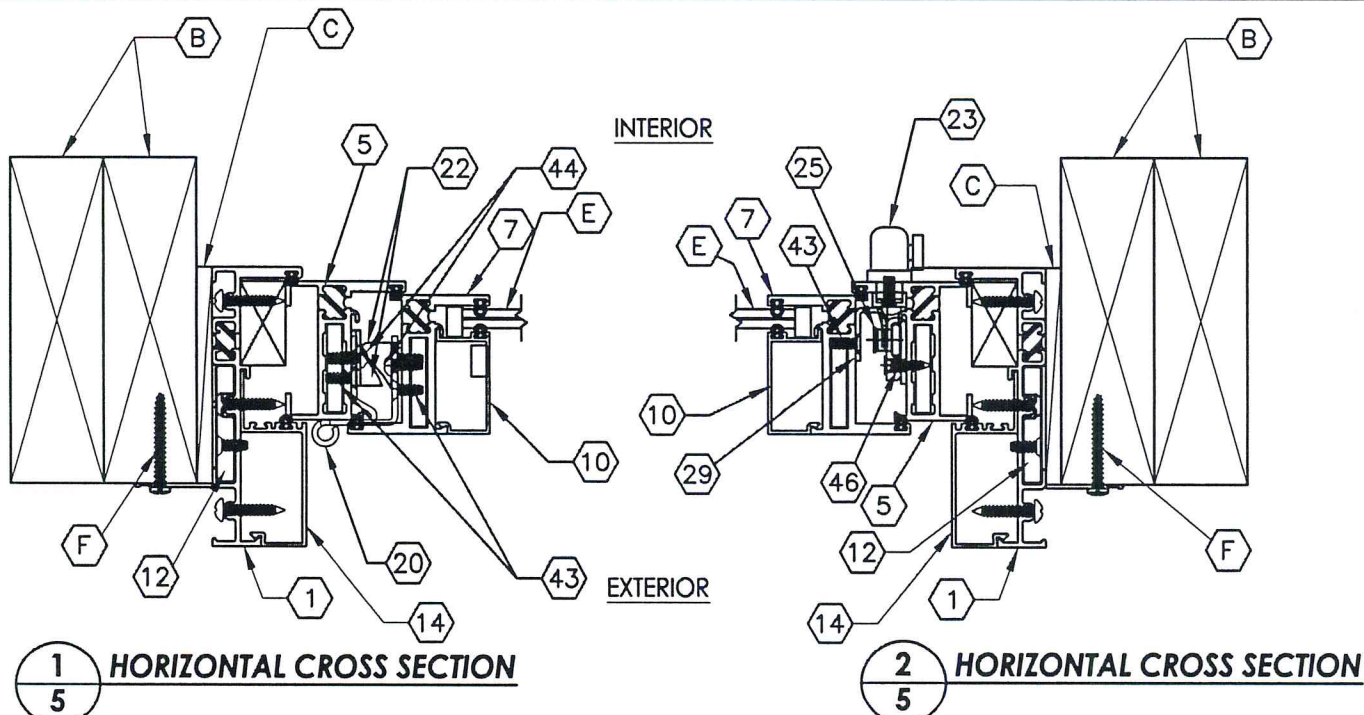

Testing Evaluation Laboratories Inc
 Specimen Complies with Drawing
 Deviation Noted - TEL # 01990817
 Date 10-31-13 Verified by ju

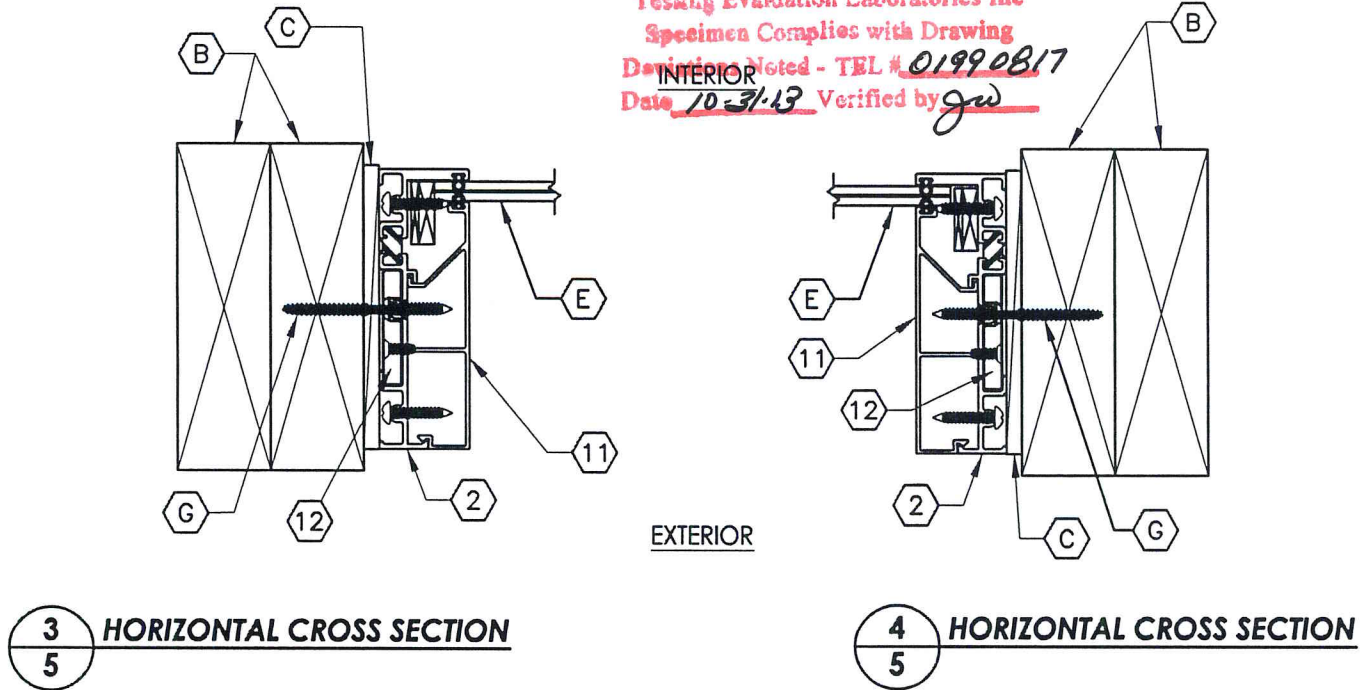

PRODUCT:		FLEETWOOD KONA 3800 CASEMENT WINDOW	
PART OR ASSEMBLY:		HORIZONTAL CROSS SECTIONS	
NO.	DATE	BY	REVISIONS
 RW BUILDING CONSULTANTS, INC. 813.659.9197			
DATE: 9/25/13			
SCALE: N.T.S.			
DWG. BY: JK			
CHK. BY: LFS			
DRAWING NO.:			
L-7032			
SHEET <u>5</u> OF <u>12</u>			

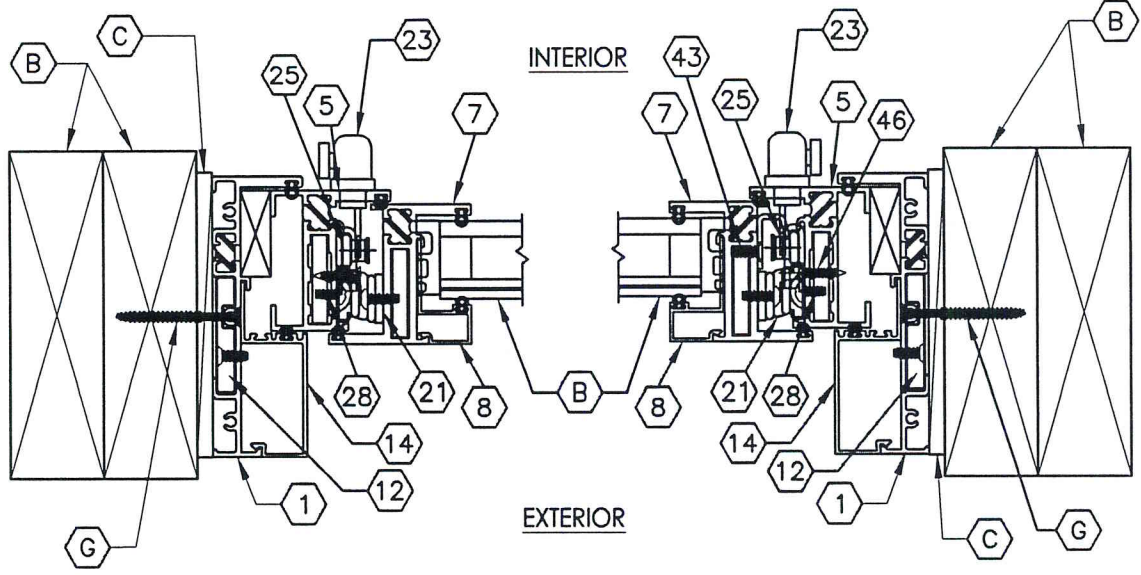

1
6 HORIZONTAL CROSS SECTION

2
6 HORIZONTAL CROSS SECTION

Testing Evaluation Laboratories Inc
 Specimen Complies with Drawing
 Deviations Noted - TEL # 01990817
 Date 10-31-13 Verified by gzw

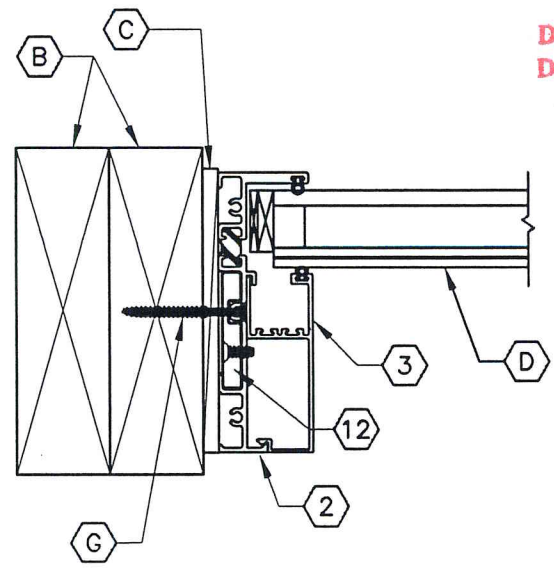

3
6 HORIZONTAL CROSS SECTION

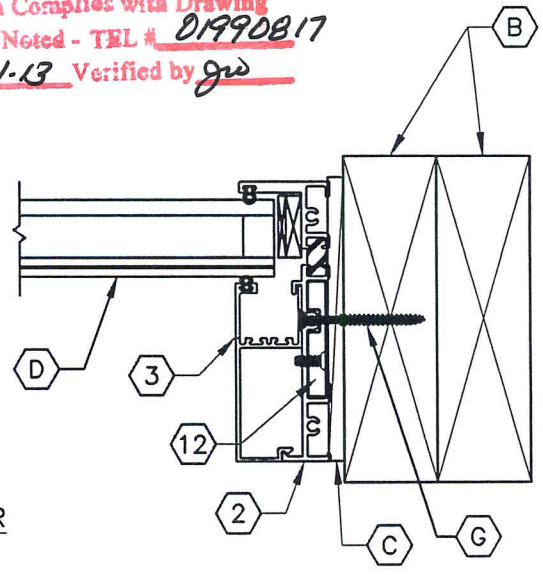

4
6 HORIZONTAL CROSS SECTION

PRODUCT: FLEETWOOD KONA 3800 CASEMENT WINDOW		PART OR ASSEMBLY: HORIZONTAL CROSS SECTIONS	
NO.	DATE	BY	REVISIONS
DATE: 9/25/13			
SCALE: N.T.S.			
DWG. BY: JK			
CHK. BY: LFS			
DRAWING NO.: L-7032			
SHEET <u>6</u> OF <u>12</u>			

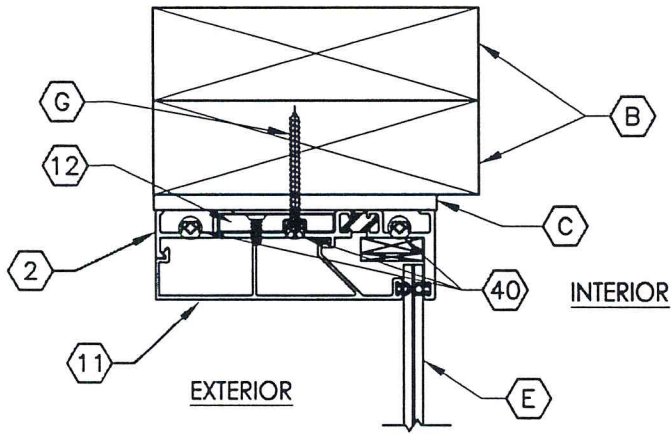

1
7 **VERTICAL CROSS SECTION**

Testing Evaluation Laboratories Inc
 Specimen Complies with Drawing
 Deviations Noted - TEL # 01990817
 Date 10-31-13 Verified by *JW*

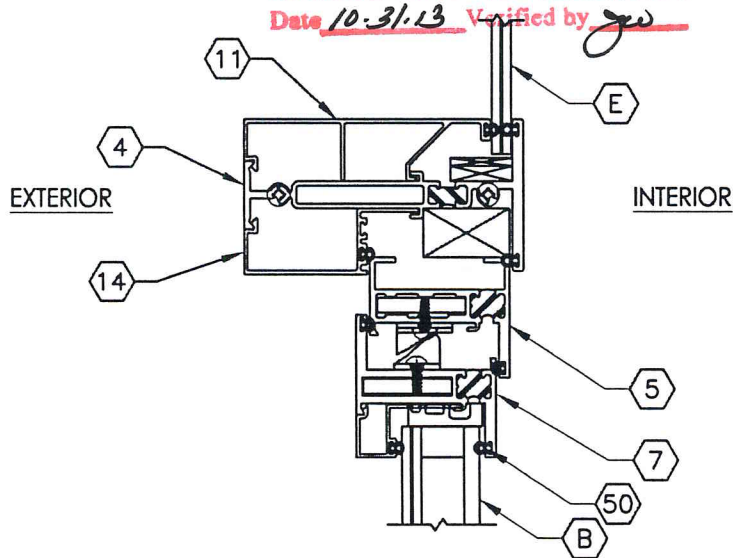

2
7 **VERTICAL CROSS SECTION**

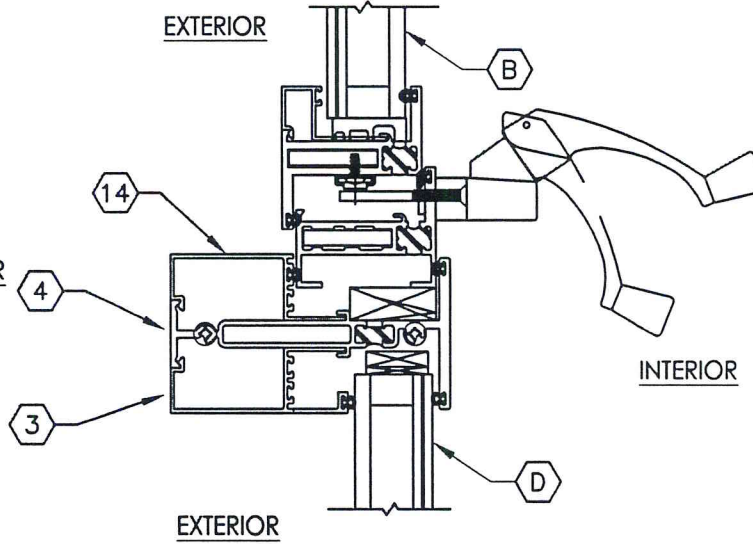

3
7 **VERTICAL CROSS SECTION**

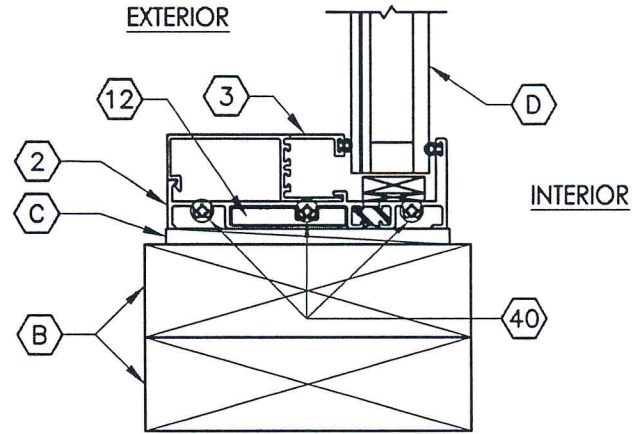

4
7 **VERTICAL CROSS SECTION**

PRODUCT:		FLEETWOOD KONA 3800 CASEMENT WINDOW	
PART OR ASSEMBLY:		VERTICAL CROSS SECTIONS	
NO.	DATE	BY	REVISIONS
DATE: 9/25/13			
SCALE: N.T.S.			
DWG. BY: JK			
CHK. BY: LFS			
DRAWING NO.:			
L-7032			
SHEET <u>7</u> OF <u>12</u>			

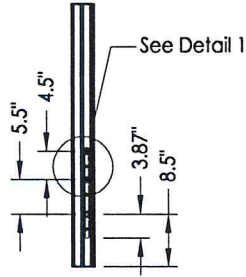
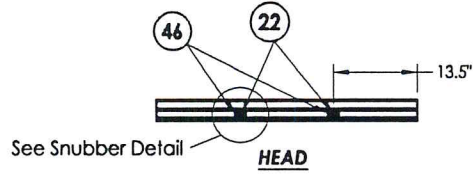

LOCK JAMB
Single Point Lock
(Jamb Sides Horizontal Awning)

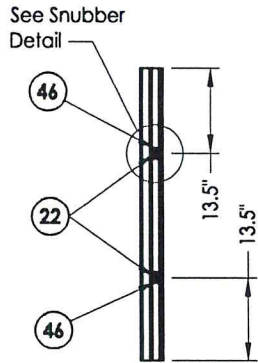
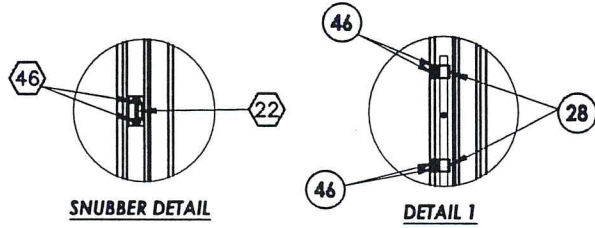

SNUBBER JAMB
(Casement)

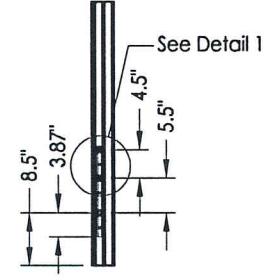
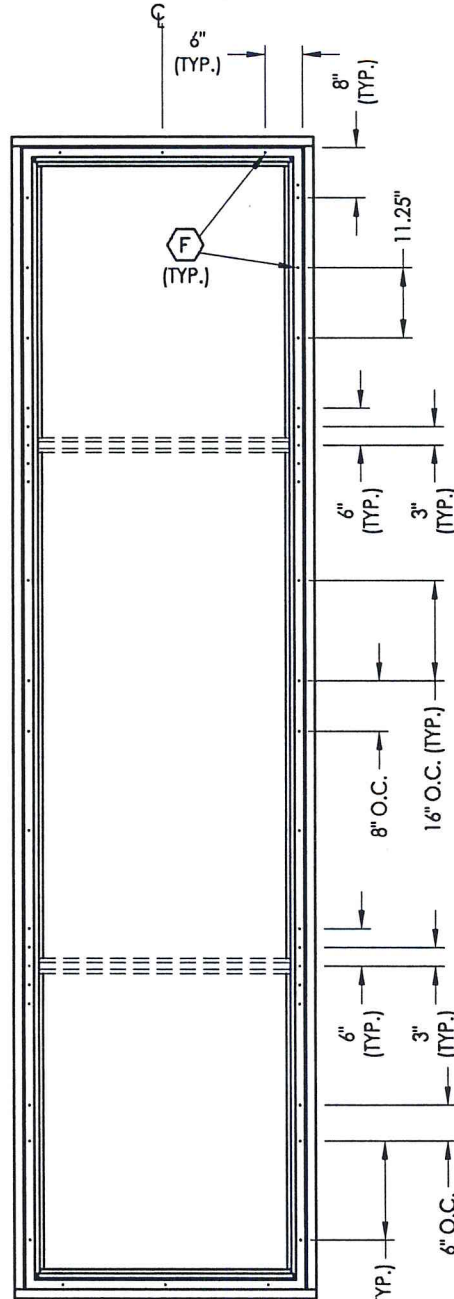

LOCK JAMB
Single Point Lock
(Jamb Sides Horizontal Awning)

Testing Evaluation Laboratories Inc
Specimen Complies with Drawing
Deviations Noted - TEL # 01990817
Date 10-31-13 Verified by JW

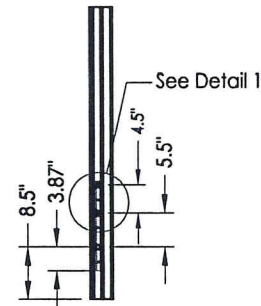

LOCK JAMB
Two Point Lock
(Casement)

PRODUCT:		FLEETWOOD KONA 3800 CASEMENT WINDOW	
PART OR ASSEMBLY:		FRAME ANCHORING	
NO.	DATE	REVISIONS	BY
DATE: 9/25/13			
SCALE: N.T.S.			
DWG. BY: JK			
CHK. BY: LFS			
DRAWING NO.: L-7032			
SHEET 8 OF 12			

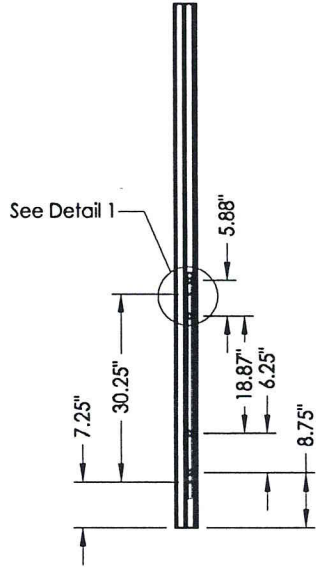
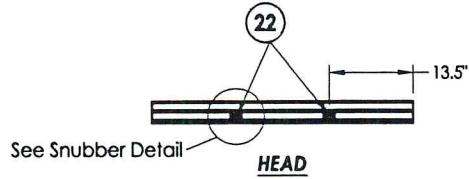

LOCK JAMB
Two Point Lock
(Casement)

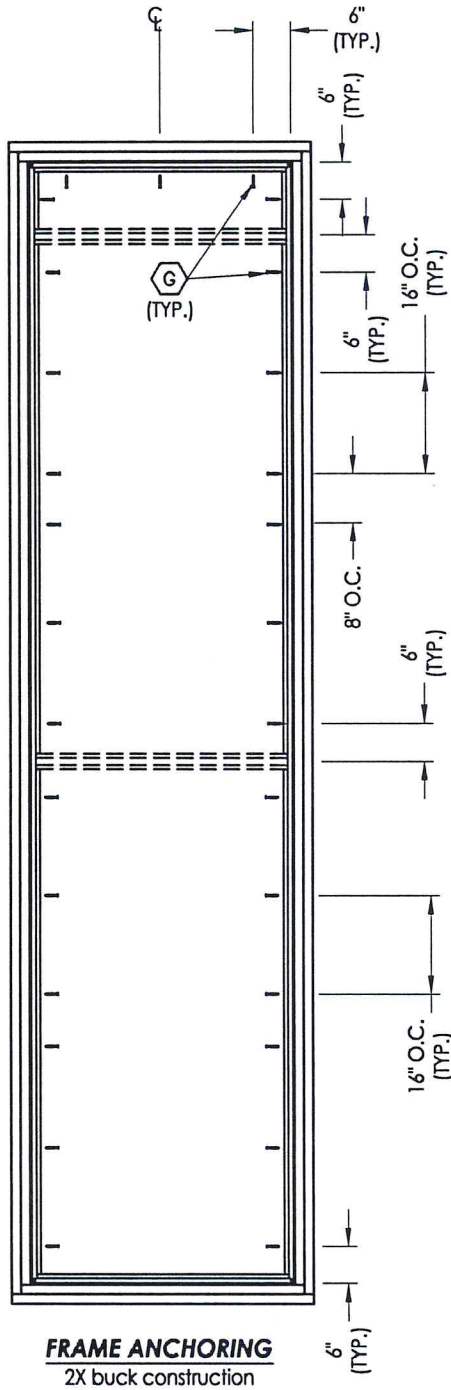
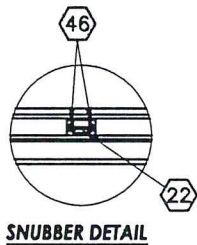

Testing Evaluation Laboratories Inc
Specimen Complies with Drawing
Deviations Noted - TEL # 01990817
Date 10.31.13 Verified by *gw*

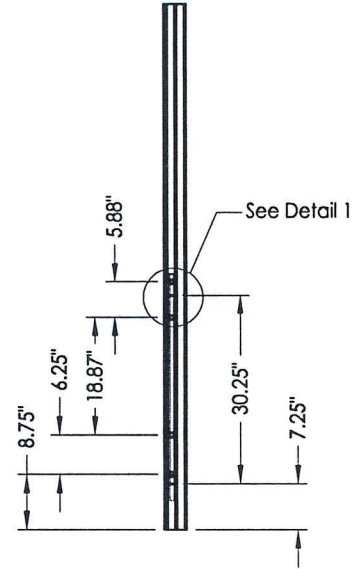

LOCK JAMB
Two Point Lock
(Casement)

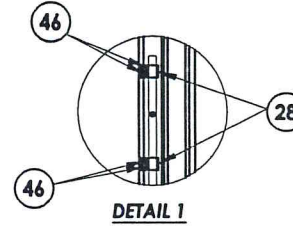

PRODUCT:		FLEETWOOD KONA 3800 CASEMENT WINDOW	
PART OR ASSEMBLY:		FRAME ANCHORING	
NO.	DATE	REVISIONS	BY
 RW BUILDING CONSULTANTS, INC. 813.659.9197			
DATE: 9/25/13			
SCALE: N.T.S.			
DWG. BY: JK			
CHK. BY: LFS			
DRAWING NO.: L-7032			
SHEET 9 OF 12			

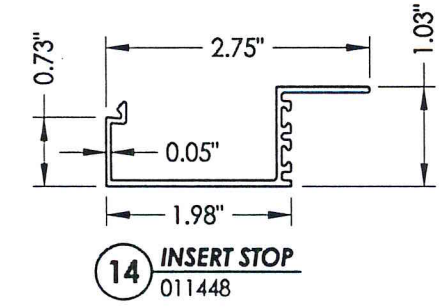

14 INSERT STOP
011448

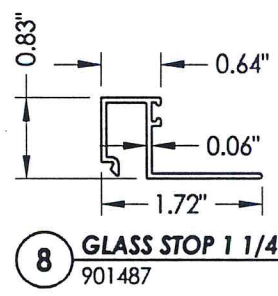

8 GLASS STOP 1 1/4"
901487

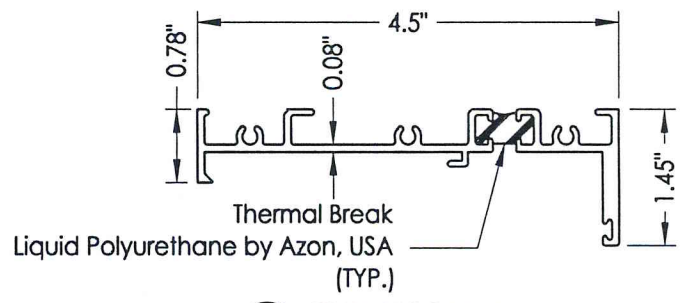

2 KONA BLOCK FRAME
011239

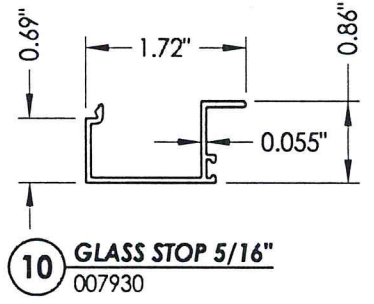

10 GLASS STOP 5/16"
007930

Testing Evaluation Laboratories Inc
Specimen Complies with Drawing
Deviations Noted - TEL # 01990817
Date 10.31.13 Verified by *JD*

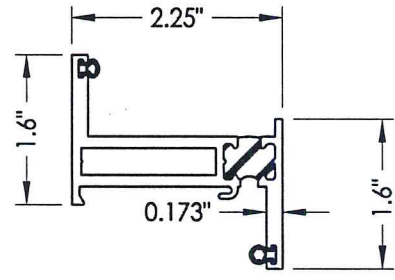

7 ZEE BAR (PANEL)
H006733

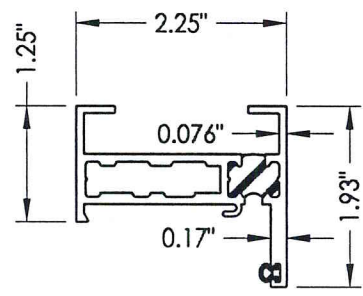

5 BLOCK FRAME
5278C1

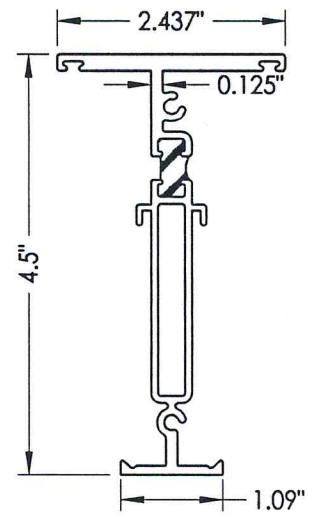

4 MULLION
H011241

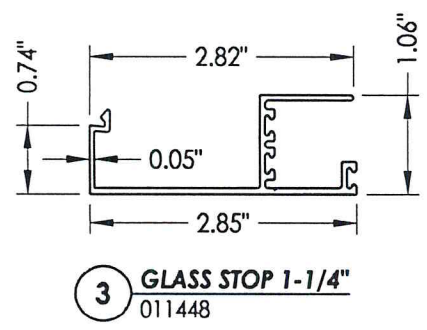

3 GLASS STOP 1-1/4"
011448

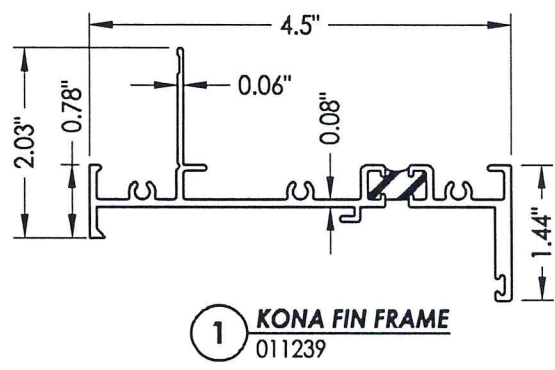

1 KONA FIN FRAME
011239

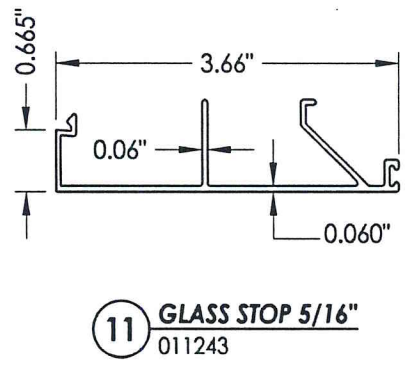

11 GLASS STOP 5/16"
011243

PRODUCT:		FLEETWOOD KONA 3800 CASEMENT WINDOW	
PART OR ASSEMBLY:		COMPONENTS	
NO.	DATE	REVISIONS	BY
DATE: 9/25/13			
SCALE: N.T.S.			
DWG. BY: JK			
CHK. BY: LFS			
DRAWING NO.: L-7032			
SHEET 10 of 12			

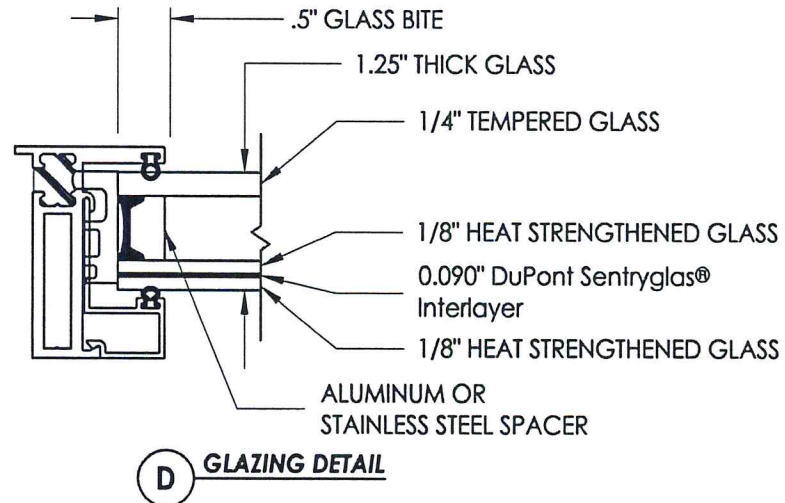
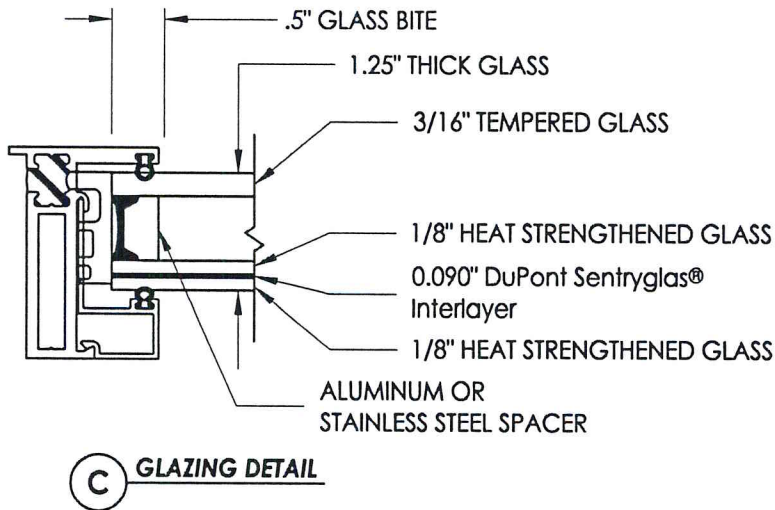
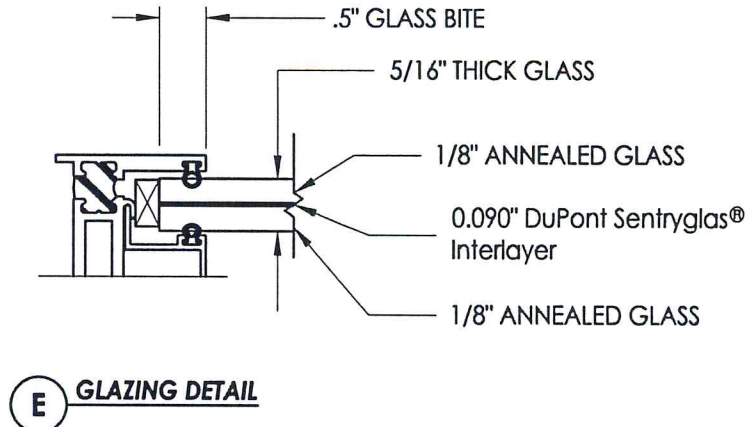
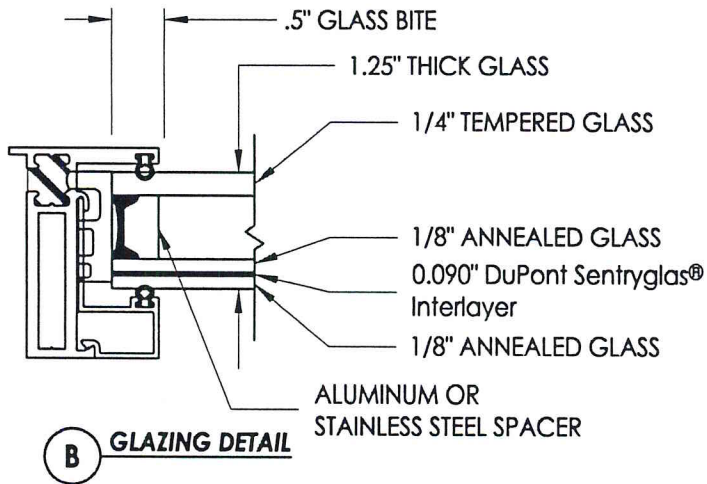

Testing Evaluation Laboratories Inc
 Specimen Complies with Drawing
 Deviations Noted - TEL # 01990817
 Date 10.31.13 Verified by *gzw*

PRODUCT:		FLEETWOOD KONA 3800 CASEMENT WINDOW	
PART OR ASSEMBLY:		GLAZING DETAILS	
NO.	DATE	REVISIONS	BY
DATE: 9/25/13			
SCALE: N.T.S.			
DWG. BY: JK			
CHK. BY: LFS			
DRAWING NO.: L-7032			
SHEET 11 OF 12			

BILL OF MATERIALS		
ITEM #	DESCRIPTION	MATERIAL
B	2X BUCK SG >= 0.55	WOOD
C	1/4" MAX. SHIM SPACE	-
F	#10 x 1-1/2" PFH WOOD SCREW	STEEL
G	#10 x 2" PFH WOOD SCREW	STEEL
1	KONA FIN FRAME	6063-T6 ALUM
2	KONA BLOCK FRAME	6063-T6 ALUM
3	GLASS STOP 1 1/4"	6063-T6 ALUM
4	MULLION	6063-T6 ALUM
5	WESTWOOD BLOCK FRAME	6063-T6 ALUM
7	WESTWOOD ZEE BAR (PANEL)	6063-T6 ALUM
8	GLASS STOP 1 1/4"	6063-T6 ALUM
10	GLASS STOP 1/2"	6063-T6 ALUM
11	GLASS STOP 5/8"	6063-T6 ALUM
12	SHEAR BLOCK	ALUM
13	CORNER KEY	ALUM
14	INSERT STOP	ALUM
20	SS. BUTT HINGE	SS
21	4 BAR HINGE	SS
22	SNUBBER-COMMERCIAL PULL-IN BLOCK	ZINC ALLOY
23	MULTIPOINT LOCK HANDLE	SS
24	SINGLE POINT LOCKING BAR	SS
25	2 POINTS LOCKING BAR	SS
28	TIE BAR GUIDE	PLASTIC
29	KEEPER	SS
30	CASEMENT ROTOR GEAR 13.5"	SS
35	CAM HANDLE / STRIKE PLATE	SS
36	CASEMENT SS. TRACK	SS
37	AWNING SS. TRACK	SS
40	#10 X 1" PPH SMS	STEEL
42	MACHINE SCREW NO 10-32, FHP .75"	STEEL
43	SCREW NO 10 , UFHP .5"	STEEL
44	SCREW NO 8, PHP, .50"	STEEL

46	SCREW NO 8, FHP, .750"	STEEL
47	MACHINE SCREW NO 10-32, PHP .5"	STEEL
48	BACK UP NUTS	STEEL
50	BULB VINYL (EPDM 70 DUROMETER)-TREMCO	-
51	MINI BULB VINYL(EPDM 70 DUROMETER)-TREMCO	-
52	WOOD BLOCK .750" X 1.250"	-
53	ALUMINUM BLOCK .750" X 1.250"	-
54	PVC BLOCK .750" X 1.250"	-
55	SETTING BLOCK	-
56	SETTING BLOCK 4" x 1/4" x 1"	-
57	PIVOT SHIM	-
58	WOOD BLOCK .50" X 1.250"	-
59	ALUMINUM BLOCK .50" X 1.250"	-
60	PVC BLOCK .50" X 1.250"	-
61	SETTING BLOCK 4" x 1/8" x 1"	-

Testing Evaluation Laboratories Inc
 Specimen Corrupts with Drawing
 Deviations Noted - TEL # 01990817
 Date 10.31.13 Verified by gaw

PRODUCT:		FLEETWOOD KONA 3800 CASEMENT WINDOW	
PART OR ASSEMBLY:		BILL OF MATERIALS	
NO.	DATE	BY	REVISIONS
			
DATE: 9/25/13			
SCALE: N.T.S.			
DWG. BY: JK			
CHK. BY: LFS			
DRAWING NO.:			
L-7032			
SHEET <u>12</u> OF <u>12</u>			

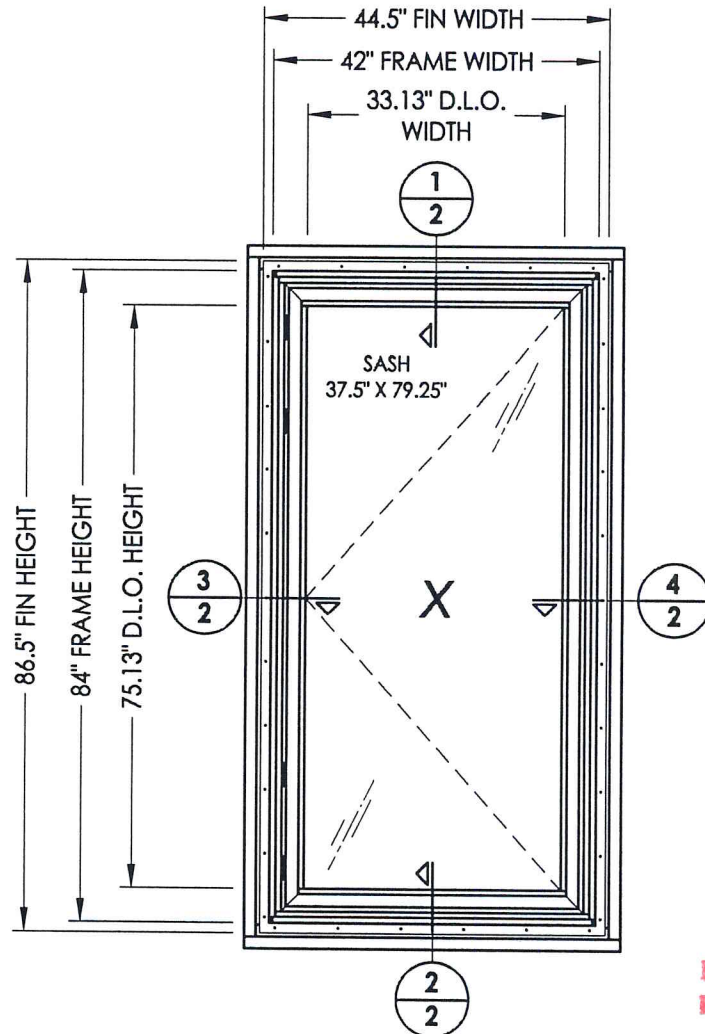

SPEC# 2, 2A GLASS TYPE A
SPEC# 5, 5A GLASS TYPE G

Testing Evaluation Laboratories Inc
 Specimen Complies with Drawing
 Deviations Noted - TEL # 01990817
 Date 10-31-13 Verified by ju

TABLE OF CONTENTS	
SHEET #	DESCRIPTION
1	Table of contents and test elevation
2	Horizontal and vertical cross sections
3	Frame anchoring
4	Components and glazing details
5	Bill of materials

PRODUCT:		FLEETWOOD KONA 3800 CASEMENT WINDOW	
PART OR ASSEMBLY:		TABLE OF CONTENTS AND TEST ELEVATION	
NO.	DATE	REVISIONS	BY
DATE: 9/25/13			
SCALE: N.T.S.			
DWG. BY: JK			
CHK. BY: LFS			
DRAWING NO.: L-7032A			
SHEET <u>1</u> OF <u>5</u>			

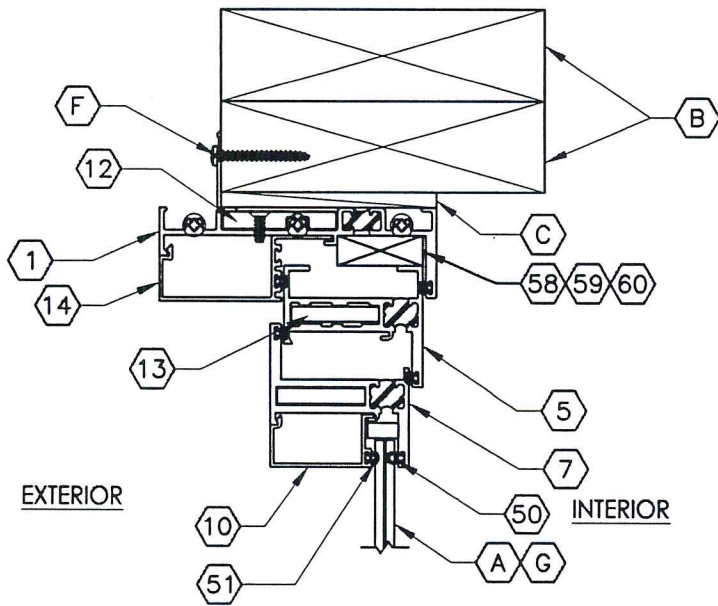

1
2 VERTICAL CROSS SECTION

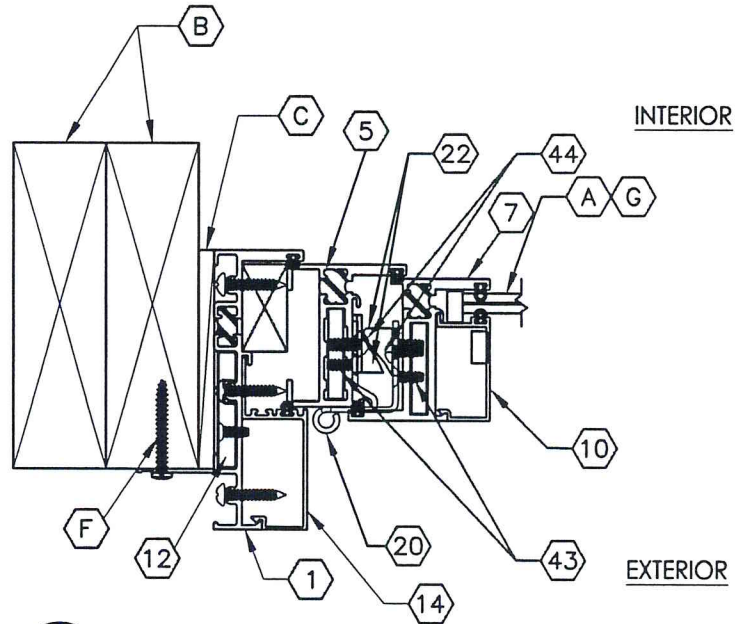

3
2 HORIZONTAL CROSS SECTION

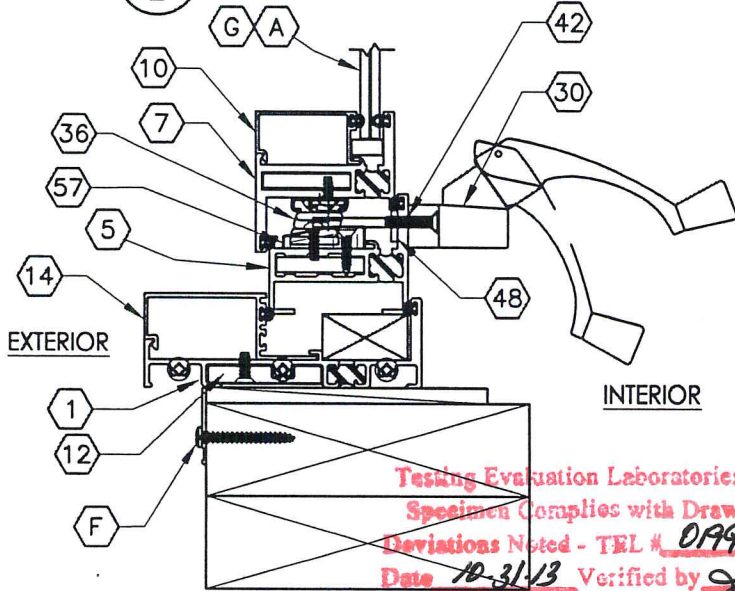

2
2 VERTICAL CROSS SECTION

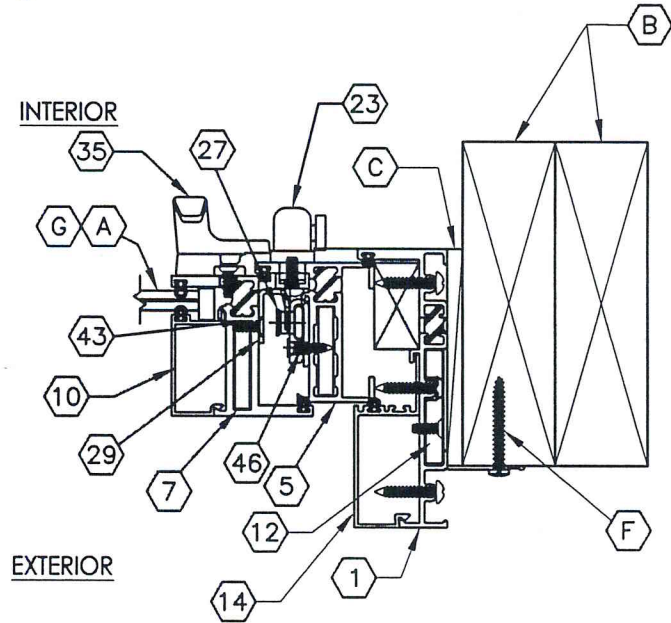

4
2 HORIZONTAL CROSS SECTION

Testing Evaluation Laboratories Inc
 Specimen Complies with Drawing
 Deviations Noted - TEL # 01990817
 Date 10-31-13 Verified by *gn*

PRODUCT: FLEETWOOD KONA 3800 CASEMENT WINDOW		PART OR ASSEMBLY: HORIZONTAL AND VERTICAL CROSS SECTIONS	
NO.	DATE	BY	REVISIONS
 RW BUILDING CONSULTANTS, INC. 813.659.9197			
DATE: 9/25/13			
SCALE: N.T.S.			
DWG. BY: JK			
CHK. BY: LFS			
DRAWING NO.: L-7032A			
SHEET 2 OF 5			

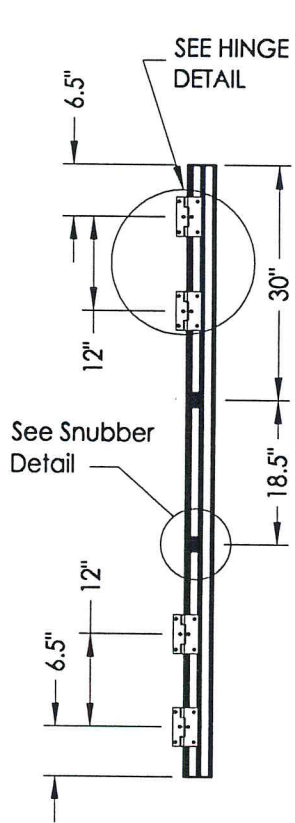

HINGE JAMB

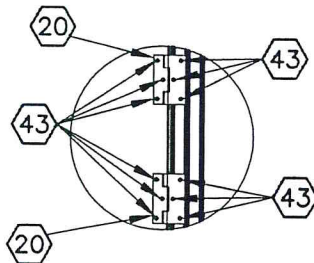

HINGE DETAIL

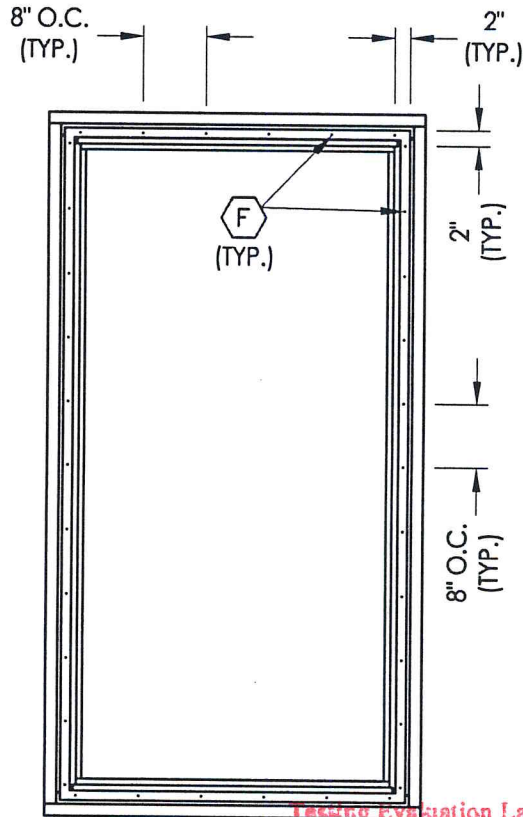

FRAME ANCHORING
2X buck construction

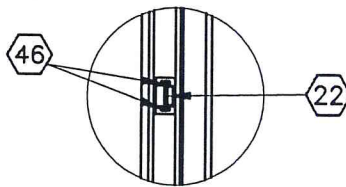

SNUBBER DETAIL

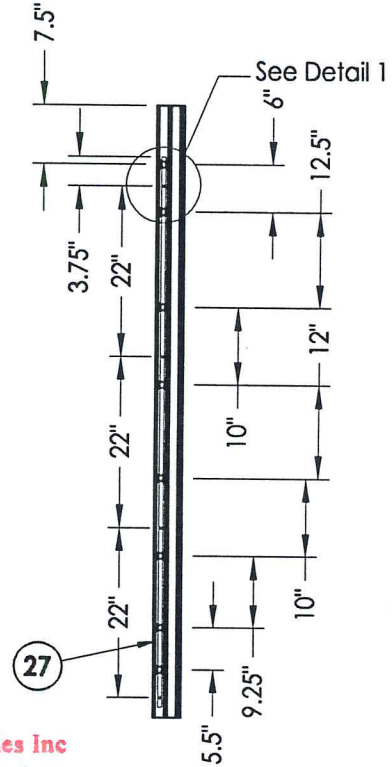

LOCK JAMB
Locking Points (4)

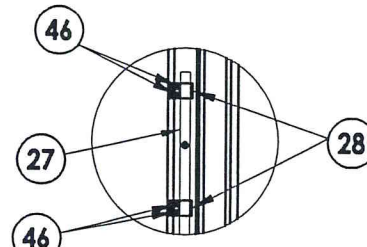

DETAIL 1

Testing Evaluation Laboratories Inc
Specimen Complies with Drawing
Deviations Noted - TEL # 01990817
4/8/13 Verified by *gw*

PRODUCT:		FLEETWOOD KONA 3800 CASEMENT WINDOW	
PART OR ASSEMBLY:		FRAME ANCHORING	
NO.	DATE	REVISIONS	BY
DATE: 9/25/13			
SCALE: N.T.S.			
DWG. BY: JK			
CHK. BY: LFS			
DRAWING NO.: L-7032A			
SHEET 3 OF 5			

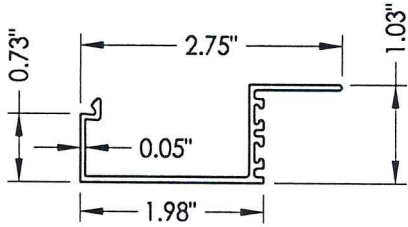

14 INSERT STOP
011448

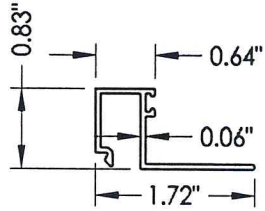

8 GLASS STOP 1-1/4"
901487

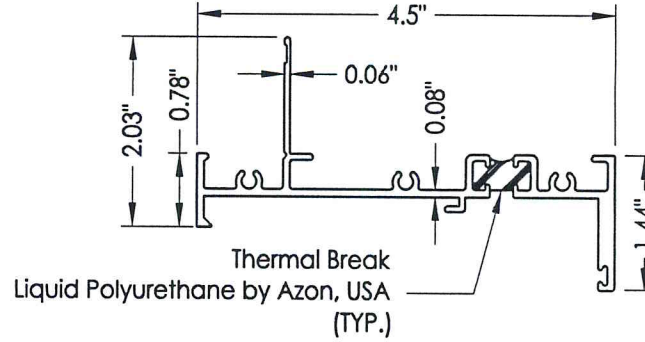

Thermal Break
Liquid Polyurethane by Azon, USA
(TYP.)

Testing Evaluation Laboratories Inc
Specimen Complies with Drawing
Deviations Noted - TEL # 01990817
Date 10.31.13 Verified by Jew

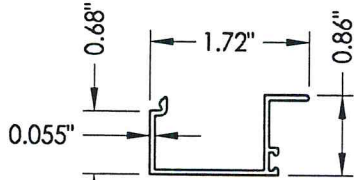

10 GLASS STOP 9/16"
007930

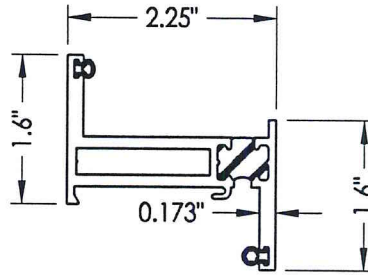

7 ZEE BAR (PANEL)
H006733

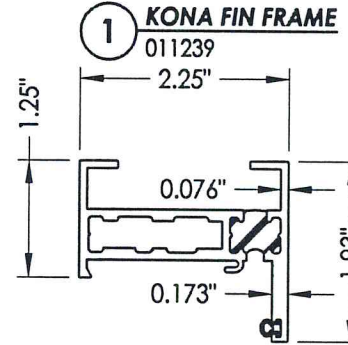

1 KONA FIN FRAME
011239

5 BLOCK FRAME
5278C1

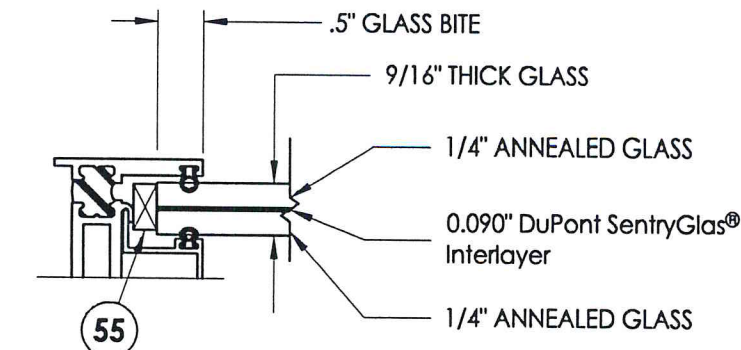

G GLAZING DETAIL
Spec #5, 5A

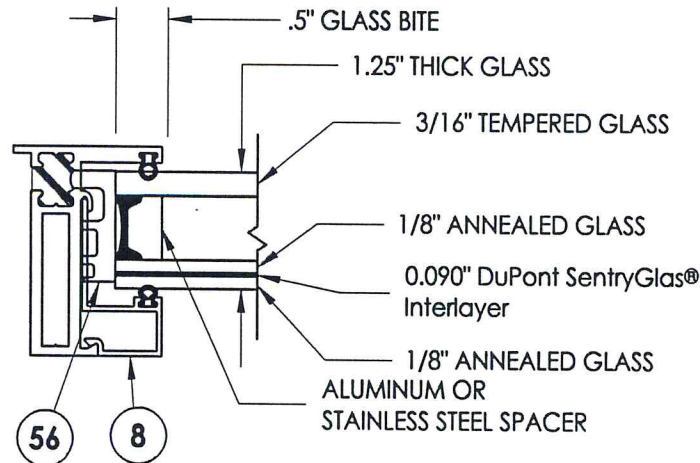

A GLAZING DETAIL
Spec. #2, 2A

PRODUCT:		FLEETWOOD KONA 3800 CASEMENT WINDOW	
PART OR ASSEMBLY:		COMPONENTS AND GLAZING DETAILS	
NO.	DATE	REVISIONS	BY
DATE: 9/25/13			
SCALE: N.T.S.			
DWG. BY: JK			
CHK. BY: LFS			
DRAWING NO.:			
L-7032A			
SHEET <u>4</u> OF <u>5</u>			

BILL OF MATERIALS		
ITEM #	DESCRIPTION	MATERIAL
B	2X BUCK SG >= 0.55	WOOD
C	1/4" MAX. SHIM SPACE	-
F	#10 x 1-1/2" PPH WOOD SCREW	STEEL
G	#10 x 2" PFH WOOD SCREW	STEEL
1	KONA FIN FRAME	6063-T6 ALUM
5	WESTWOOD BLOCK FRAME	6063-T6 ALUM
7	WESTWOOD ZEE BAR (PANEL)	6063-T6 ALUM
8	GLASS STOP 1 1/4"	6063-T6 ALUM
10	GLASS STOP 1/2"	6063-T6 ALUM
12	SHEAR BLOCK	ALUM
13	CORNER KEY	ALUM
14	INSERT STOP	ALUM
20	SS. BUTT HINGE	SS
22	SNUBBER-COMMERCIAL PULL-IN BLOCK	SS
23	MULTIPOINT LOCK HANDLE	SS
27	4 POINTS LOCKING BAR	SS
28	TIE BAR GUIDE	PLASTIC
29	KEEPER	SS
30	CASEMENT ROTOR GEAR 13.5"	SS
35	CAM HANDLE / STRIKE PLATE	SS
36	CASEMENT SS. TRACK	SS
42	MACHINE SCREW NO 10-32, FHP .75"	STEEL
43	SCREW NO 10, UFHP .5"	STEEL
44	SCREW NO 8, PHP, .50"	STEEL
46	SCREW NO 8, FHP, .750"	STEEL
48	BACK UP NUTS	STEEL
50	BULB VINYL (EPDM 70 DUROMETER)-TREMCO	-
51	MINI BULB VINYL(EPDM 70 DUROMETER)-TREMCO	-
55	SETTING BLOCK	-

56	SETTING BLOCK 4" x 1/4" x 1"	-
57	PIVOT SHIM	-
58	WOOD BLOCK .50" X 1.250"	-
59	ALUMINUM BLOCK .50" X 1.250"	-
60	PVC BLOCK .50" X 1.250"	-

Testing Evaluation Laboratories Inc
 Specimen Complies with Drawing
 Deviations Noted - TEL # 01990817
 Date 10-31-13 Verified by gzw

PRODUCT: FLEETWOOD KONA 3800 CASEMENT WINDOW		PART OR ASSEMBLY: BILL OF MATERIALS	
NO.	DATE	BY	REVISIONS
			
DATE: 9/25/13			
SCALE: N.T.S.			
DWG. BY: JK			
CHK. BY: LFS			
DRAWING NO.: L-7032A			
SHEET <u>5</u> OF <u>5</u>			

TABLE OF CONTENTS	
SHEET #	DESCRIPTION
1	Table of contents
2	Test elevation
3	Horizontal and vertical cross sections
4	Horizontal and vertical cross sections
5	Frame anchoring
6	Frame anchoring
7	Components
8	Glazing details
9	Bill of materials

Testing Evaluation Laboratories Inc
 Specimen Complies with Drawing
 Deviations Noted - TEL # 01990817
 Date ~~10-13-11~~ 10-31-13 Verified by JW



DATE: 9/25/13
 SCALE: N.T.S.
 DWG. BY: JK
 CHK. BY: LFS
 DRAWING NO.: L-7033
 SHEET 1 OF 9

PRODUCT: FLEETWOOD
 KONA 3800 CASEMENT WINDOW
 PART OR ASSEMBLY: TABLE OF CONTENTS

NO.	DATE	BY	REVISIONS

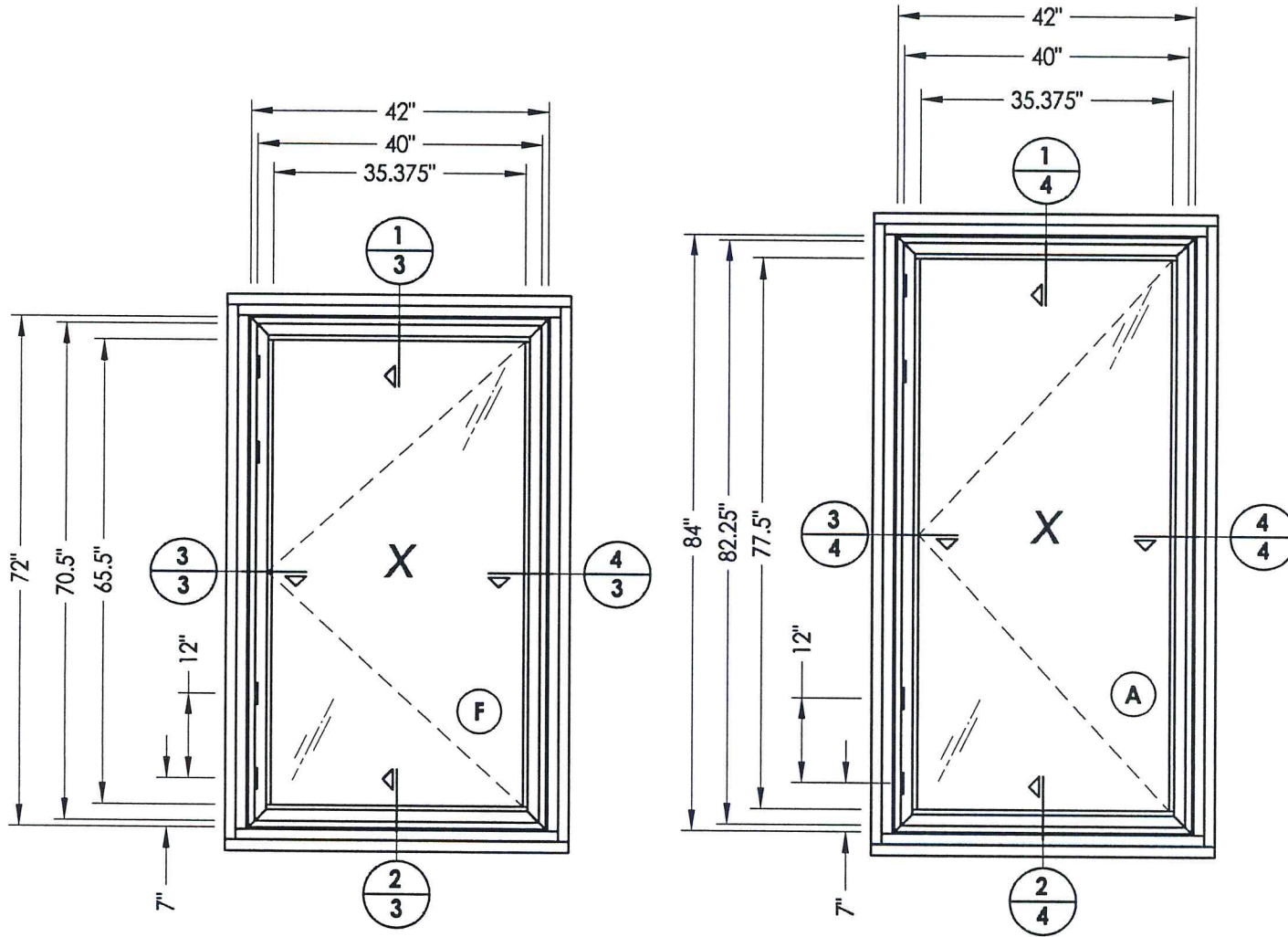

SPEC# 12, 12A

SPEC# 6, 6A

Testing Evaluation Laboratories Inc
 Specimen Complies with Drawing
 Deviations Noted - TEL # 01990817
 Date 10-31-13 Verified by JW

PRODUCT:		FLEETWOOD KONA 3800 CASEMENT WINDOW	
PART OR ASSEMBLY:		TEST ELEVATION	
NO.	DATE	REVISIONS	BY
DATE: 9/25/13			
SCALE: N.T.S.			
DWG. BY: JK			
CHK. BY: LFS			
DRAWING NO.: L-7033			
SHEET <u>2</u> OF <u>9</u>			

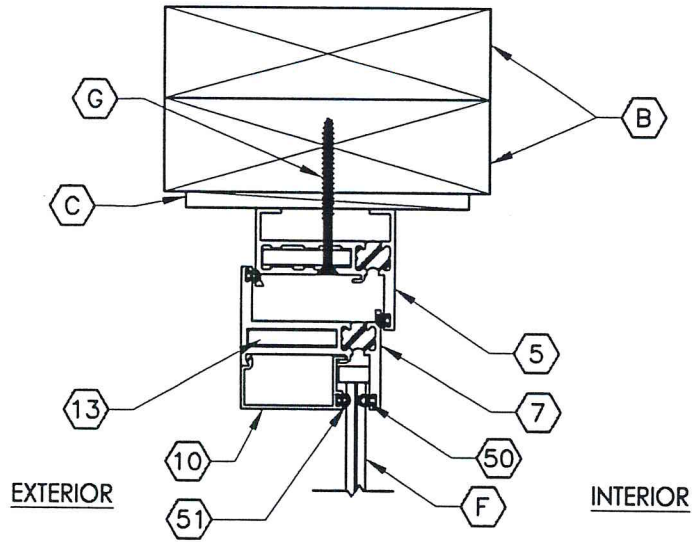

1
3 **VERTICAL CROSS SECTION**

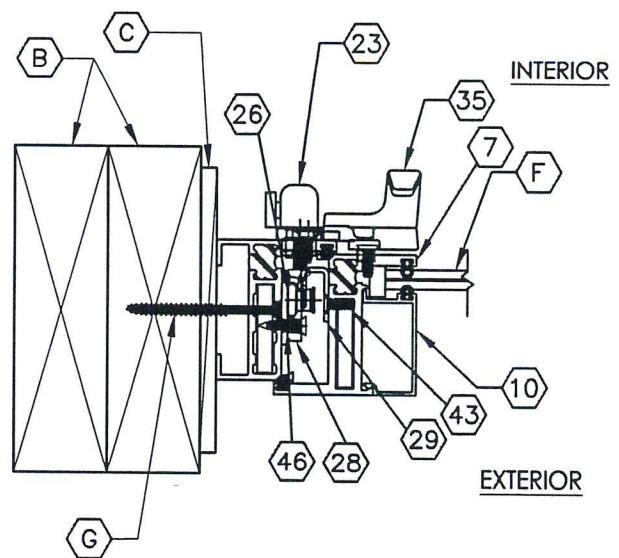

3
3 **HORIZONTAL CROSS SECTION**

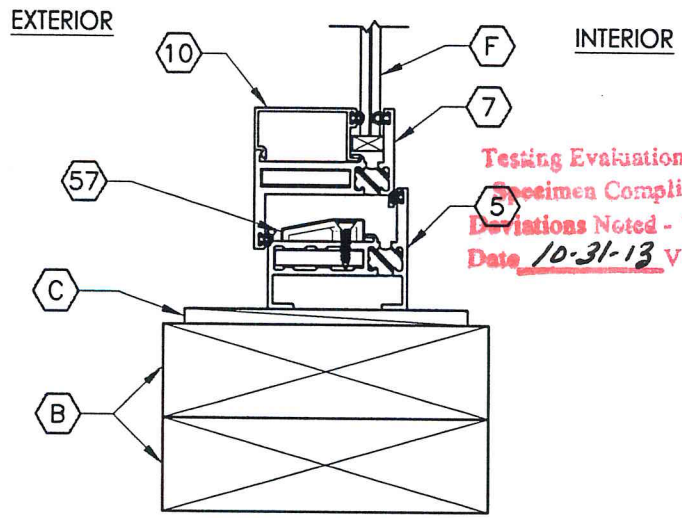

2
3 **VERTICAL CROSS SECTION**

Testing Evaluation Laboratories Inc
 Specimen Complies with Drawing
 Deviations Noted - TEL # 01990817
 Date 10-31-13 Verified by JW

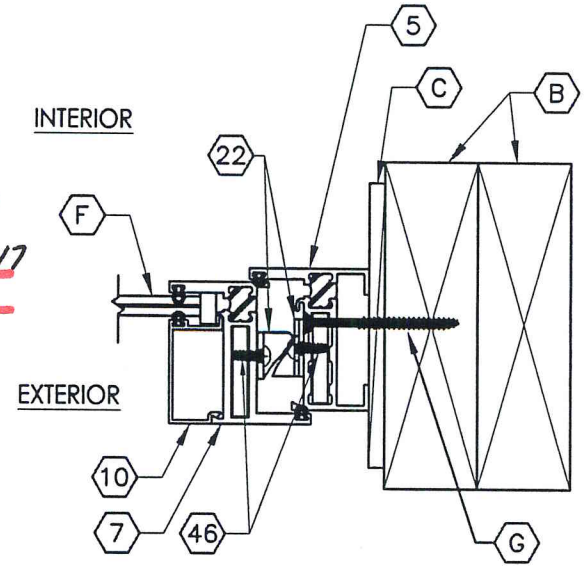

4
3 **HORIZONTAL CROSS SECTION**

PRODUCT:		FLEETWOOD KONA 3800 CASEMENT WINDOW	
PART OR ASSEMBLY:		HORIZONTAL AND VERTICAL CROSS SECTIONS	
NO.	DATE	REVISIONS	BY
RW BUILDING CONSULTANTS, INC. 813.659.9197			
DATE: 9/25/13			
SCALE: N.T.S.			
DWG. BY: JK			
CHK. BY: LFS			
DRAWING NO.: L-7033			
SHEET 3 OF 9			

Testing Evaluation Laboratories Inc
 Specimen Complies with Drawing
 Deviations Noted - TEL # 01990817
 Date 10-31-13 Verified by *gaw*

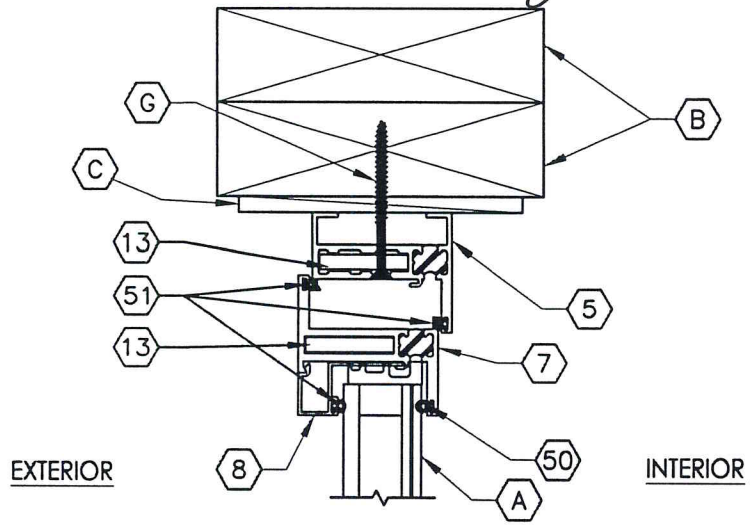

1
4 **VERTICAL CROSS SECTION**

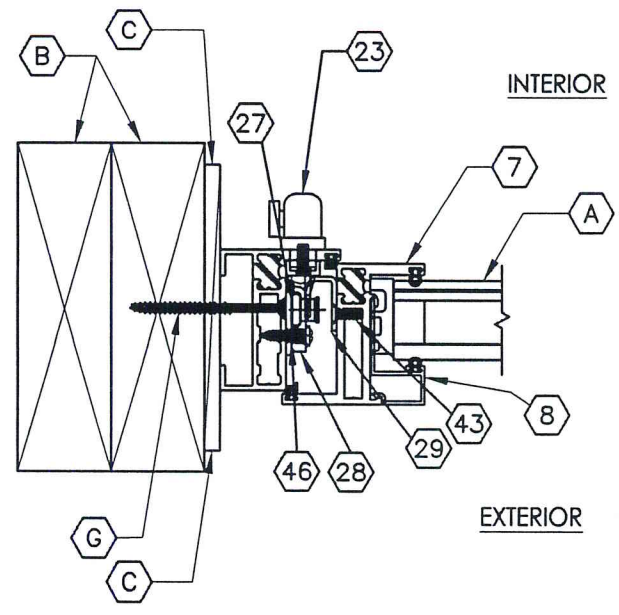

3
4 **HORIZONTAL CROSS SECTION**

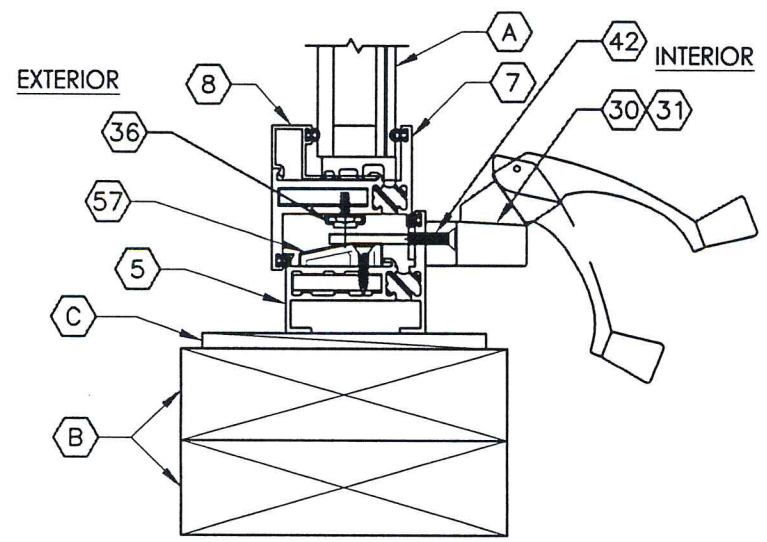

2
4 **VERTICAL CROSS SECTION**

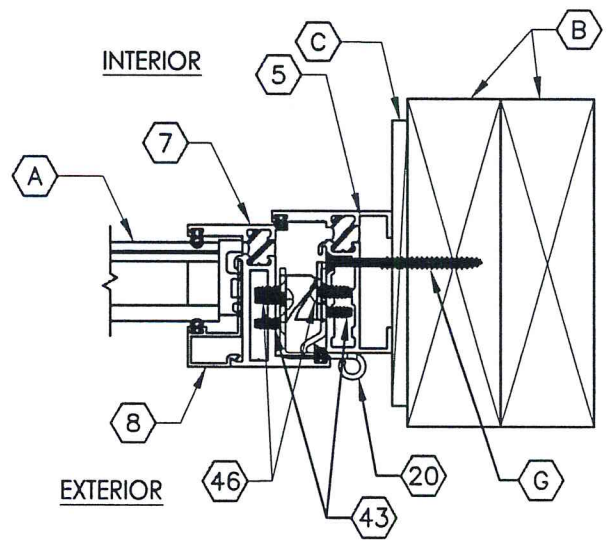

4
4 **HORIZONTAL CROSS SECTION**

PRODUCT:		FLEETWOOD KONA 3800 CASEMENT WINDOW	
PART OR ASSEMBLY:		HORIZONTAL AND VERTICAL CROSS SECTIONS	
NO.	DATE	REVISIONS	BY
			
DATE: 9/25/13			
SCALE: N.T.S.			
DWG. BY: JK			
CHK. BY: LFS			
DRAWING NO.: L-7033			
SHEET 4 OF 9			

Testing Evaluation Laboratories Inc
 Specimen Complies with Drawing
 Deviations Noted - TEL # 01990817
 Date 10.31.13 Verified by JW

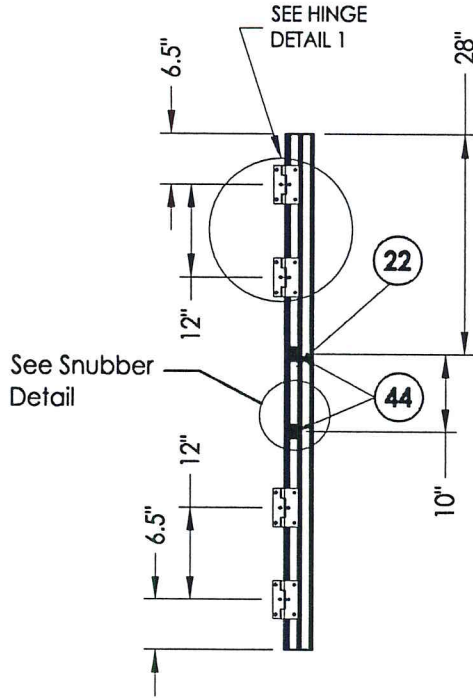

SNUBBER JAMB

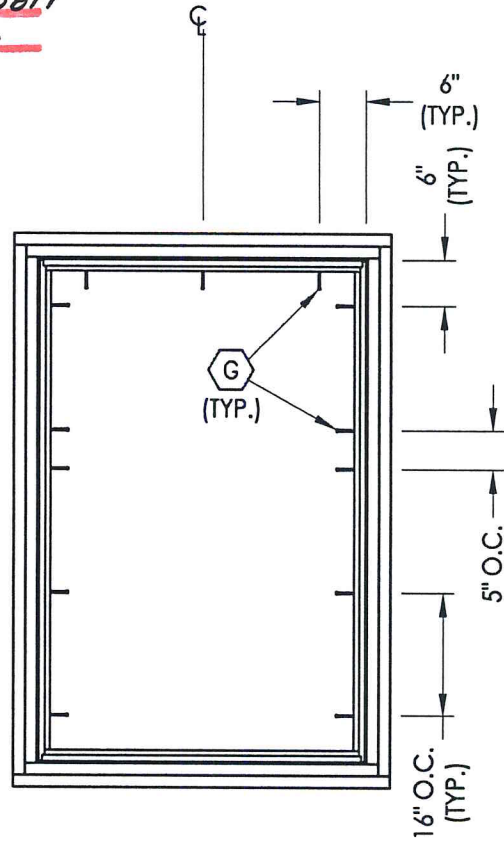

FRAME ANCHORING
2X buck construction

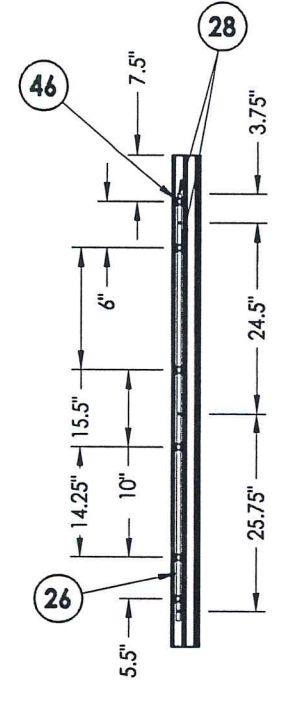

LOCK JAMB
Locking Points (3)

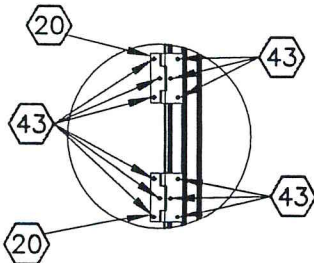

HINGE DETAIL

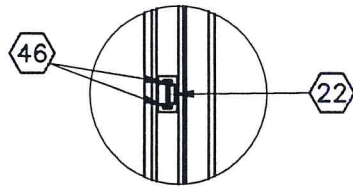

SNUBBER DETAIL

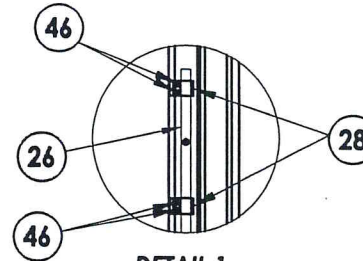

DETAIL 1

PRODUCT:

FLEETWOOD
KONA 3800 CASEMENT WINDOW

PART OR ASSEMBLY:

FRAME ANCHORING

NO.	DATE	BY	REVISIONS

RW BUILDING
CONSULTANTS, INC.
813.659.9197

DATE: 9/25/13

SCALE: N.T.S.

DWG. BY: JK

CHK. BY: LFS

DRAWING NO.:

L-7033

SHEET 5 OF 9

Testing Evaluation Laboratories Inc
 Specimen Complies with Drawing
 Deviations Noted - TEL # 01990817
 SEE HINGE 10-31-13 certified by *Jew*

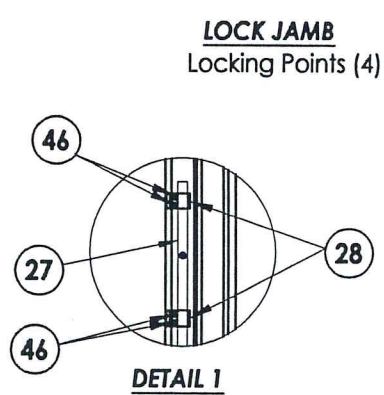
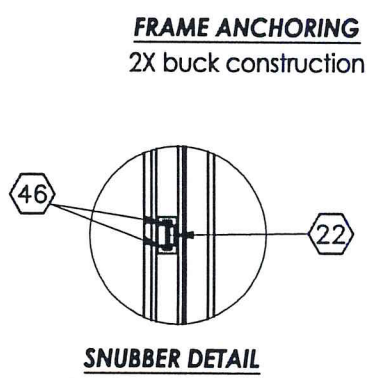
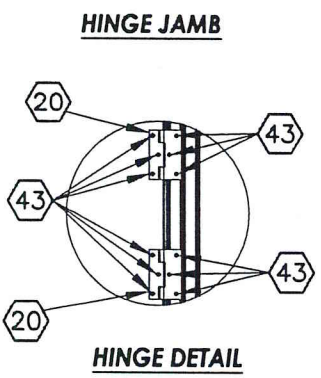
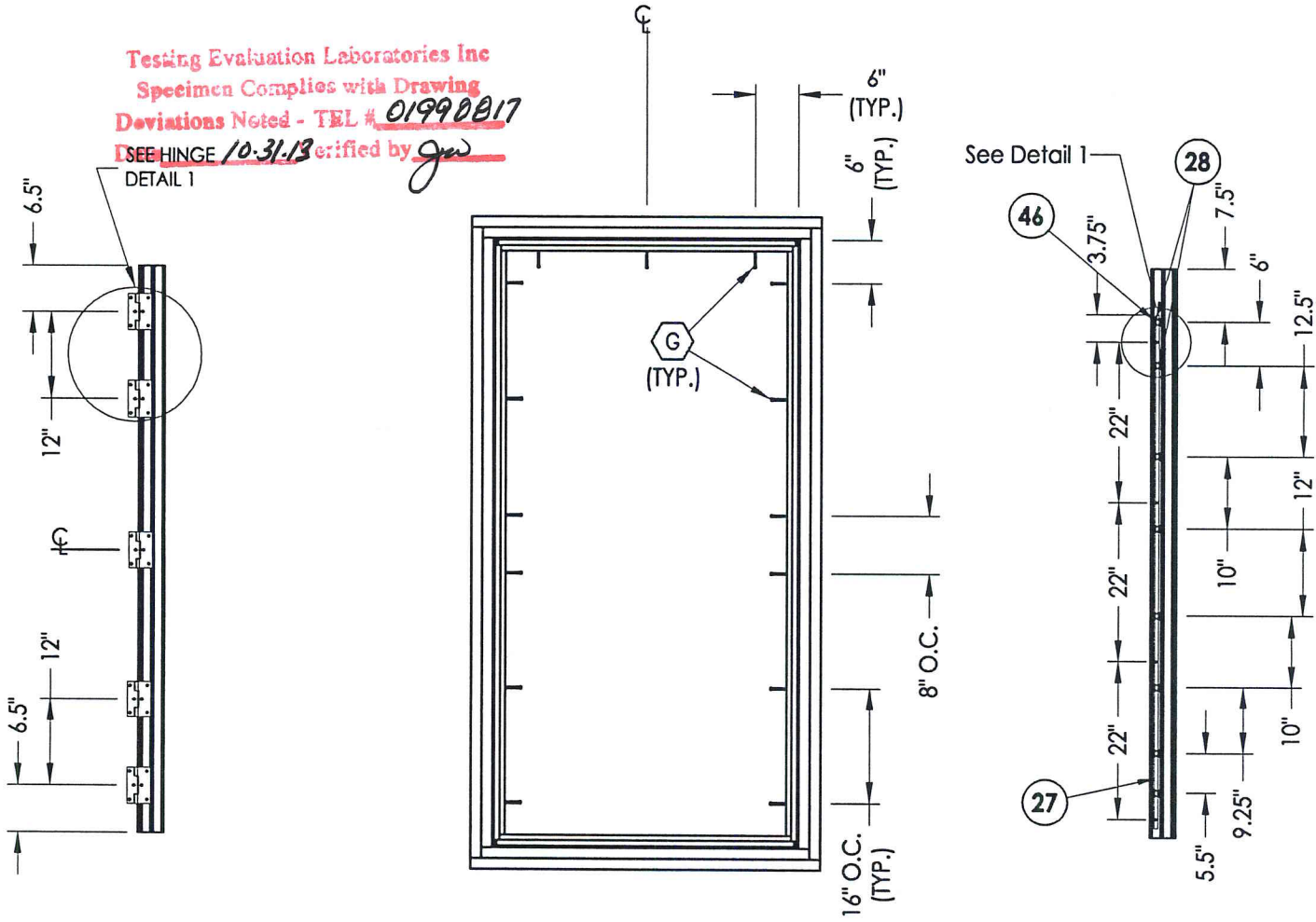

PRODUCT: FLEETWOOD KONA 3800 CASEMENT WINDOW		PART OR ASSEMBLY: FRAME ANCHORING	
NO.	DATE	REVISIONS	BY
 RW BUILDING CONSULTANTS, INC. 813.659.9197			
DATE: 9/25/13			
SCALE: N.T.S.			
DWG. BY: JK			
CHK. BY: LFS			
DRAWING NO.: L-7033			
SHEET 6 OF 9			

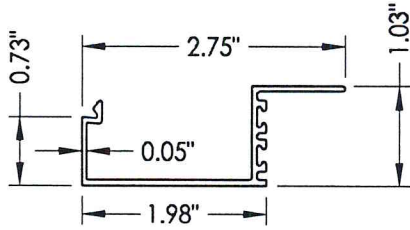

14 INSERT STOP
011448

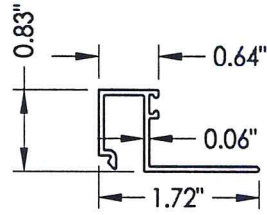

8 GLASS STOP 1-1/4"
901487

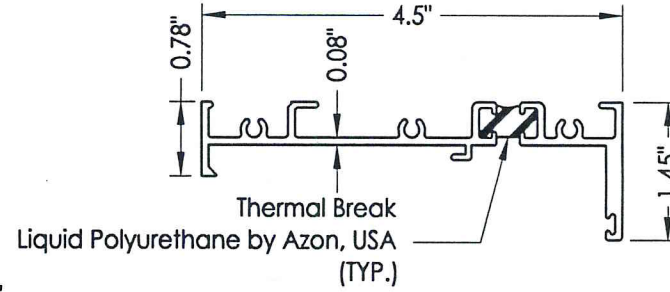

2 KONA BLOCK FRAME
011239

Testing Evaluation Laboratories Inc
 Specimen Complies with Drawing
 Deviations Noted - TEL # 01990817
 Date 10-31-13 Verified by JW

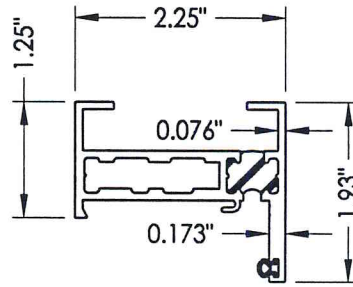

5 BLOCK FRAME
5278C1

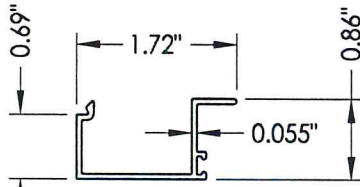

10 GLASS STOP 5/16", 7/16"
007930

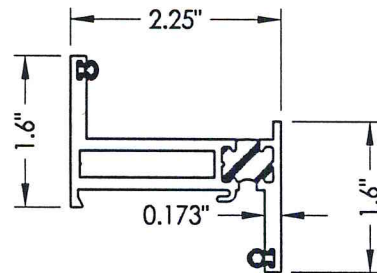

7 ZEE BAR (PANEL)
H006733

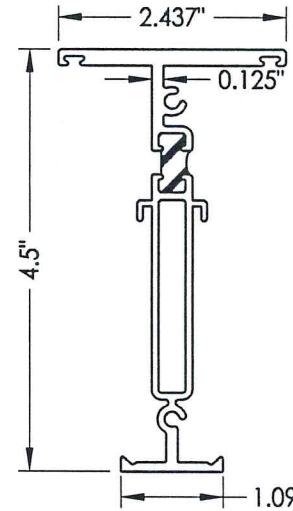

4 MULLION
H011241

PRODUCT:		FLEETWOOD KONA 3800 CASEMENT WINDOW	
PART OR ASSEMBLY:		COMPONENTS	
NO.	DATE	BY	REVISIONS
 RW BUILDING CONSULTANTS, INC. 813.659.9197			
DATE: 9/25/13			
SCALE: N.T.S.			
DWG. BY: JK			
CHK. BY: LFS			
DRAWING NO.: L-7033			
SHEET 7 OF 9			

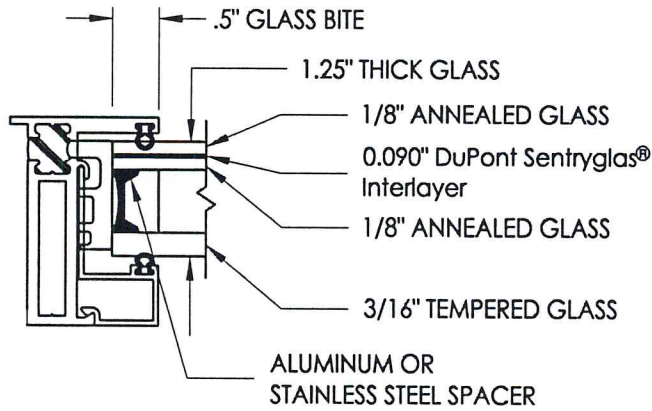

A GLAZING DETAIL

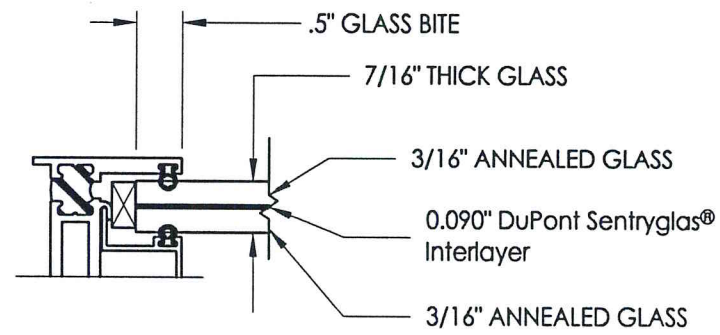

F GLAZING DETAIL

Testing Evaluation Laboratories Inc
 Specimen Complies with Drawing
 Deviations Noted - TEL # 01990817
 Date 10-31-13 Verified by ju

PRODUCT:		FLEETWOOD KONA 3800 CASEMENT WINDOW	
PART OR ASSEMBLY:		COMPONENTS AND GLAZING DETAILS	
NO.	DATE	REVISIONS	BY
DATE: 9/25/13			
SCALE: N.T.S.			
DWG. BY: JK			
CHK. BY: LFS			
DRAWING NO.:			
L-7033			
SHEET <u>8</u> OF <u>9</u>			

FITS WITH PART#

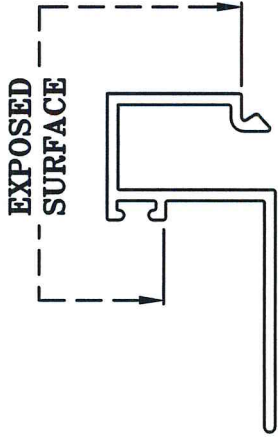

ACTUAL SIZE

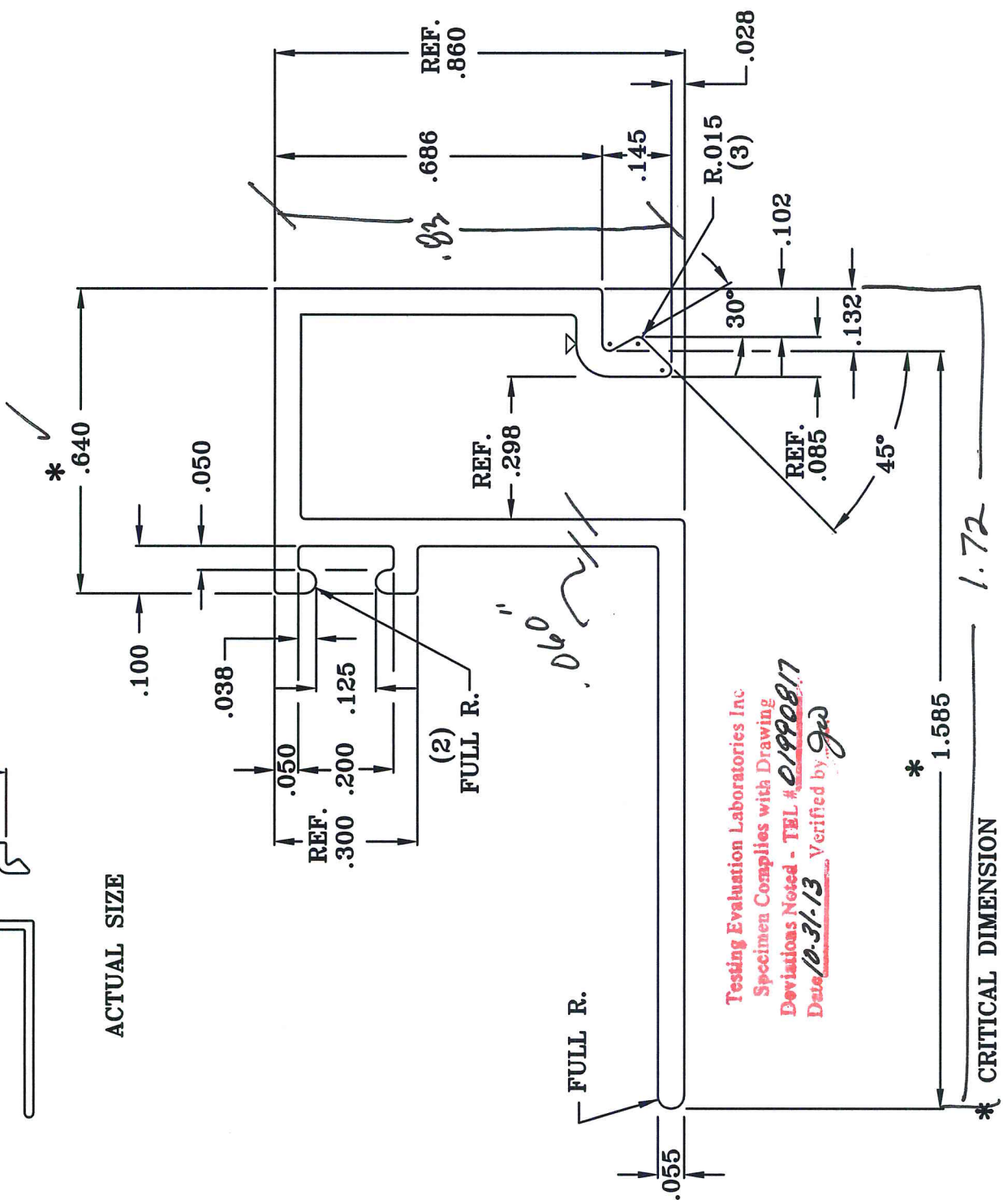

Testing Evaluation Laboratories Inc
 Specimen Complies with Drawing
 Deviations Noted - TEL # 01990817
 Date 10-31-13 Verified by *gjd*

* CRITICAL DIMENSION

NOTE: .055 TYP. WALL EXCEPT AS NOTED UNMARKED CORNERS .010 R.

>.010 R. X .010DEEPI.D. MARK

CONTAINER	7	DIE RING	5	SPACER RING	2
AREA	.202	PORTS	4	BKR	901487
WT/FT	.242	W/P	POCKET	BOLSTER	STD-4
PERL.	7.360	FLE33161		DIE SIZE	9X2
DWN. BY	KEN	DATE	3/12/04	MAT'L	6063-T6
CHKD. BY		DATE		STANDARD TOLERANCES UNLESS OTHERWISE NOTED	
CUSTOMER			FLEETWOOD WINDOWS & DOORS		
SIERRA ALUMINUM COMPANY			PART NO. 05P12		
2345 Fleetwood Drive			SCALE 2:1		
Riverside, California 92509			N/C		
(909)781-7800 FAX (909)781-7864			DIE NO. 901487		

FITS WITH PART#

DIE # _____
DIE # _____

(1.585)
DWG. 05P01, 05P11
05P71,05P81

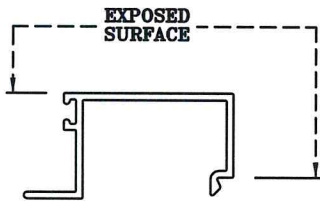
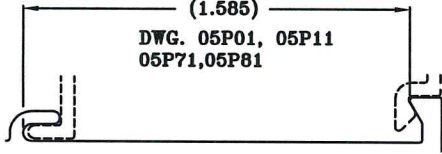

ACTUAL SIZE

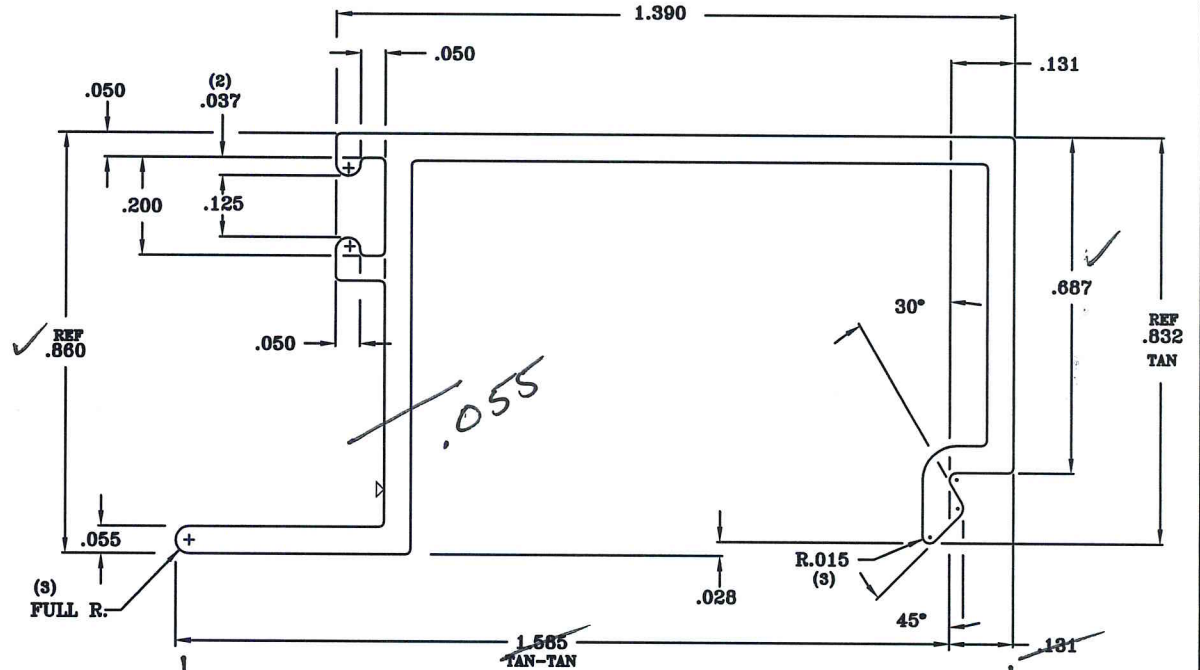

1.72

▷.010 R. X .010HIGH I.D. MARK

NOTE: .055 TYP. WALL EXCEPT AS NOTED
UNMARKED CORNERS .010 R.

CONTAINER	7	DIE RING	4	SPACER RING	3				
AREA	.202	PORTS	4	HEX	2372				
WT/PT	.242	W/P	-	BOLSTER	4-9				
PKEL	7.337	FLE9686		DIE SIZE	9x1				
DWN. BY	HILDA	DATE	6/03/94	MAT'L	6063-T6				
CHEK. BY		DATE		STANDARD TOLERANCES UNLESS OTHERWISE NOTED		LET.		REVISION	BY DATE
SIERRA ALUMINUM COMPANY		CUSTOMER		SCALE	PART NO.				
2345 Fleetwood Drive		FLEETWOOD ALUMINUM PRODUCTS		4:1	05P08				
Riverside, California 92509		PART NAME		-	DIE NO.				
(909)781-7800 FAX (909)781-7864		GLASS STOP 1/2" ...5000			007930				

Testing Evaluation Laboratories Inc
Specimen Complies with Drawing
Deviations Noted - TEL # 01990817
Date 10-31-13 Verified by gaw

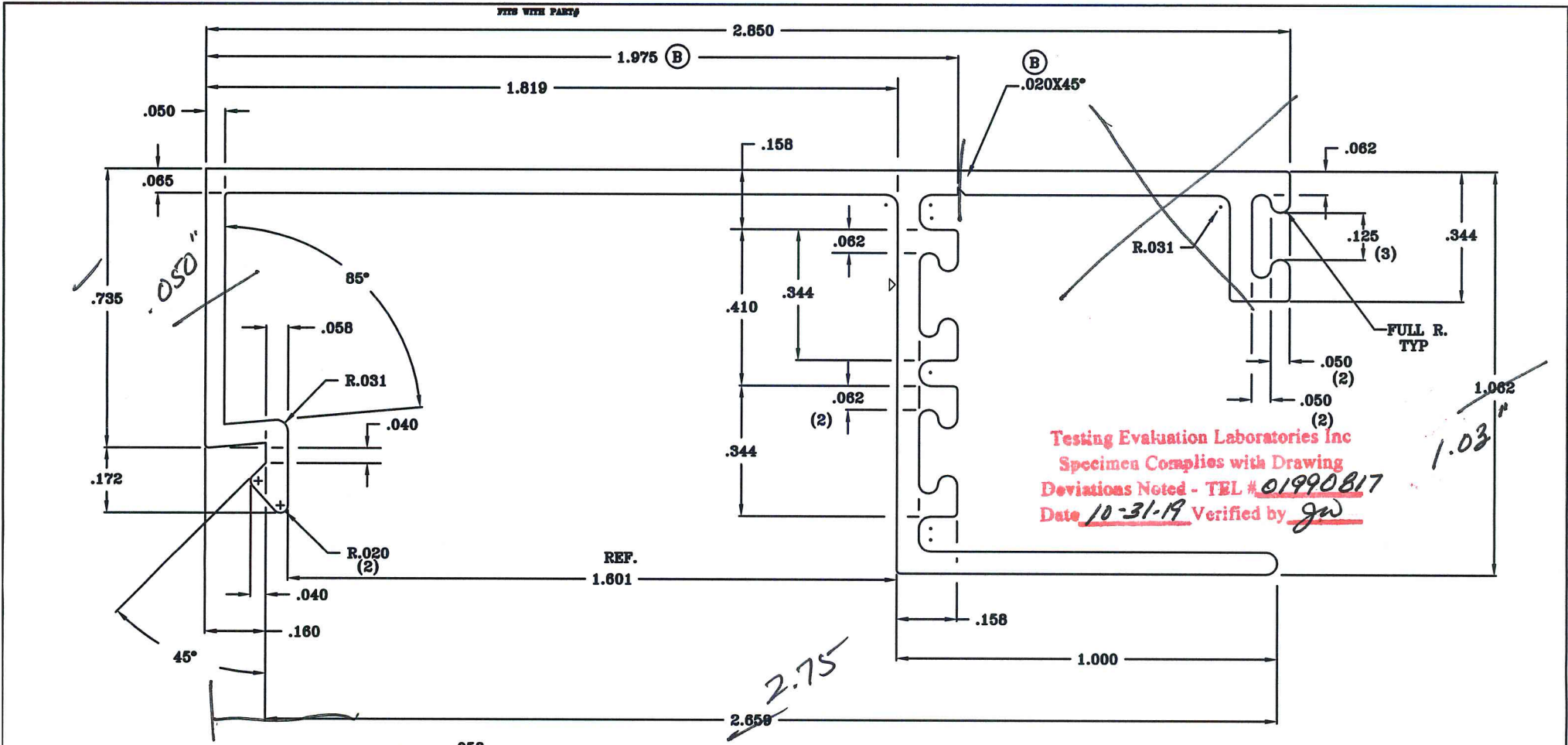

Testing Evaluation Laboratories Inc
 Specimen Complies with Drawing
 Deviations Noted - TEL # 01990817
 Date 10-31-19 Verified by gw

∅.010 R. X .010DEEPI.D. MARK NOTE: .058 TYP. WALL THICKNESS AS NOTED UNMARKED CORNERS .010 R.

CONTAINER	8	DIE RING	5	SPACER RING	2				
AREA	.415	PORTS	3	DER	011448				
WT/PT	.498	V/P	POCKET	BOLSTER	3-6				
PHIL	13.469	FLE	28807	DIE SIZE	9X2				
DWN. BY	KEN	DATE	4/24/02	MAT'L.	6063-T6	D	RELOCATE .000245"	ID	9/29/08
CHGD. BY		DATE		STANDARD TOLERANCES UNLESS OTHERWISE NOTED		LET.	REVISION	BY	DATE
CUSTOMER				FLEETWOOD ALUMINUM		SCALE	4:1	PART NO.	3811
PART NAME				GLASS STOP			N/C	DIE NO.	011448
SIERRA ALUMINUM COMPANY 2345 Fleetwood Drive Riverside, California 92509 (909)781-7800 FAX (909)781-7864									

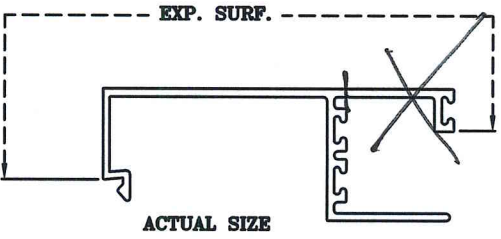

Testing Evaluation Laboratories Inc
 Specimen Complies with Drawing
 Deviations Noted - TEL # 01990817
 Date 10-31-19 Verified by gw

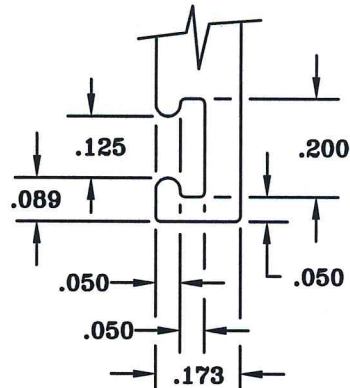
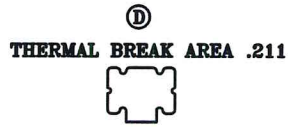

DETAIL "B"
 (2 PLCS.)

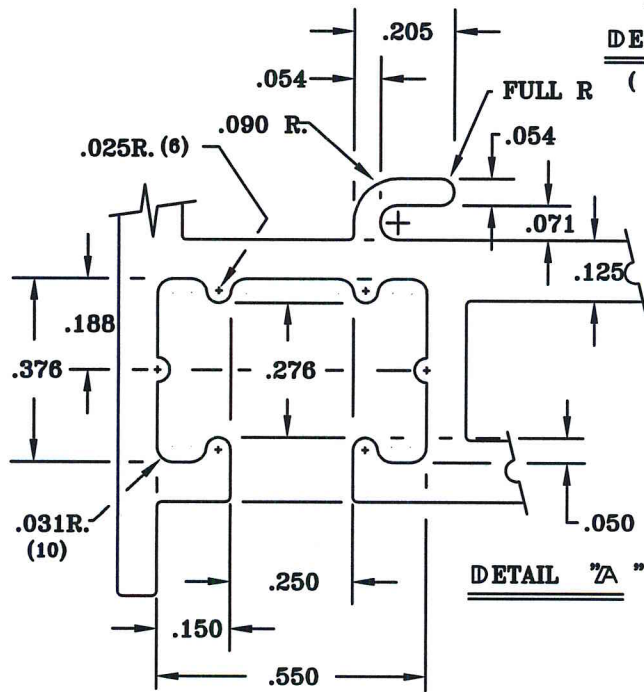

DETAIL "A"

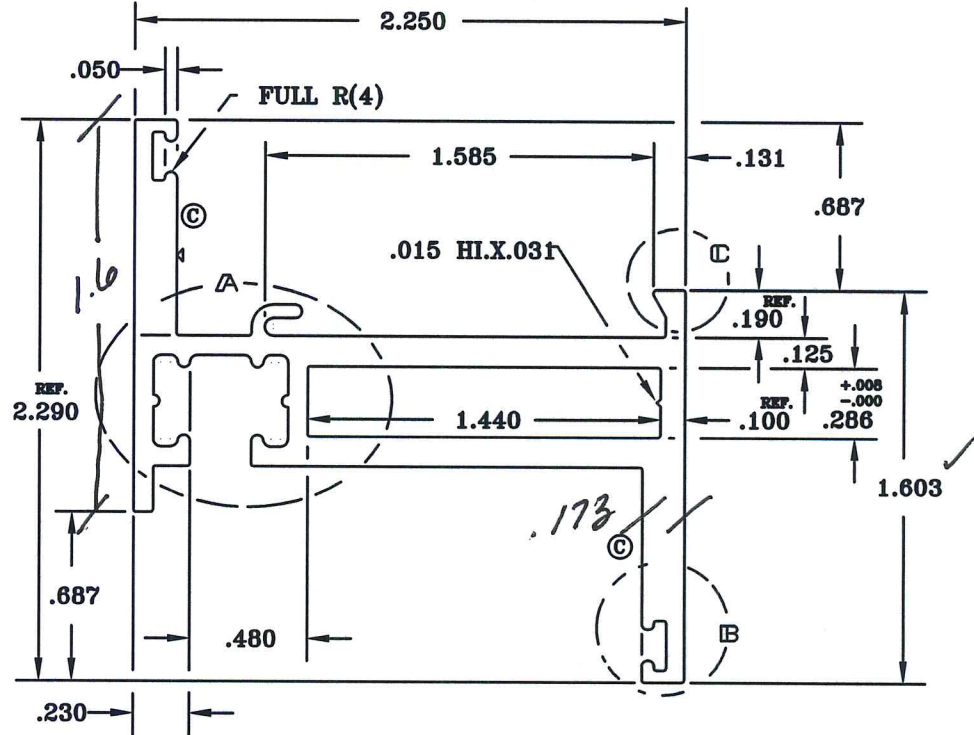

▷.010 R. X .010DEEPI.D. MARK

NOTE: .080 TYP. WALL THICKNESS AS NOTED
 UNMARKED CORNERS .010 R.

CONTAINER	DEE RING	SPACER RING					
AREA .897	PORTS 1	DEE -					
WT/FT 1.076	W/P -	BOLSTER 1-2	D	ADD THERMAL BREAK AREA	TAS	2/21/06	
PERL. 16.078	FLEE6042	DEE SIZE 9X5	C	REMOVED UNDERCUTS WT/FT. WAS .978,F16.433	EO	3/14/03	
DWN. BY <i>Hido</i>	DATE 3/14/03	MAT'L 6063-T6	B	REMOVED .186 STEP WT/FT. WAS 1.006,F16.416	EO	7/19/03	
CHD. BY	DATE	STANDARD TOLERANCES UNLESS OTHERWISE NOTED	LIST.	REVISION	BY	DATE	
		CUSTOMER		SCALE	PART NO.		
SIERRA ALUMINUM COMPANY		FLEETWOOD ALUMINUM PRODUCTS, INC.		3:1	05P11		
2345 Fleetwood Drive Riverside, California 92509 (909)781-7800 FAX (909)781-7864		PART NAME			DEE NO.		
		ZEE BAR			H-006733		

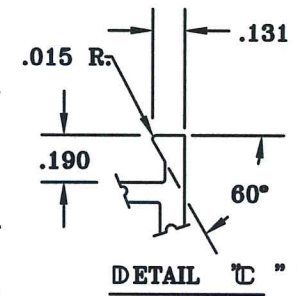
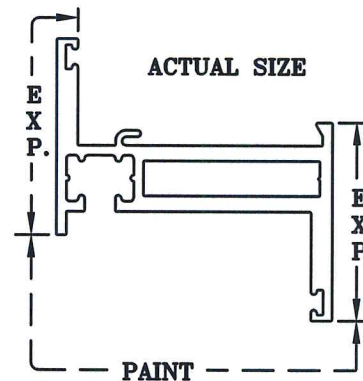

FITS WITH PART# FILE 27177, FILE 27179, & FILE 27180

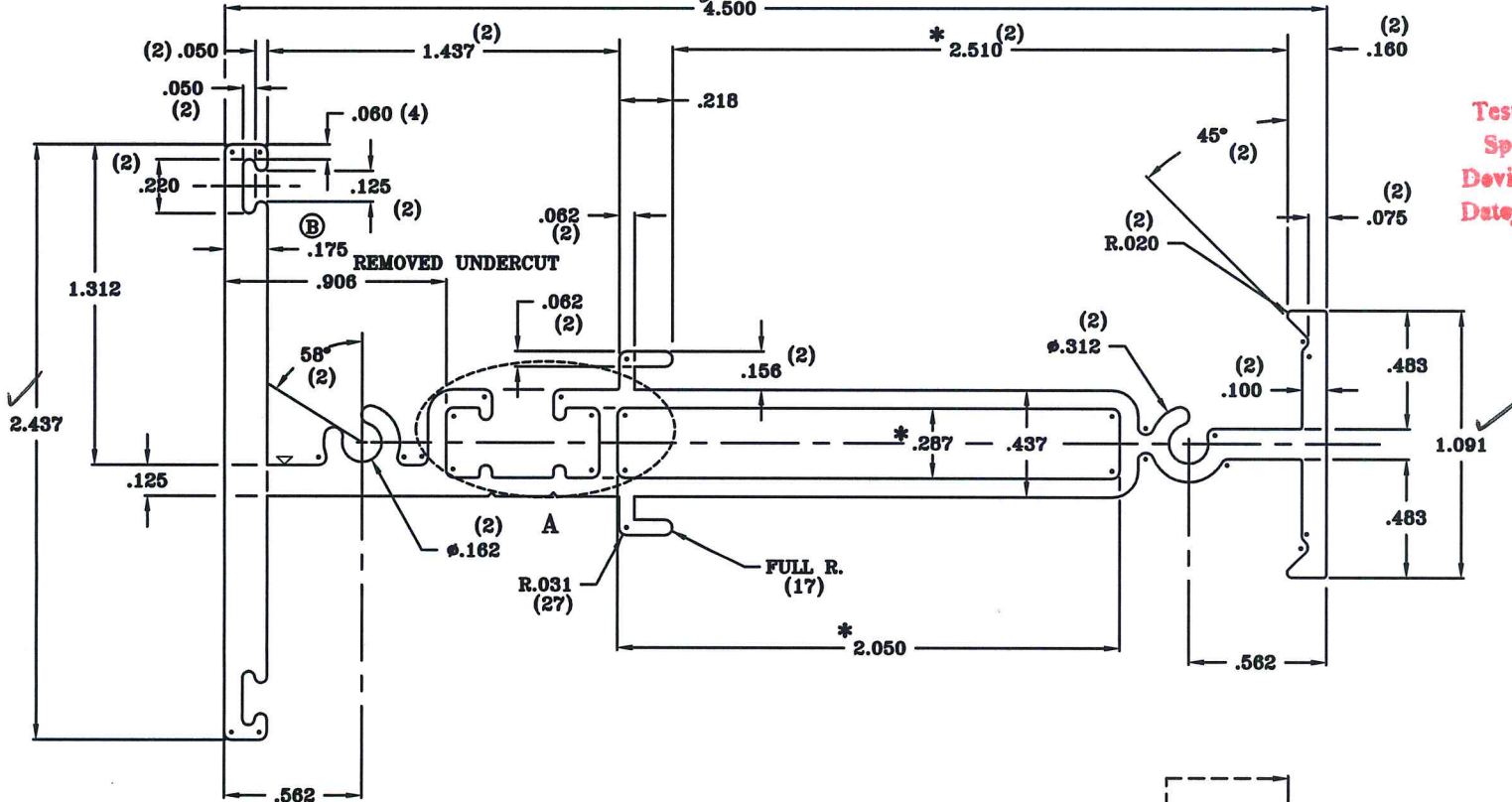

Testing Evaluation Laboratories Inc
 Specimen Complies with Drawing
 Deviations Noted - TEL # 01990817
 Date 10-31-13 Verified by *ju*

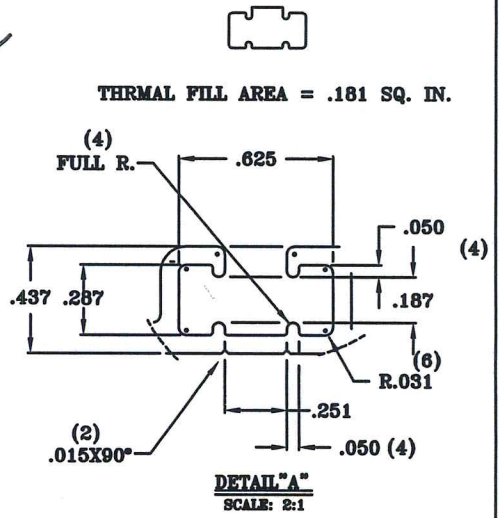

* CRITICAL DIMENSION

∅.010 R. X .010DEEPL.D. MARK NOTE: .075 TYP. WALL HEIGHT AS NOTED UNMARKED CORNERS .010 R.

CONTAINER	8	DIE RING	5	SPACER RING	2				
AREA	1.232	POINTS	1	DIE	-				
WT/FT	1.478	W/P	-	BOLSTER	11238				
PNL	25.766	FLE 27178		DIE SIZE	9X5	B	ARMED EXPOSED SURFACE	ED	11/18/08
DWN. BY	KEN	DATE	11/12/03	MAT'L.	6063-T6	B	REMOVED UNDERCUT	ED	11/12/08
CRD. BY		DATE		STANDARD TOLERANCES UNLESS OTHERWISE NOTED		LET.	REVISION	BY	DATE
SIERRA ALUMINUM COMPANY				CUSTOMER	FLEETWOOD ALUMINUM	SCALE	PART NO.	3806	
2345 Fleetwood Drive Riverside, California 92509 (909)781-7800 FAX (909)781-7864				PART NAME	MULLION	1900 N/C	DIE NO.	H-011241	

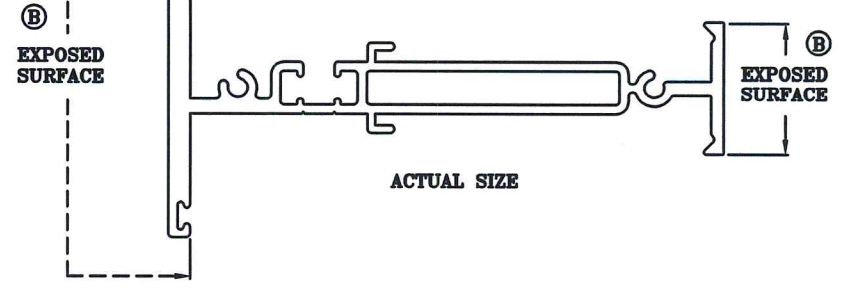

FILE 27177, FILE 27179, & FILE 27180

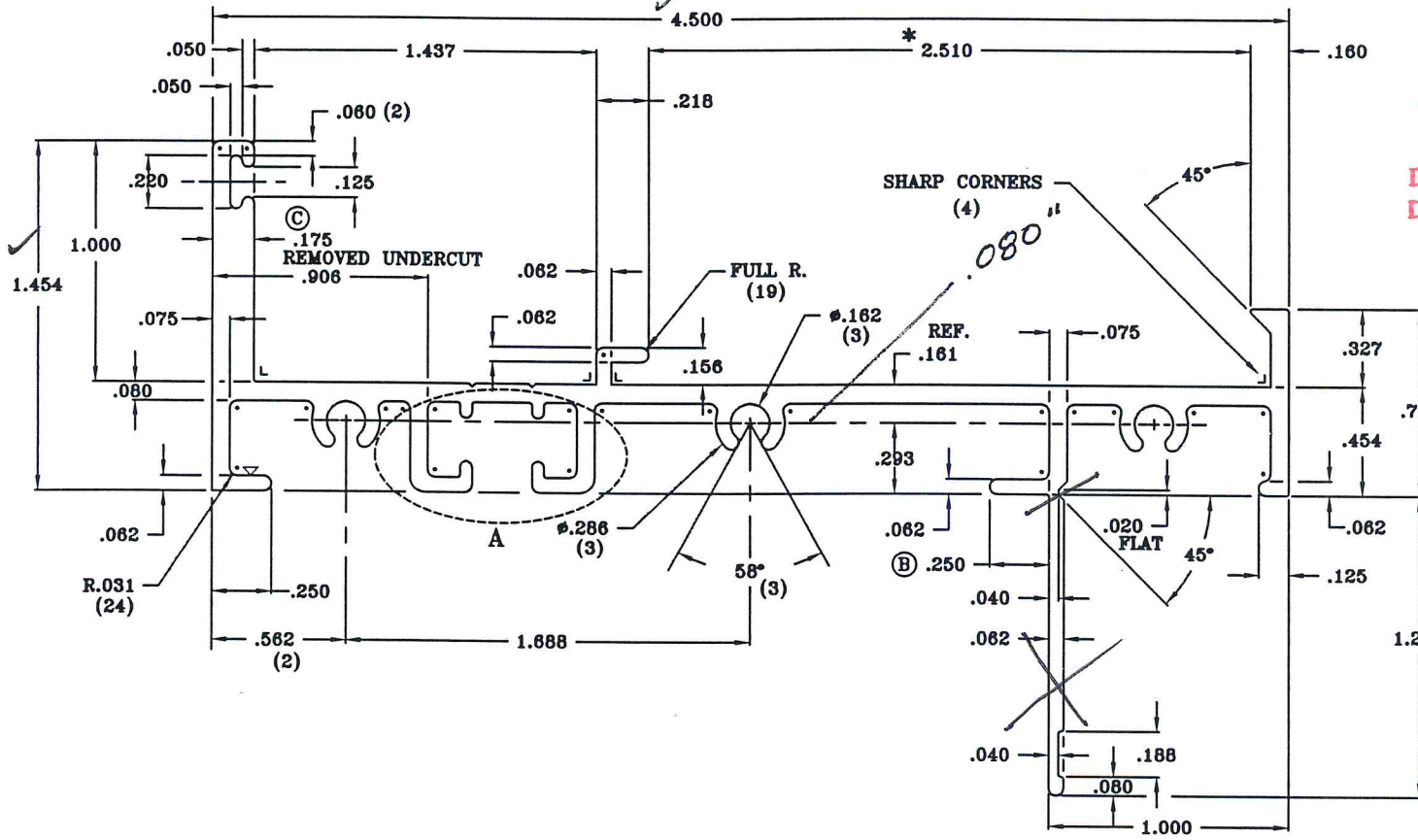

Testing Evaluation Laboratories Inc
 Specimen Complies with Drawing
 Deviations Noted - TEL # 01990817
 Date 10-31-13 Verified by *gwl*

Thermal Fill Area = .193 SQ. IN.

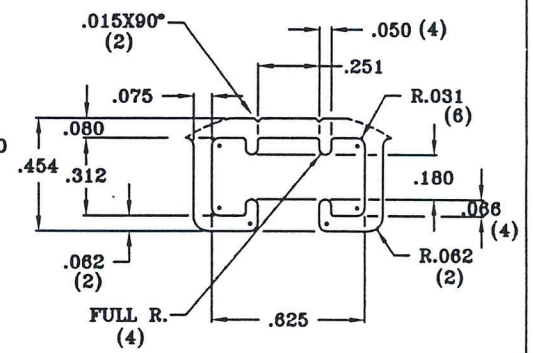

DETAIL "A"
 SCALE: 4:1

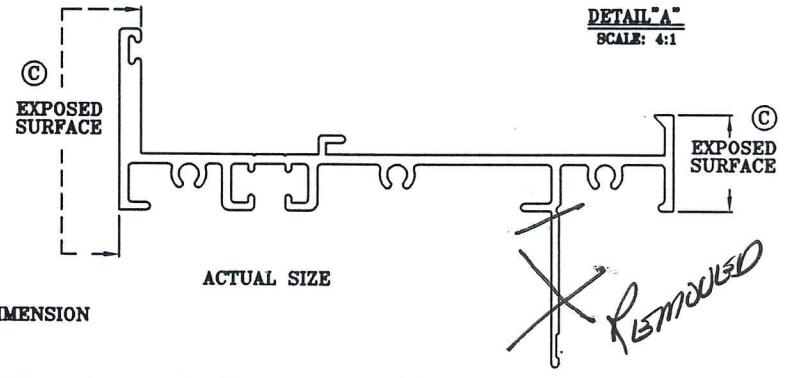

∅.010 R. X .010DEEPI.D. MARK NOTE: .075 TYP. WALL EXCEPT AS NOTED UNMARKED CORNERS .010 R.

CONTAINER	7/8	DIE KING	5	SPACER KING	2				
AREA	.921	POSTS	1	REL	11238				
WT/PT	1.105	W/P	POCKET	BOLSTER	11238	C	ADDED EXPOSED SURFACE ADDED BLOCK TO PART MARK	ED	11/18/08
PHBL	22.854	FLE	27176	DIE SIZE	9X2	C	REMOVED UNDERCUT WT/PT. WAS 1.087 P; 23.097	ED	11/18/08
DRN. BY	KEN	DATE	11/12/03	MAT'L	6063-T6	B	ADDED MISSING DIM.	ED	7/28/01
CHEK. BY		DATE		STANDARD TOLERANCES UNLESS OTHERWISE NOTED		LET.	REVISION	BY	DATE
SIERRA ALUMINUM COMPANY 2345 Fleetwood Drive Riverside, California 92509 (909)781-7800 FAX (909)781-7884				CUSTOMER FLEETWOOD ALUMINUM		SCALE 2:1	PART NO. 3805		
				PART NAME 4.500 FRAME BLOCK		930 N/C	DIE NO. 011239		

* CRITICAL DIMENSION