



# Testing Evaluation Laboratories, Inc.

2002 Wood Court Suite 1 – Plant City, FL 33563

Phone: 813-754-9887

AAMA/WDMA/CSA 101/I.S.2/A440-08

Canadian Supplement A440S1-09

## TEST REPORT SUMMARY

Test Report Issued To:

**FLEETWOOD WINDOWS AND DOORS**

1 Fleetwood Way

Corona, CA 92879

### KONA 3800 Impact Resistant Aluminum Fixed Windows

Title	Summary of Results		
	Specimen 1	Specimen 2	Specimen 3
Primary Product Designator	Class LC- PG60 1524 x 3048 (60 x 120) Type FW	Class LC- PG65 1270 x 3658 (50 x 144) Type FW	Class LC- PG60 1524 x 3048 (60 x 120) Type FW
Design Pressure	+2873/-2873 Pa (+60.0/- 60.0 psf)	+3112/-3112 Pa (+65.0/- 65.0 psf)	+2873/-2873 Pa (+60.0/- 60.0 psf)
Air Infiltration	0.00 L/s/m <sup>2</sup> (0.00 scfm/ft <sup>2</sup> )	0.00 L/s/m <sup>2</sup> (0.00 scfm/ft <sup>2</sup> )	0.00 L/s/m <sup>2</sup> (0.00 scfm/ft <sup>2</sup> )
Air Infiltration/Exfiltration (A440S1-09)	Level Fixed: < 0.20 L/s•m <sup>2</sup>	Level Fixed: < 0.20 L/s•m <sup>2</sup>	Level Fixed: < 0.20 L/s•m <sup>2</sup>
Water Resistance	718 Pa (15.0 psf)	718 Pa (15.0 psf)	718 Pa (15.0 psf)
Structural Test Pressure	+4309/-4309 Pa (+90.0/- 90.0 psf)	+4668/-4668 Pa (+97.5/- 97.5 psf)	+4309/-4309 Pa (+90.0/- 90.0 psf)
Forced Entry	No Entry	No Entry	No Entry

Title	Summary of Results	
	Specimen 4	Specimen 5
Primary Product Designator	Class LC- PG65 2438 x 3048 (96 x 120) Type FW	Class LC- PG65 3048 x 2438 (120 x 96) Type FW
Design Pressure	+3112/-3112 Pa (+65.0/- 65.0 psf)	+3112/-3591 Pa (+65.0/- 75.0 psf)
Air Infiltration	See Specimen 5 for Results	0.00 L/s/m <sup>2</sup> (0.00 scfm/ft <sup>2</sup> )
Air Infiltration/Exfiltration (A440S1-09)	See Specimen 5 for Results	Level Fixed: < 0.20 L/s•m <sup>2</sup>
Water Resistance	See Specimen 5 for Results	718 Pa (15.0 psf)
Structural Test Pressure	+4668/-4668 Pa (+97.5/- 97.5 psf)	+4668/-5387 Pa (+97.5/- 112.5 psf)
Forced Entry	No Entry	No Entry

Reference should be made to Report No. TEL 01991007 for complete test specimen description and data. For corresponding data regarding ASTM E1886 and ASTM E1996 reference should be made to Report No. TEL 01991008.

For Testing Evaluation Laboratories, Inc.

Vivian K. Wright,  
President



# Testing Evaluation Laboratories, Inc.

2002 Wood Court Suite 1 – Plant City, FL 33563

Phone: 813-754-9887

**AAMA/WDMA/CSA 101/I.S.2/A440-08  
Canadian Supplement A440S1-09**

**Issued to:**

**FLEETWOOD WINDOWS AND DOORS  
1 Fleetwood Way  
Corona, CA 92879**

**IAS Lab Certification Number: TL-299**

**Report No: TEL 01991007**

**Test Dates: January 13-20, 2014**

**Report Date: March 21, 2014**

**Revision Date: June 10, 2014**

**Project Summary:** Testing Evaluation Laboratories, Inc. (TEL) was contracted by Fleetwood Windows and Doors to perform tests on the Kona 3800 Fixed Windows at TEL's Plant City, FL test facility. Please see each individual specimen results for information on which *Performance Grade* was *successfully achieved by each specimen*.

**Test Specifications:** The test specimens were evaluated in accordance with the following:

***AAMA/WDMA/CSA 101/I.S.2/A440-08 and Canadian Supplement A440S1-09  
Standard Specification for Windows, Doors and Unit Skylights***

**Test Specimen Description:**

<b>Series / Model:</b>	<b>Kona 3800 Fixed Windows</b>
<b>Type:</b>	<b>Aluminum Fixed Windows</b>
<b>Overall Size:</b>	<b>60.00" x 120.00 – Specimen 1 – (O) – Direct Mount 50.00" x 144.00" – Specimen 2 – (O) – Fin Mount 60.00" x 120.00" – Specimen 3 – (O) – Fin Mount 96.00" x 120.00" – Specimen 4 – (O/O/O) – Direct Mount 120.00" x 96.00" – Specimen 5 – (OOO) – Fin Mount</b>
<b>Daylight Opening:</b>	<b>57.10" x 117.10" – Specimen 1 – (O) 47.10" x 141.10" – Specimen 2 – (O) 57.10" x 117.10" – Specimen 3 – (O) 93.06" x 37.375" – Specimen 4 – (O/O/O) - Top/Bottom Panels 93.06" x 37.50" – Specimen 4 – (O/O/O) – Center Panel 37.375" x 93.06" – Specimen 5 – (OOO) - End panels 37.50" x 93.06" – Specimen 5 – (OOO) - Center panel</b>

**Test Specimen Description: Continued**

**Glazing Detail:** See attached drawing numbers L-7030, L-7108 and L-7109 for glazing details.

**Frame Material:** Aluminum

**Finish:** Mill Finish

**For Tested Elevation, Vertical Cross Sections, Horizontal Cross Sections, Components, Frame Anchoring, Glazing Detail and Bill of Materials See Attached Drawing #'s L-7030, L-7108 and L- 7109.**

**Test Results: Specimen 1: 1524 mm (60.00") x 3048 mm (120.00") KONA 3800 Series Aluminum Fixed Window  
Class LC- PG60 1524 x 3048 (60 x 120) Type FW**

The test results are tabulated as follows:

<u>Paragraph</u>	<u>Title of Test – Test Method</u>	<u>Results</u>	<u>Allowed</u>
5.3.2.1	Air Leakage Resistance per ASTM E283 @ 75 Pa (1.57 psf)	0.000 L/s/m <sup>2</sup> 0.000 scfm/ft <sup>2</sup>	1.50 L/s/m <sup>2</sup> (0.30 SCFM/FT <sup>2</sup> )
	Air Infiltration per ASTM E283 @ 299 Pa (6.24 psf)	0.000 L/s/m <sup>2</sup> (0.000 SCFM/FT <sup>2</sup> )	1.50 L/s/m <sup>2</sup> (0.30 SCFM/FT <sup>2</sup> )
	Air Exfiltration per ASTM E283 @ 75 Pa (1.57 psf)	0.000 L/s/m <sup>2</sup> (0.000 SCFM/FT <sup>2</sup> )	1.50 L/s/m <sup>2</sup> (0.30 SCFM/FT <sup>2</sup> )
	Air Exfiltration per ASTM E283 @ 299 Pa (6.24 psf)	0.000 L/s/m <sup>2</sup> (0.000 SCFM/FT <sup>2</sup> )	1.50 L/s/m <sup>2</sup> (0.30 SCFM/FT <sup>2</sup> )
Note #1:	<i>The tested specimen meets (or exceeds) the performance levels specified in AAMA/WDMA/CSA 101/I.S.2/A440-08 (A440 S1-09) for air infiltration/exfiltration.</i>		
5.3.3.2	Water Penetration Resistance per ASTM E547		See Note #2
5.3.4.2	Uniform Load Deflection Test @ Design per ASTM E330		See Note #2
5.3.4.3	Uniform Load Structural Test @ 150% of Design Pressure per ASTM E330		See Note #2
Note #2:	<i>The client opted to start at a pressure higher than the minimum required. Those results are listed under "Optional Performance".</i>		
5.3.5	Forced-entry Resistance Test per ASTM F588		
	Type: D                      Grade: 10		
	Disassembly Test	No Entry	No Entry
<b>Optional Performance</b>			
4.3.2.1	Water Penetration Resistance per ASTM E547 @ 718 Pa (15.0 psf)	No Leakage	No Leakage



Test Results: (Continued Spec 1)

The test results are tabulated as follows:

4.3.2.1 Uniform Load Deflection per ASTM E330

Range Allowable	Time (seconds)	Load Pa (psf)	Location mm (in.)	Deflection mm (in.)	
Half Test Positive	10	1436 (30.00)			
Test Positive	10	2873 (60.00)	1	0.000 (0.000)	See Note #3
Half Test Negative	10	1436 (30.00)			
Test Negative	10	2873 (60.00)	1	0.000 (0.000)	See Note #3

**Note #3:** *The deflections reported are not limited by AAMA/WDMA/CSA101/1.S.2/A440-08 (A440 S1-09) for this product designation. The deflection data is recorded in this report for special code compliance and information only*

Range	Time (Seconds)	Load Pa (psf)	Location	Deflection mm(in.)	Set mm(in.)	Allowable mm(in.)
Half Proof Positive	10	2155 (45.00)				
Proof Positive	10	4309 (90.00)	1	0.889 (0.035)	0.000 (0.000)	1.219 (0.048)
Half Proof Negative	10	2155 (45.00)				
Proof Negative	10	4309 (90.00)	1	1.295 (0.051)	0.152 (0.006)	1.219 (0.048)

**Note #4:** *Deflection/Set measurements taken between anchors*

**Test Results: Specimen 2: 1270 mm (50.00") x 3658 mm (144.00") KONA 3800 Series Aluminum Fixed Window Class LC- PG65 1270 x 3658 (50 x 144) Type FW**

The test results are tabulated as follows:

<u>Paragraph</u>	<u>Title of Test – Test Method</u>	<u>Results</u>	<u>Allowed</u>
5.3.2.1	Air Leakage Resistance per ASTM E283 @ 75 Pa (1.57 psf)	0.000 L/s/m <sup>2</sup> 0.000 scfm/ft <sup>2</sup>	1.50 L/s/m <sup>2</sup> (0.30 SCFM/FT <sup>2</sup> )
	Air Infiltration per ASTM E283 @ 299 Pa (6.24 psf)	0.000 L/s/m <sup>2</sup> (0.000 SCFM/FT <sup>2</sup> )	1.50 L/s/m <sup>2</sup> (0.30 SCFM/FT <sup>2</sup> )
	Air Exfiltration per ASTM E283 @ 75 Pa (1.57 psf)	0.000 L/s/m <sup>2</sup> (0.000 SCFM/FT <sup>2</sup> )	1.50 L/s/m <sup>2</sup> (0.30 SCFM/FT <sup>2</sup> )
	Air Exfiltration per ASTM E283 @ 299 Pa (6.24 psf)	0.000 L/s/m <sup>2</sup> (0.000 SCFM/FT <sup>2</sup> )	1.50 L/s/m <sup>2</sup> (0.30 SCFM/FT <sup>2</sup> )
Note #1:	<i>The tested specimen meets (or exceeds) the performance levels specified in AAMA/WDMA/CSA 101/I.S.2/A440-08 (A440 S1-09) for air infiltration/exfiltration.</i>		
5.3.3.2	Water Penetration Resistance per ASTM E547		See Note #2
5.3.4.2	Uniform Load Deflection Test @ Design per ASTM E330		See Note #2
5.3.4.3	Uniform Load Structural Test @ 150% of Design Pressure per ASTM E330		See Note #2
Note #2:	<i>The client opted to start at a pressure higher than the minimum required. Those results are listed under "Optional Performance".</i>		
5.3.5	Forced-entry Resistance Test per ASTM F588		
	Type: D                      Grade: 10		
	Disassembly Test	No Entry	No Entry
Optional Performance			
4.3.2.1	Water Penetration Resistance per ASTM E547 @ 718 Pa (15.0 psf)	No Leakage	No Leakage

**Test Results: (Continued Spec 2)**

The test results are tabulated as follows:

**4.3.2.1 Uniform Load Deflection per ASTM E330**

Range Allowable	Time (seconds)	Load Pa (psf)	Location mm (in.)	Deflection mm (in.)	
Half Test Positive	10	1556 (32.50)			
Test Positive	10	3112 (65.00)	1	0.000 (0.000)	See Note #3
Half Test Negative	10	1556 (32.50)			
Test Negative	10	3112 (65.00)	1	0.127 (0.005)	See Note #3

**Note #3:** *The deflections reported are not limited by AAMA/WDMA/CSA101/I.S.2/A440-08 (A440 S1-09) for this product designation. The deflection data is recorded in this report for special code compliance and information only*

Range	Time (Seconds)	Load Pa (psf)	Location	Deflection mm(in.)	Set mm(in.)	Allowable mm(in.)
Half Proof Positive	10	2334 (48.75)				
Proof Positive	10	4668 (97.50)	1	0.127 (0.005)	0.025 (0.001)	1.219 (0.048)
Half Proof Negative	10	2334 (48.75)				
Proof Negative	10	4668 (97.50)	1	0.380 (0.013)	0.178 (0.007)	1.219 (0.048)

**Note #4:** *Deflection/Set measurements taken between anchors*

**Test Results: Specimen 3: 1524 mm (60.00") x 3048 mm (120.00") KONA 3800 Series Aluminum Fixed Window Class LC- PG60 1524 x 3048 (60 x 120) Type FW**

The test results are tabulated as follows:

<u>Paragraph</u>	<u>Title of Test – Test Method</u>	<u>Results</u>	<u>Allowed</u>
5.3.2.1	Air Leakage Resistance per ASTM E283 @ 75 Pa (1.57 psf)	0.000 L/s/m <sup>2</sup> 0.000 scfm/ft <sup>2</sup>	1.50 L/s/m <sup>2</sup> (0.30 SCFM/FT <sup>2</sup> )
	Air Infiltration per ASTM E283 @ 299 Pa (6.24 psf)	0.000 L/s/m <sup>2</sup> (0.000 SCFM/FT <sup>2</sup> )	1.50 L/s/m <sup>2</sup> (0.30 SCFM/FT <sup>2</sup> )
	Air Exfiltration per ASTM E283 @ 75 Pa (1.57 psf)	0.000 L/s/m <sup>2</sup> (0.000 SCFM/FT <sup>2</sup> )	1.50 L/s/m <sup>2</sup> (0.30 SCFM/FT <sup>2</sup> )
	Air Exfiltration per ASTM E283 @ 299 Pa (6.24 psf)	0.000 L/s/m <sup>2</sup> (0.000 SCFM/FT <sup>2</sup> )	1.50 L/s/m <sup>2</sup> (0.30 SCFM/FT <sup>2</sup> )
Note #1:	<i>The tested specimen meets (or exceeds) the performance levels specified in AAMA/WDMA/CSA 101/I.S.2/A440-08 (A440 S1-09) for air infiltration/exfiltration.</i>		
5.3.3.2	Water Penetration Resistance per ASTM E547		See Note #2
5.3.4.2	Uniform Load Deflection Test @ Design per ASTM E330		See Note #2
5.3.4.3	Uniform Load Structural Test @ 150% of Design Pressure per ASTM E330		See Note #2
Note #2:	<i>The client opted to start at a pressure higher than the minimum required. Those results are listed under "Optional Performance".</i>		
5.3.5	Forced-entry Resistance Test per ASTM F588		
	Type: D                      Grade: 10		
	Disassembly Test	No Entry	No Entry
<b>Optional Performance</b>			
4.3.2.1	Water Penetration Resistance per ASTM E547 @ 718 Pa (15.0 psf)	No Leakage	No Leakage

**Test Results: (Continued Spec 3)**

The test results are tabulated as follows:

**4.3.2.1 Uniform Load Deflection per ASTM E330**

Range Allowable	Time (seconds)	Load Pa (psf)	Location mm (in.)	Deflection mm (in.)	
Half Test Positive	10	1436 (30.00)			
Test Positive	10	2873 (60.00)	1	0.000 (0.000)	See Note #3
Half Test Negative	10	1436 (30.00)			
Test Negative	10	2873 (60.00)	1	0.483 (0.019)	See Note #3

**Note #3:** *The deflections reported are not limited by AAMA/WDMA/CSA101/I.S.2/A440-08 (A440 S1-09) for this product designation. The deflection data is recorded in this report for special code compliance and information only*

Range	Time (Seconds)	Load Pa (psf)	Location	Deflection mm(in.)	Set mm(in.)	Allowable mm(in.)
Half Proof Positive	10	2155 (45.00)				
Proof Positive	10	4309 (90.00)	1	0.152 (0.006)	0.051 (0.002)	1.219 (0.048)
Half Proof Negative	10	2155 (45.00)				
Proof Negative	10	4309 (90.00)	1	0.152 (0.006)	0.025 (0.001)	1.219 (0.048)

**Note #4:** *Deflection/Set measurements taken between anchors*



Test Results: Specimen 4: 2438 mm (96.00") x 3048 mm (120.00") KONA 3800 Series Aluminum Fixed Window Class LC- PG65 2438 x 3048 (96 x 120) Type FW

The test results are tabulated as follows:

<u>Paragraph</u>	<u>Title of Test – Test Method</u>	<u>Results</u>	<u>Allowed</u>
5.3.2.1	Air Leakage Resistance per ASTM E283	<i>See Specimen 5 for these results.</i>	
Note #1:	<i>The tested specimen meets (or exceeds) the performance levels specified in AAMA/WDMA/CSA 101/I.S.2/A440-08 (A440 S1-09) for air infiltration/exfiltration.</i>		
5.3.3.2	Water Penetration Resistance per ASTM E547		See Note #2
5.3.4.2	Uniform Load Deflection Test @ Design per ASTM E330		See Note #2
5.3.4.3	Uniform Load Structural Test @ 150% of Design Pressure per ASTM E330		See Note #2
Note #2:	<i>The client opted to start at a pressure higher than the minimum required. Those results are listed under "Optional Performance".</i>		
5.3.5	Forced-entry Resistance Test per ASTM F588	<i>See Specimen 5 for these results.</i>	

Optional Performance

4.3.2.1 Water Penetration Resistance per ASTM E547 - *See Specimen 5 for these results.*

The test results are tabulated as follows:

4.3.2.1 Uniform Load Deflection per ASTM E330  
 4.3.2.1 Uniform Load Deflection per ASTM E330

Range Allowable	Time (seconds)	Load Pa (psf)	Location mm (in.)	Deflection mm (in.)	
Half Test Positive	10	1556 (32.50)			
Test Positive	10	3112 (65.00)	1	11.913 (0.469)	See Note #3
Half Test Negative	10	1556 (32.50)			
Test Negative	10	3112 (65.00)	1	11.303 (0.445)	See Note #3

Note #3: *The deflections reported are not limited by AAMA/WDMA/CSA101/I.S.2/A440-08 (A440 S1-09) for this product designation. The deflection data is recorded in this report for special code compliance and information only*

Test Results Continued – (Specimen 4)

Range	Time (Seconds)	Load Pa (psf)	Location	Deflection mm(in.)	Set mm(in.)	Allowable mm(in.)
Half Proof Positive	10	2334 (48.75)	1	17.475 (0.688)	0.432 (0.017)	9.449 (0.372)
Proof Positive	10	4668 (97.50)				
Half Proof Negative	10	2334 (48.75)	1	17.348 (0.683)	0.127 (0.005)	9.449 (0.372)
Proof Negative	10	4668 (97.50)				

Note #4: *Deflection/Set measurements taken between anchors*

**Test Results: Specimen 5: 3048 mm (120.00") x 2438 mm (96.00") KONA 3800 Series Aluminum Fixed Windows  
Class LC- PG65 3048 x 2438 (120 x 96) Type FW**

The test results are tabulated as follows:

<u>Paragraph</u>	<u>Title of Test – Test Method</u>	<u>Results</u>	<u>Allowed</u>
5.3.2.1	Air Leakage Resistance per ASTM E283 @ 75 Pa (1.57 psf)	0.000 L/s/m <sup>2</sup> 0.000 scfm/ft <sup>2</sup>	1.50 L/s/m <sup>2</sup> (0.30 SCFM/FT <sup>2</sup> )
	Air Infiltration per ASTM E283 @ 299 Pa (6.24 psf)	0.000 L/s/m <sup>2</sup> (0.000 SCFM/FT <sup>2</sup> )	1.50 L/s/m <sup>2</sup> (0.30 SCFM/FT <sup>2</sup> )
	Air Exfiltration per ASTM E283 @ 75 Pa (1.57 psf)	0.000 L/s/m <sup>2</sup> (0.000 SCFM/FT <sup>2</sup> )	1.50 L/s/m <sup>2</sup> (0.30 SCFM/FT <sup>2</sup> )
	Air Exfiltration per ASTM E283 @ 299 Pa (6.24 psf)	0.000 L/s/m <sup>2</sup> (0.000 SCFM/FT <sup>2</sup> )	1.50 L/s/m <sup>2</sup> (0.30 SCFM/FT <sup>2</sup> )

**Note #1:** *The tested specimen meets (or exceeds) the performance levels specified in AAMA/WDMA/CSA 101/I.S.2/A440-08 (A440 S1-09) for air infiltration/exfiltration.*

5.3.3.2 Water Penetration Resistance per ASTM E547 See Note #2

5.3.4.2 Uniform Load Deflection Test @ Design per ASTM E330 See Note #2

5.3.4.3 Uniform Load Structural Test @ 150% of Design Pressure per ASTM E330 See Note #2

**Note #2:** *The client opted to start at a pressure higher than the minimum required. Those results are listed under "Optional Performance".*

5.3.5	Forced-entry Resistance Test per ASTM F588		
	Type: D                      Grade: 10		
	Disassembly Test	No Entry	No Entry

**Optional Performance**

4.3.2.1	Water Penetration Resistance per ASTM E547 @ 718 Pa (15.0 psf)	No Leakage	No Leakage
---------	---	------------	------------

Test Results: (Continued Spec 5)

The test results are tabulated as follows:

4.3.2.1 Uniform Load Deflection per ASTM E330

Range Allowable	Time (seconds)	Load Pa (psf)	Location mm (in.)	Deflection mm (in.)	
Half Test Positive	10	1556 (32.50)			
Test Positive	10	3112 (65.00)	1	10.309 (0.409)	See Note #3
Half Test Negative	10	1796 (37.50)			
Test Negative	10	3591 (75.00)	1	11.684 (0.460)	See Note #3

**Note #3:** *The deflections reported are not limited by AAMA/WDMA/CSA101/I.S.2/A440-08 (A440 S1-09) for this product designation. The deflection data is recorded in this report for special code compliance and information only*

Range	Time (Seconds)	Load Pa (psf)	Location	Deflection mm(in.)	Set mm(in.)	Allowable mm(in.)
Half Proof Positive	10	2334 (48.75)				
Proof Positive	10	4668 (97.50)	1	14.808 (0.583)	0.051 (0.002)	9.449 (0.372)
Half Proof Negative	10	2699 (56.25)				
Proof Negative	10	5387 (112.50)	1	15.494 (0.610)	0.127 (0.005)	9.449 (0.372)

**Note #4:** *Deflection/Set measurements taken between anchors*

## Conditions, Terms, and General Notes Regarding These Tests

The product tested Has Been compared to the detailed drawing, bill of materials and fabrication information supplied by the client so named herein. Our analysis, which includes dimensional and component description comparisons, indicate the tested product and engineering information supplied by the client "Are Equivalent". The report and representative samples will be retained for four years from the date of initial test.

These test results were obtained by employing all requirements of the designated test methods with no Deviations unless explicitly noted in test report. The test results and specimen supplied for testing are in compliance with the reference.

The test results are specific to the product tested by this laboratory and of the sample supplied by the client named herein, and they relate to no other product either manufactured by the client, a fabricator of the client or of the client or of installed field performance.

This test report does not constitute certification of this product, but only that the above test results were obtained using the designated test methods and they indicate compliance with the performance requirements (paragraphs as listed) of the above referenced specifications.

Testing Evaluation Laboratories, Inc. makes no opinions or endorsements regarding this product and its performance. This report may not be reproduced or quoted in partial form without the expressed written approval of Testing Evaluation Laboratories, Inc.

Testing Evaluation Laboratories, Inc.'s letter, reports, its name or insignia or mark are for the exclusive use of the client so named herein and any other use is strictly prohibited. The report, letters and the name of Testing Evaluation Laboratories, Inc., its seal or mark shall not be used in any circumstance to the general public or in any advertising.

**Limitation of liability:** Due diligence was used in performing the tests and reporting the results. By acceptance of this report, this client agrees to hold harmless and indemnify Testing Evaluation Laboratories, Inc., its employees, sub-contractors and officers and owners against all claims and demands of any kind whatsoever, which arise out of or in any manner connected with the performance of work referred to herein.

Testing Evaluation Laboratories, Inc.



Vivian K. Wright,  
President



Revision Log

<b>Rev No.</b>	<b>Date</b>	<b>Page(s)</b>	<b>Revision(s)</b>
<b>0</b>	<b>3/21/2014</b>	<b>NA</b>	<b>Original Report Issue</b>
<b>1</b>	<b>6/10/2014</b>	<b>NA</b>	<b>Report Pages 3, 4, 5, 6, 7, 8, 9 and 10 , Revised Notes 1 and 3 to reference Canadian Supplement (A440 S1-09)</b>

**TABLE OF CONTENTS**

SHEET #	DESCRIPTION
1	Table of contents
2	Test elevation
3	Horizontal and vertical cross sections
4	Frame anchoring
5	Bill of materials, components and glazing detail

Testing Evaluation Laboratories Inc  
 Specimen Complies with Drawing  
 Deviations Noted, TEL # 01991907  
 Date 3/21/14 verified by *[Signature]*

PRODUCT:		FLEETWOOD	
PART OR ASSEMBLY:		TABLE OF CONTENTS	
NO.	DATE	BY	REVISIONS
			
DATE: 9/25/13			
SCALE: N.T.S.			
DWG. BY: JK			
CHK. BY: LFS			
DRAWING NO.:			
L-7030			
SHEET <u>1</u> OF <u>5</u>			

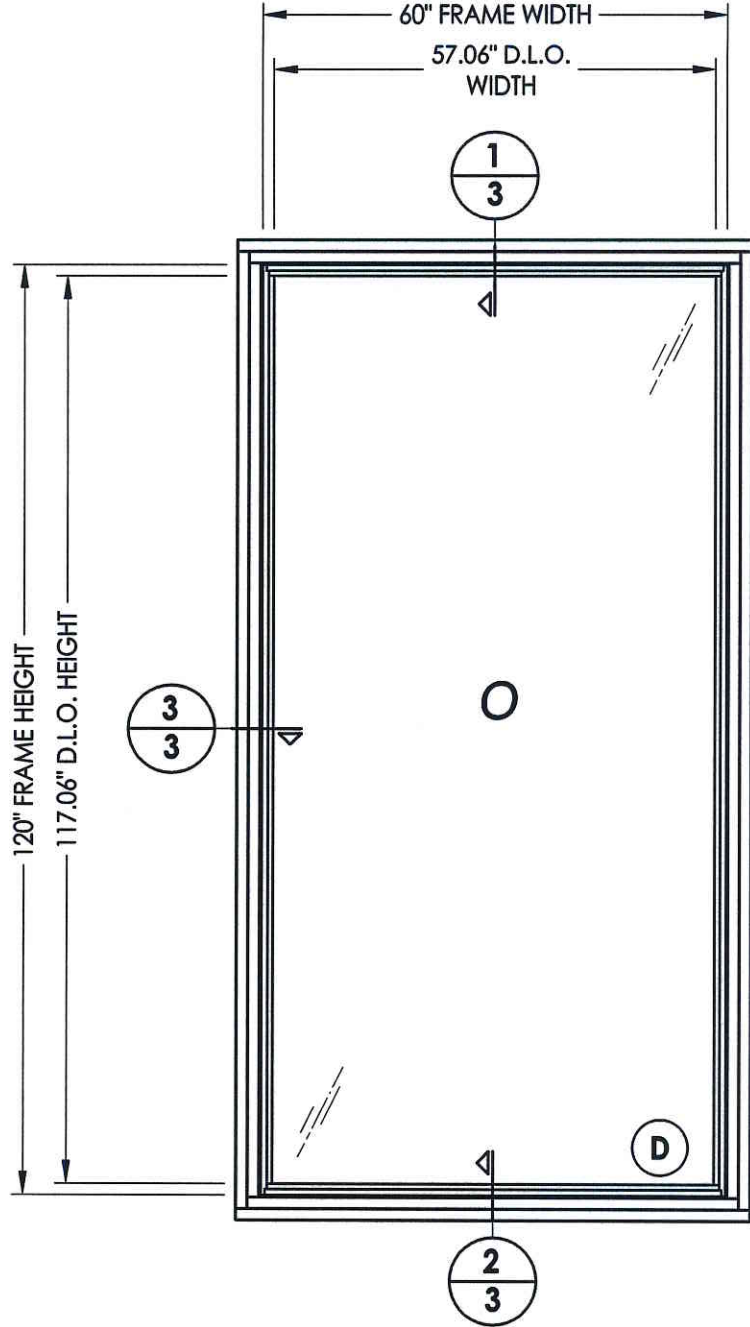

**SPEC. #1, 1A, 1B, 1C**

Testing Evaluation Laboratories Inc  
Specimen Complies with Drawing

Deviations Noted - TEL # 919.999.0007

Date 3/21/14 Verified by *[Signature]*

**RW** BUILDING  
CONSULTANTS, INC.  
813.659.9197

DATE:	9/25/13
SCALE:	N.T.S.
DWG. BY:	JK
CHK. BY:	LFS
DRAWING NO.:	L-7030
SHEET	<u>2</u> OF <u>5</u>

PRODUCT:	FLEETWOOD		
PART OR ASSEMBLY:	TEST ELEVATIONS		
NO.	DATE	BY	REVISIONS

**3** **HORIZONTAL CROSS SECTION**

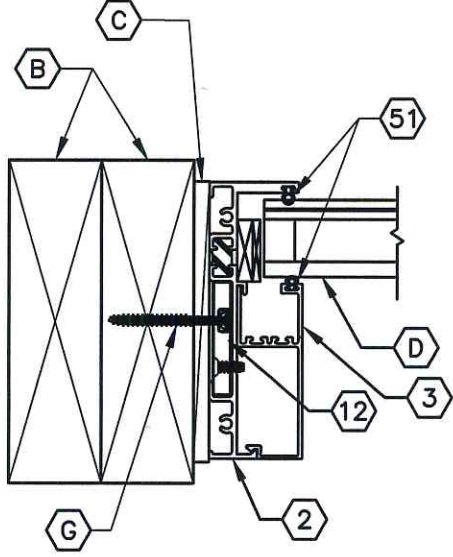

**2** **VERTICAL CROSS SECTION**

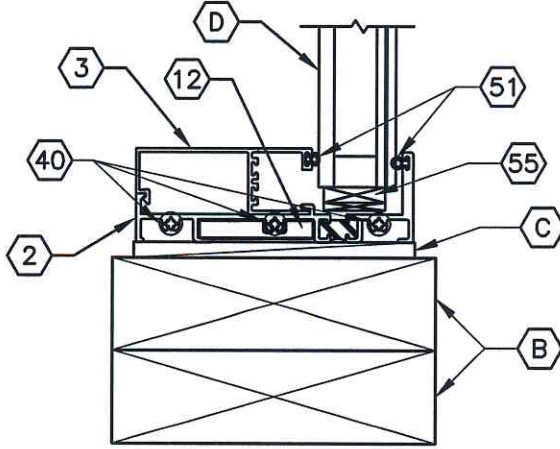

**1** **VERTICAL CROSS SECTION**

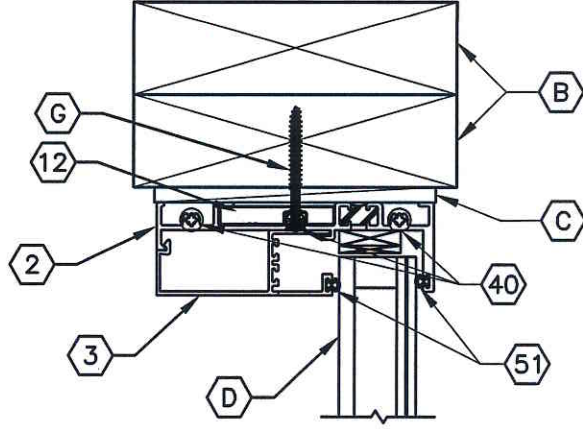

Testing Evaluation Laboratories Inc  
 Specimen Complies with Drawing  
 Deviations Noted TEL # 0199 1007  
 Date 3/21/14 Verified by *[Signature]*

**RW** BUILDING  
 CONSULTANTS, INC.  
 813.659.9197

DATE: 9/25/13  
 SCALE: N.T.S.  
 DWG. BY: JK  
 CHK. BY: LFS  
 DRAWING NO.:  
 L-7030  
 SHEET 3 OF 5

PRODUCT:		FLEETWOOD	
PART OR ASSEMBLY:		VERTICAL AND HORIZONTAL CROSS SECTIONS	
NO.	DATE	BY	REVISIONS

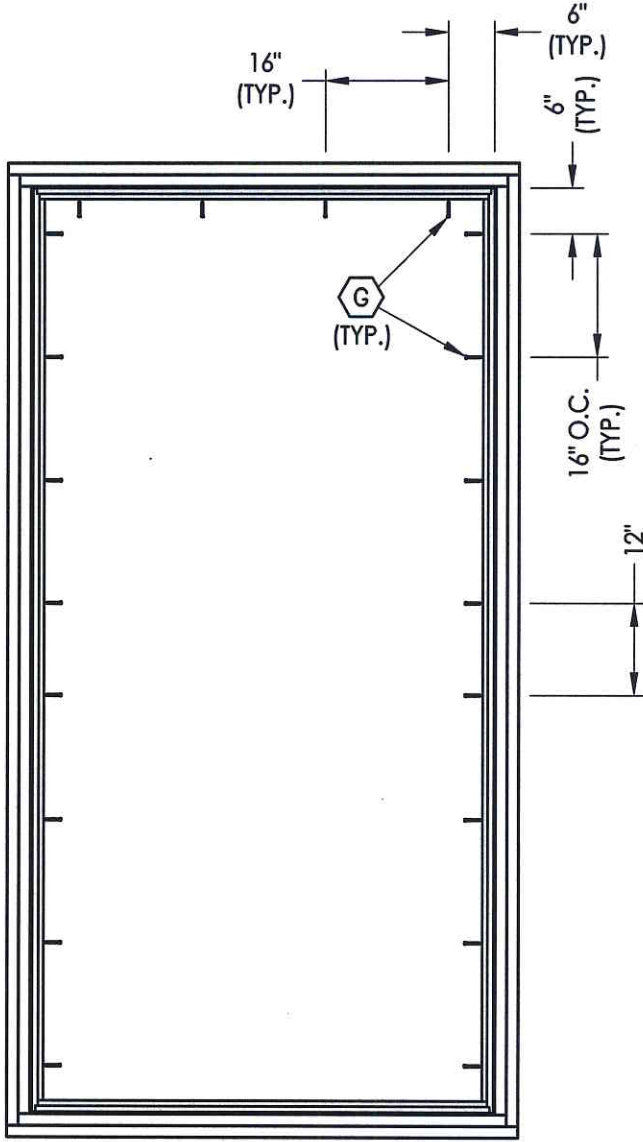

**FRAME ANCHORING**  
2X buck construction

Testing Evaluation Laboratories Inc  
Specimen Complies with Drawing  
Deviations Noted - TEL # 0199 1807  
Date 3/21/14 Verified by *[Signature]*

**RW** BUILDING  
CONSULTANTS, INC.  
813.659.9197

DATE: 9/25/13

SCALE: N.T.S.

DWG. BY: JK

CHK. BY: LFS

DRAWING NO.:  
L-7030

SHEET 4 OF 5

PRODUCT:		FLEETWOOD
PART OR ASSEMBLY:		FRAME ANCHORING
NO.	DATE	BY
REVISIONS		



**BILL OF MATERIALS**

ITEM #	DESCRIPTION	MATERIAL
B	2X BUCK SG >= 0.55	WOOD
C	1/4" MAX. SHIM SPACE	-
G	#10 x 2" PFH WOOD SCREW	STEEL
2	KONA BLOCK FRAME	6063-T6 ALUM
3	GLASS STOP (1-1/4")	6063-T6 ALUM
12	SHEAR BLOCK	ALUM
40	#10 X 1" PPH SMS	STEEL
51	MINI BULB VINYL (EPDM 70 DUROMETER)-TREMCO	-
55	SETTING BLOCK	-

Testing Evaluation Laboratories Inc  
 Specimen Complies with Drawing  
 Deviations Noted - TEL # 01991007  
 Date 3/21/14 Verified by *[Signature]*

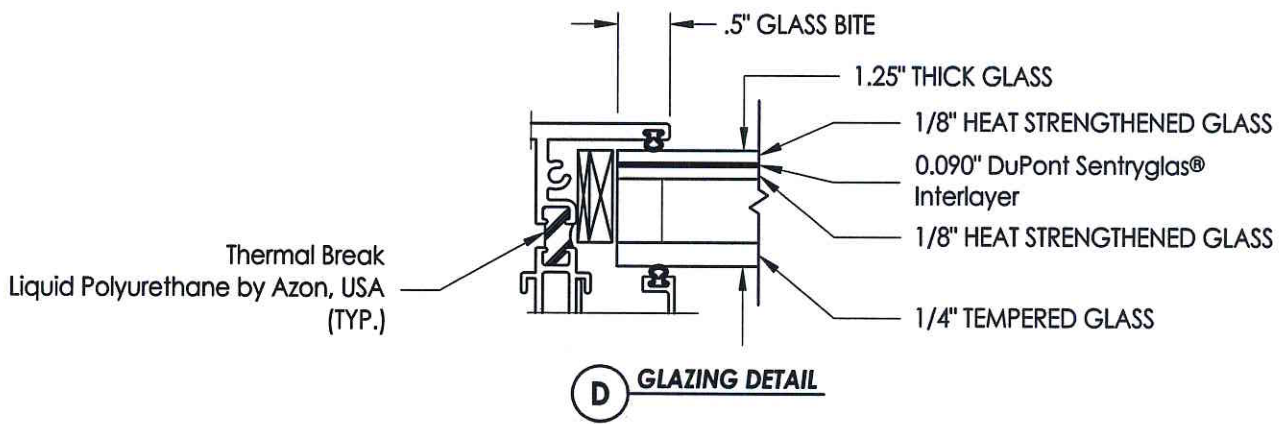
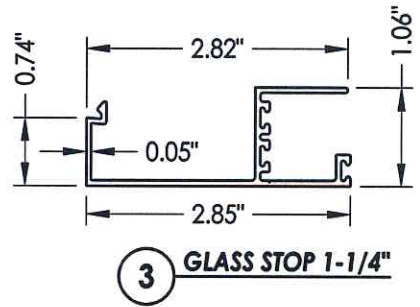
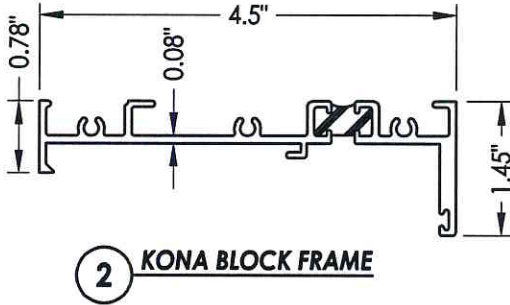

PRODUCT: FLEETWOOD	
PART OR ASSEMBLY: BILL OF MATERIALS, COMPONENTS AND GLAZING DETAIL	
NO.	DATE
BY	REVISIONS
 R.W. BUILDING CONSULTANTS, INC. 813.659.9197	
DATE: 9/25/13	
SCALE: N.T.S.	
DWG. BY: JK	
CHK. BY: LFS	
DRAWING NO.: L-7030	
SHEET 5 OF 5	

TABLE OF CONTENTS	
SHEET #	DESCRIPTION
1	Table of contents
2	Test elevation
3	Test elevation
4	Horizontal and vertical cross sections
5	Frame anchoring
6	Frame anchoring
7	Components and glazing detail
8	Bill of materials

Testing Evaluation Laboratories Inc  
 Specimen Complies with Drawing  
 Deviations Noted - TEL # 0199-1807  
 Date 3/21/14 Verified by *[Signature]*



DATE: 1/14/14  
 SCALE: N.T.S.  
 DWG. BY: JK  
 CHK. BY: LFS  
 DRAWING NO.: L-7108  
 SHEET 1 OF 8

PRODUCT:	FLEETWOOD		
PART OR ASSEMBLY:	TABLE OF CONTENTS		
NO.	DATE	BY	REVISIONS

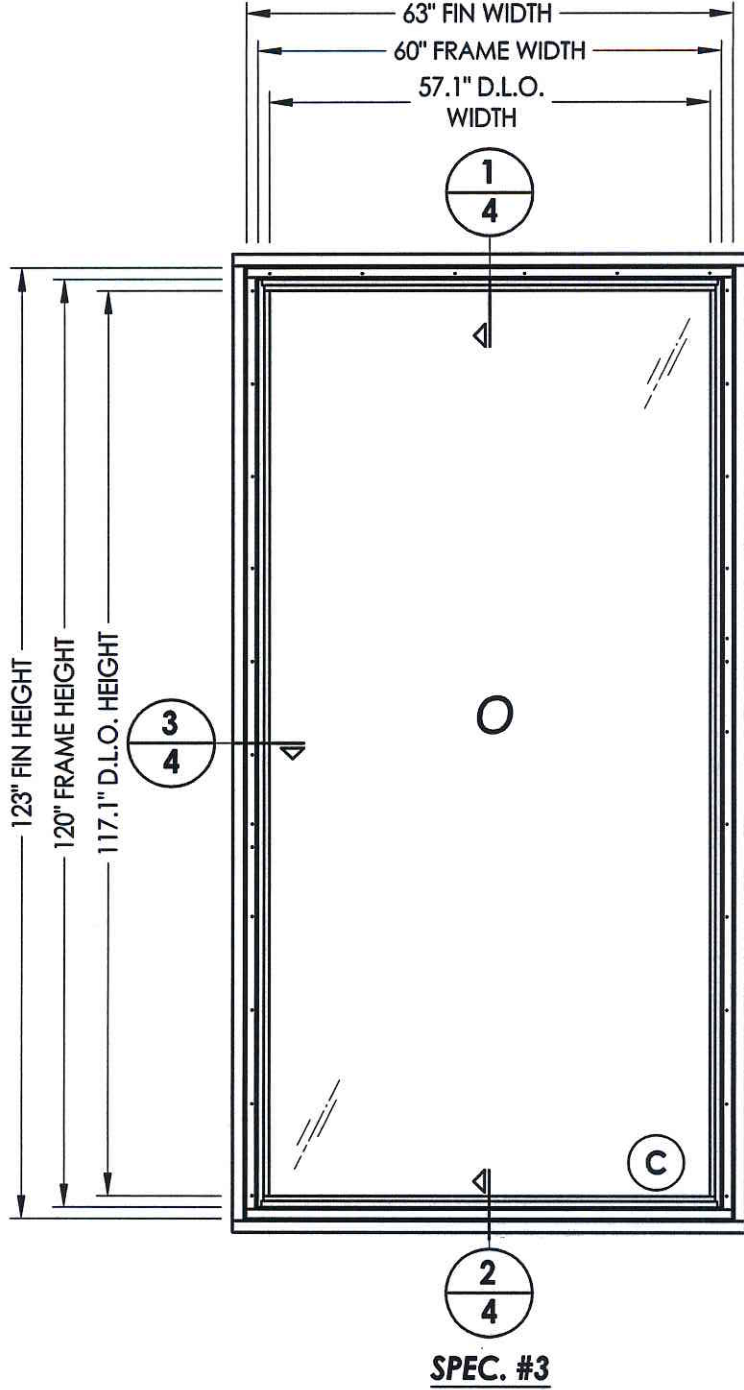

Testing Evaluation Laboratories Inc  
Specimen Complies with Drawing  
Deviations Noted - TEL # 0199 1007  
Date 3/21/14 Verified by WJW

PRODUCT:		FLEETWOOD	
PART OR ASSEMBLY:		TEST ELEVATIONS	
NO.	DATE	REVISIONS	BY
			
DATE: 1/14/14			
SCALE: N.T.S.			
DWG. BY: JK			
CHK. BY: LFS			
DRAWING NO.: L-7108			
SHEET 2 OF 8			

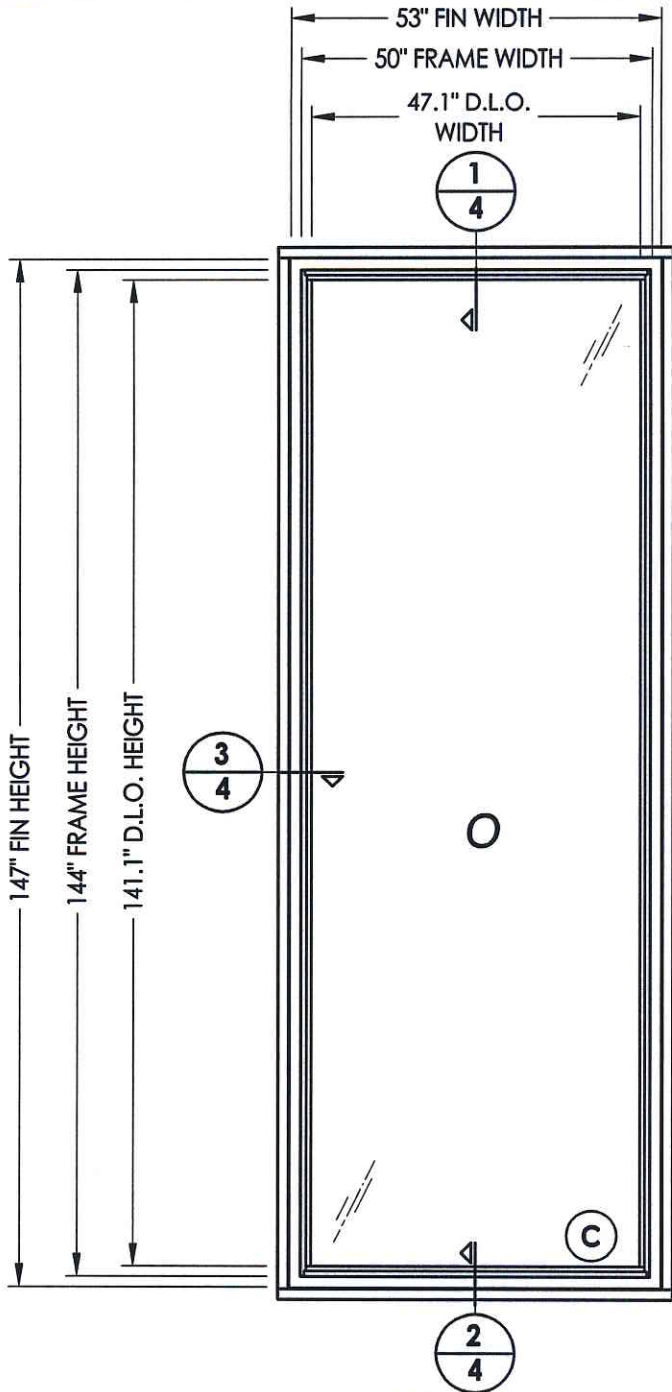

**SPEC. #2, 2A**

Testing Evaluation Laboratories Inc  
 Specimen Complies with Drawing  
 Deviations Noted - TEL # 01991007  
 Date 3/21/14 Verified by *elw*



DATE: 1/14/14  
 SCALE: N.T.S.  
 DWG. BY: JK  
 CHK. BY: LFS  
 DRAWING NO.: L-7108  
 SHEET 3 OF 8

PRODUCT: FLEETWOOD	
PART OR ASSEMBLY: TEST ELEVATION	
NO.	DATE
BY	REVISIONS



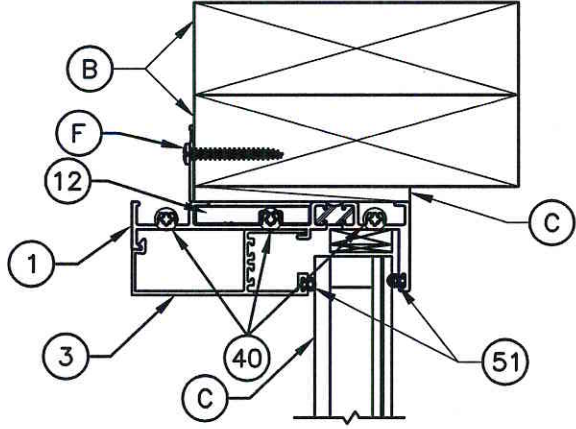

**1**  
**4** VERTICAL CROSS SECTION

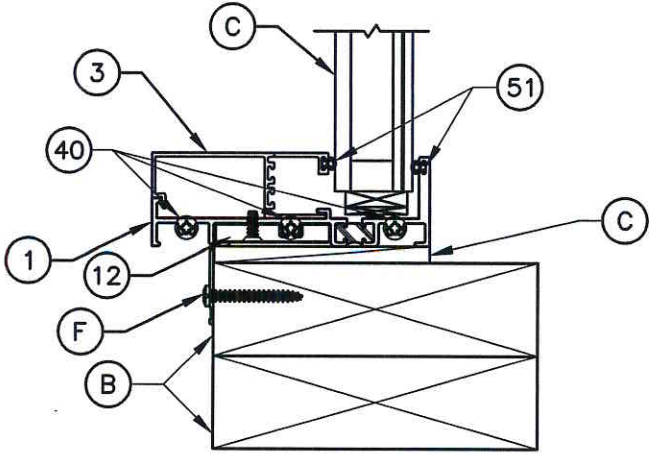

**2**  
**4** VERTICAL CROSS SECTION

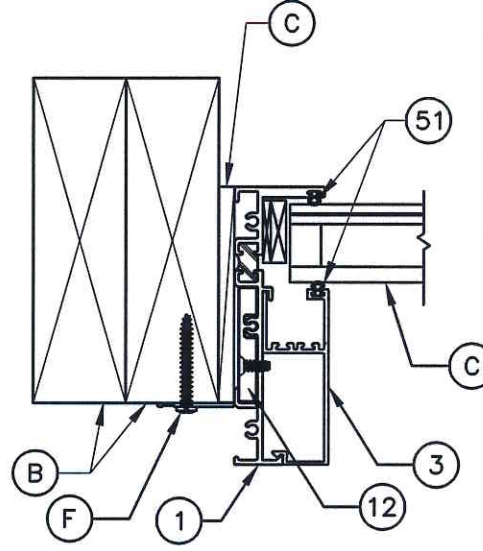

**3**  
**4** HORIZONTAL CROSS SECTION

Testing Evaluation Laboratories Inc  
 Specimen Complies with Drawing  
 Deviations Noted - TEL # 01991007  
 Date 3/11/14 Verified by JJK

PRODUCT:		FLEETWOOD	
PART OR ASSEMBLY:		VERTICAL AND HORIZONTAL CROSS SECTIONS	
NO.	DATE	BY	REVISIONS
RW BUILDING CONSULTANTS, INC. 813.659.9197			
DATE: 1/14/14			
SCALE: N.T.S.			
DWG. BY: JK			
CHK. BY: LFS			
DRAWING NO.: L-7108			
SHEET 4 OF 8			



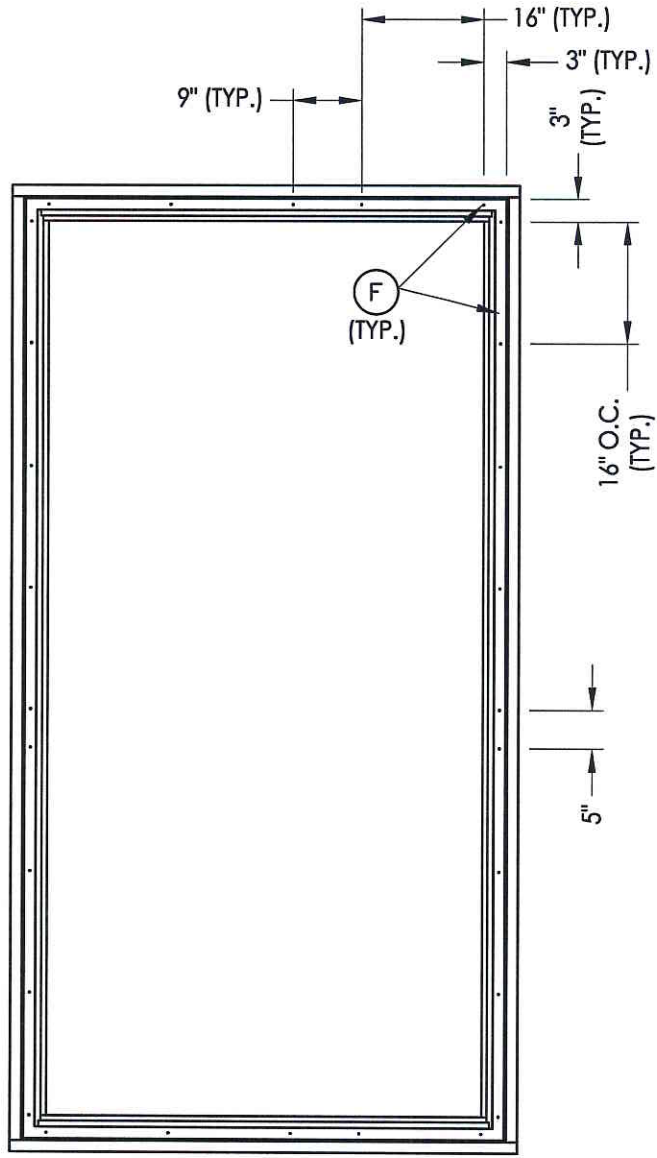

**FRAME ANCHORING W/ FIN**  
2X buck construction

Testing Evaluation Laboratories Inc  
 Specimen Complies with Drawing  
 Deviations Noted - TEL # 819.911.0007  
 Date 3/21/14 Verified by ELLW

**RW** BUILDING  
 CONSULTANTS, INC.  
 813.659.9197

DATE: 1/14/14  
 SCALE: N.T.S.  
 DWG. BY: JK  
 CHK. BY: LFS  
 DRAWING NO.:  
 L-7108  
 SHEET 5 OF 8

PRODUCT: FLEETWOOD	
PART OR ASSEMBLY: FRAME ANCHORING	
NO.	DATE
	BY
REVISIONS	

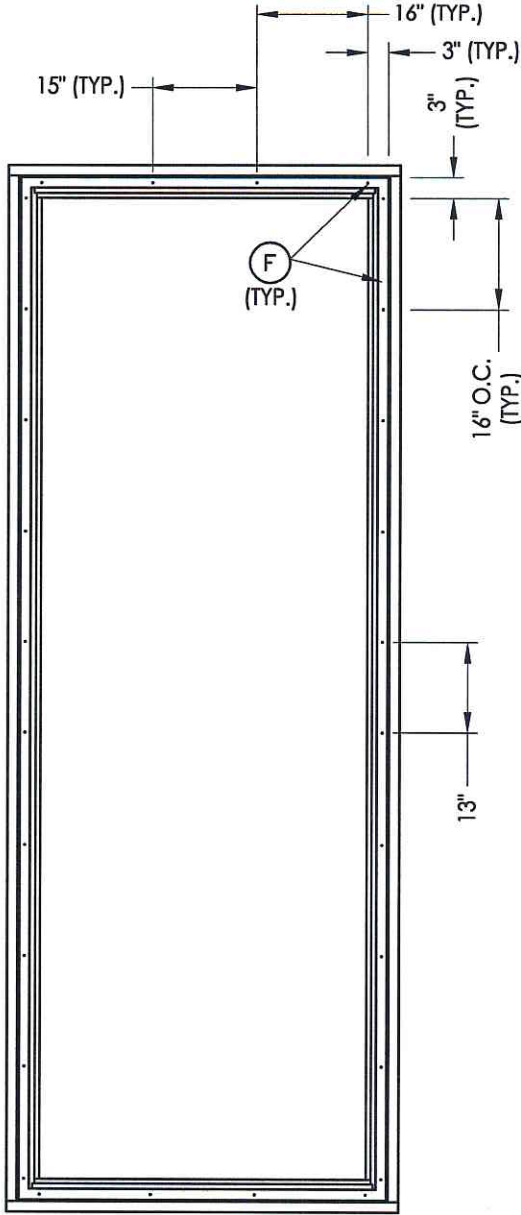

**FRAME ANCHORING W/ FIN**  
2X buck construction

Testing Evaluation Laboratories Inc  
Specimen Complies with Drawing  
Deviations Noted - TEL # 01999007  
Date 3/21/14 verified by *elcaw*

PRODUCT: FLEETWOOD		
PART OR ASSEMBLY: FRAME ANCHORING		
NO.	DATE	BY
REVISIONS		

**R.W.** BUILDING CONSULTANTS, INC.  
813.659.9197

DATE: 1/14/14  
SCALE: N.T.S.  
DWG. BY: JK  
CHK. BY: LFS  
DRAWING NO.: L-7108  
SHEET 6 OF 8

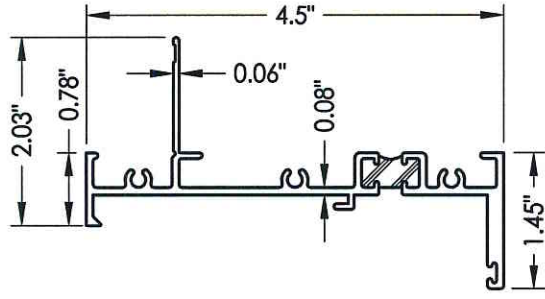

**1 KONA FIN FRAME**

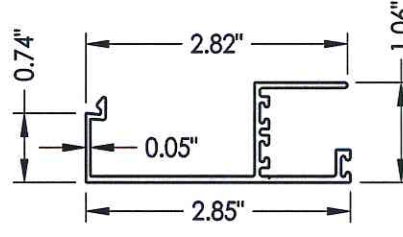

**3 GLASS STOP 1-1/4"**

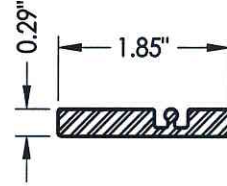

**12 SHEAR BLOCK**

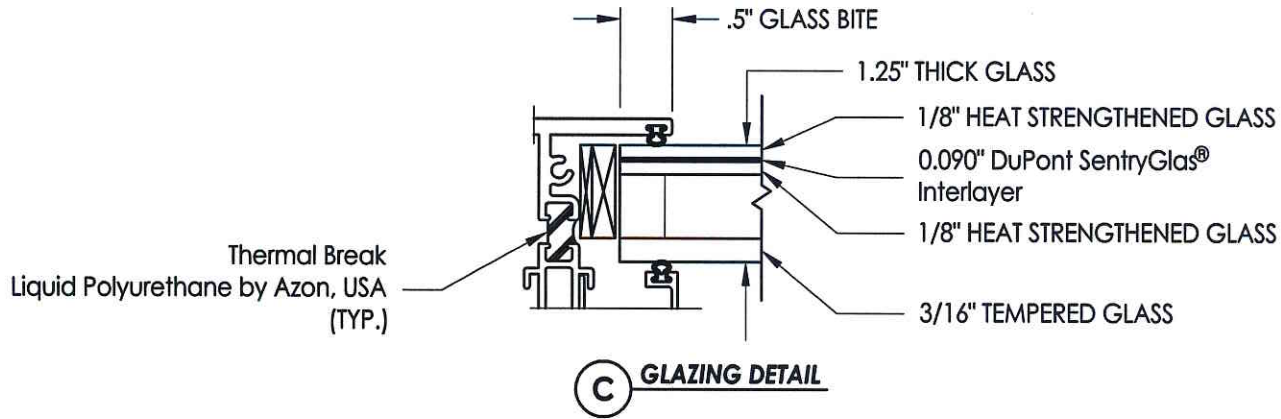

**C GLAZING DETAIL**

Testing Evaluation Laboratories Inc  
 Specimen Complies with Drawing  
 Deviations Noted TEL #01991007  
 Date 3/21/14 Verified by *[Signature]*

PRODUCT:		FLEETWOOD	
PART OR ASSEMBLY:		COMPONENTS AND GLAZING DETAILS	
NO.	DATE	BY	REVISIONS
DATE: 1/14/14			
SCALE: N.T.S.			
DWG. BY: JK			
CHK. BY: LFS			
DRAWING NO.: L-7108			
SHEET 7 OF 8			

BILL OF MATERIALS		
ITEM #	DESCRIPTION	MATERIAL
B	2X BUCK SG >= 0.55	WOOD
C	1/4" MAX. SHIM SPACE	-
G	#10 x 2" PFH WOOD SCREW	STEEL
F	#10 x 1-1/2" PPH WOOD SCREW	STEEL
1	KONA FIN FRAME	6063-T6 ALUM
3	GLASS STOP (1-1/4")	6063-T6 ALUM
12	SHEAR BLOCK	ALUM
40	#10 X 1" PPH SMS	STEEL
51	MINI BULB VINYL(EPDM 70 DUROMETER)-TREMCO	-
55	SETTING BLOCK	-

Testing Evaluation Laboratories Inc  
 Specimen Complies with Drawing  
 Deviations Noted- TEL #01991007  
 Date 3/21/14 Verified by LFS

PRODUCT:		FLEETWOOD	
PART OR ASSEMBLY:		BILL OF MATERIALS	
NO.	DATE	BY	REVISIONS
			
DATE: 1/14/14			
SCALE: N.T.S.			
DWG. BY: JK			
CHK. BY: LFS			
DRAWING NO.: L-7108			
SHEET 8 OF 8			

TABLE OF CONTENTS	
SHEET #	DESCRIPTION
1	Table of contents
2	Test elevation
3	Test elevation
4	Horizontal and vertical cross sections
5	Horizontal and vertical cross sections
6	Glazing details
7	Frame anchoring
8	Frame anchoring
9	Components
10	Bill of materials

Testing Evaluation Laboratories Inc  
 Specimen Complies with Drawing  
 Deviations Noted TEL # 0199 8007  
 Date 3/21/14 verified by *[Signature]*



DATE: 1/15/14

SCALE: N.T.S.

DWG. BY: JK

CHK. BY: LFS

DRAWING NO.:  
L-7109

SHEET 1 of 10

PRODUCT: FLEETWOOD	
PART OR ASSEMBLY: TABLE OF CONTENTS	
NO.	DATE
BY	REVISIONS





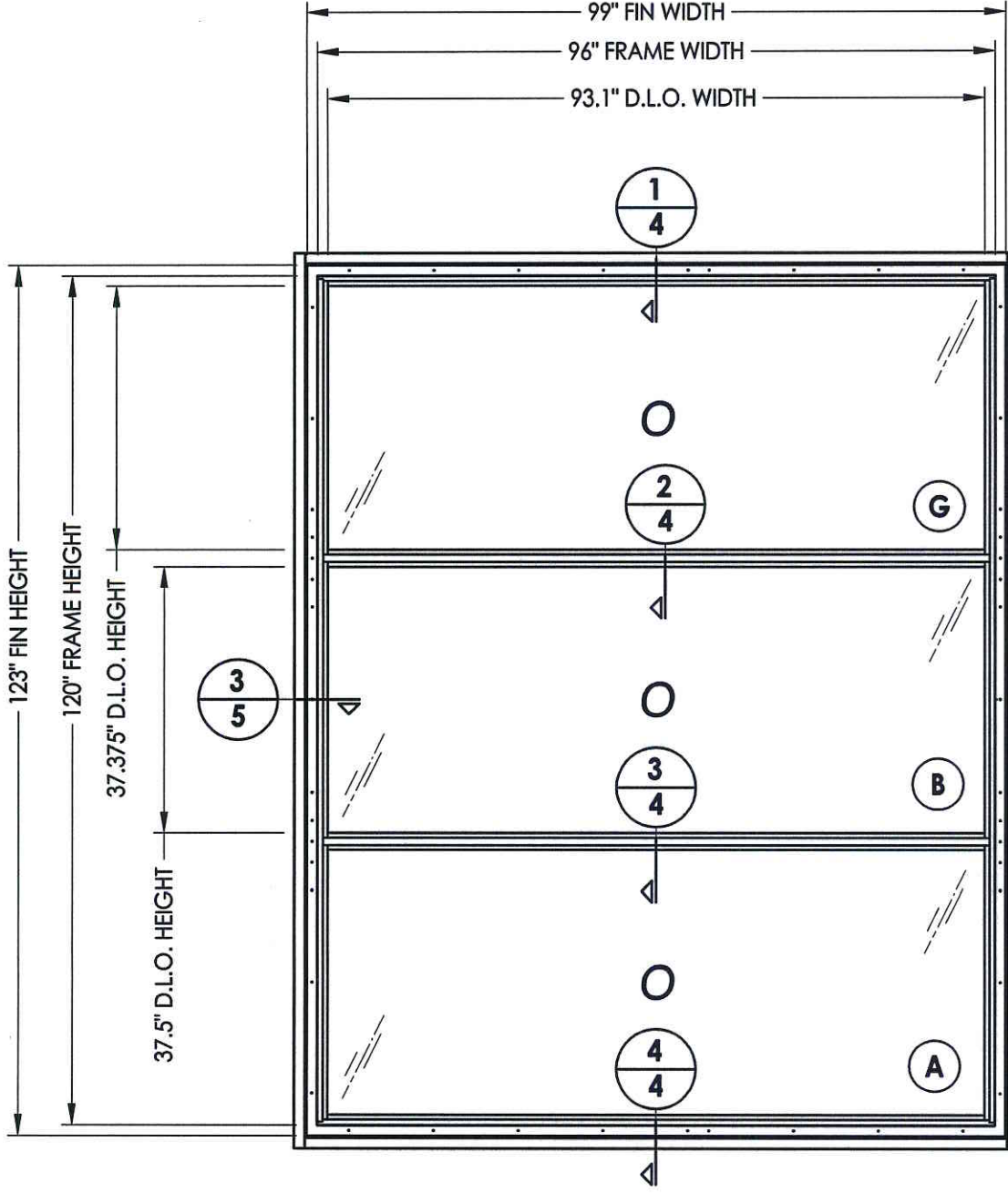

**SPEC. #4, 4A**

Testing Evaluation Laboratories Inc  
 Specimen Complies with Drawing  
 Deviations Notes - TEL # 019911007  
 Date: 3/21/14 Verified by: [Signature]

PRODUCT: FLEETWOOD	
PART OR ASSEMBLY: TEST ELEVATION	
NO.	DATE
BY	REVISIONS
<div style="border: 1px solid black; padding: 5px; display: inline-block;"> <b>RW</b> BUILDING CONSULTANTS, INC.                  813.659.9197             </div>	
DATE: 1/15/14	
SCALE: N.T.S.	
DWG. BY: JK	
CHK. BY: LFS	
DRAWING NO.: L-7109	
SHEET 3 OF 10	

NOTE:  
1. Item #11 located 6" from each end and one in center (3) total.

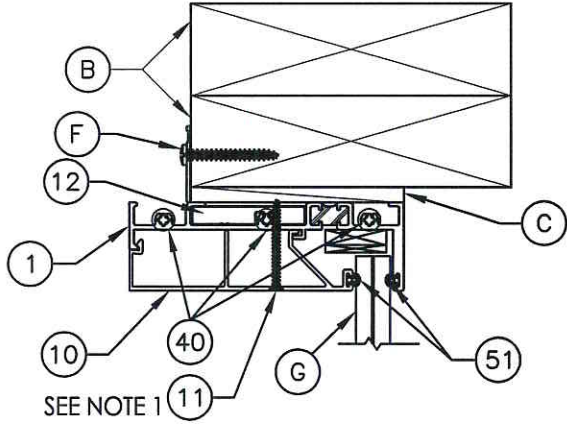

**1**  
**4** VERTICAL CROSS SECTION

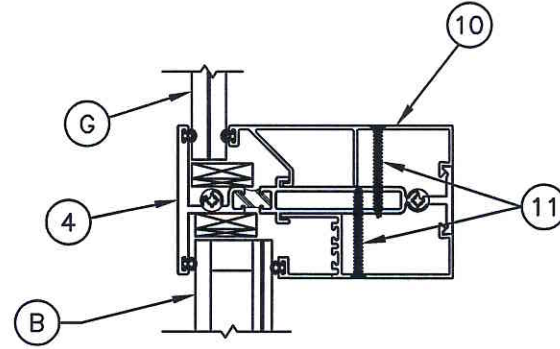

**2**  
**4** HORIZONTAL CROSS SECTION

Testing Evaluation Laboratories Inc  
Specimen Complies with Drawing  
Deviations Noted - TEL # 01991 007  
Date 3/21/14 Verified by *[Signature]*

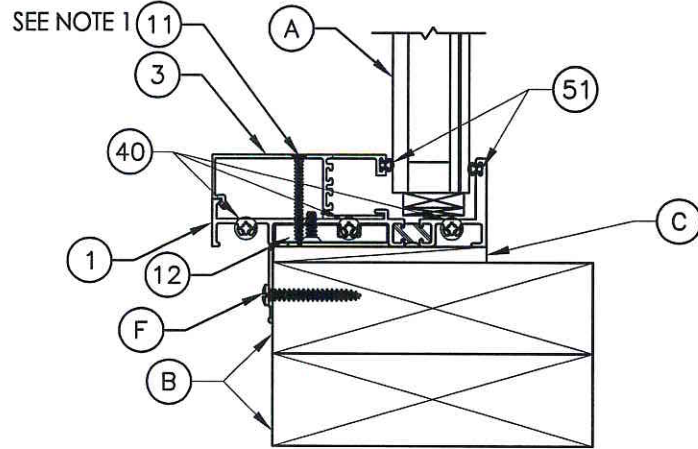

**4**  
**4** VERTICAL CROSS SECTION

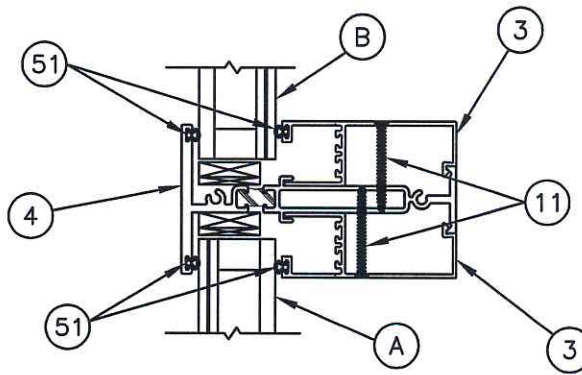

**3**  
**4** HORIZONTAL CROSS SECTION

PRODUCT: FLEETWOOD		PART OR ASSEMBLY: VERTICAL AND HORIZONTAL CROSS SECTIONS	
NO.	DATE	BY	REVISIONS
DATE: 1/15/14			
SCALE: N.T.S.			
DWG. BY: JK			
CHK. BY: LFS			
DRAWING NO.: L-7109			
SHEET 4 OF 10			



NOTE:  
 1. Item #11 located 6" from each end and one in center (3) total.

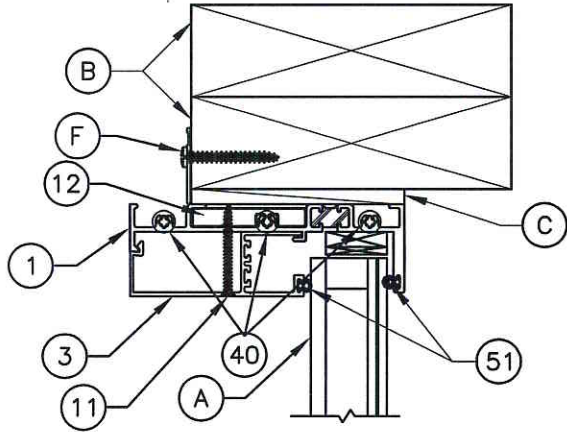

**1**  
**5** VERTICAL CROSS SECTION

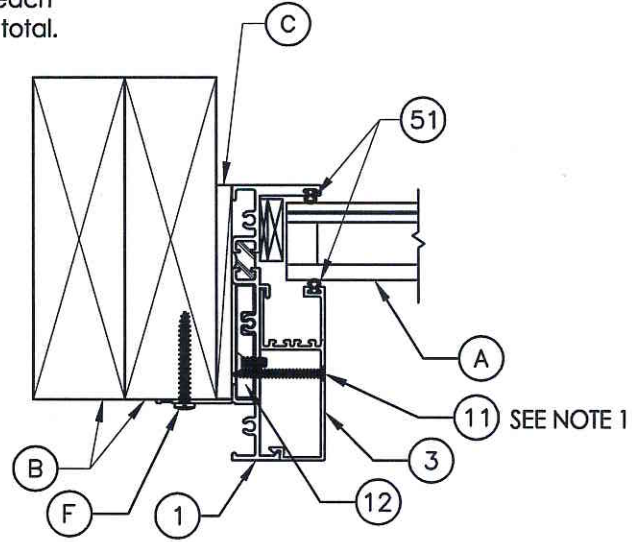

**3**  
**5** HORIZONTAL CROSS SECTION

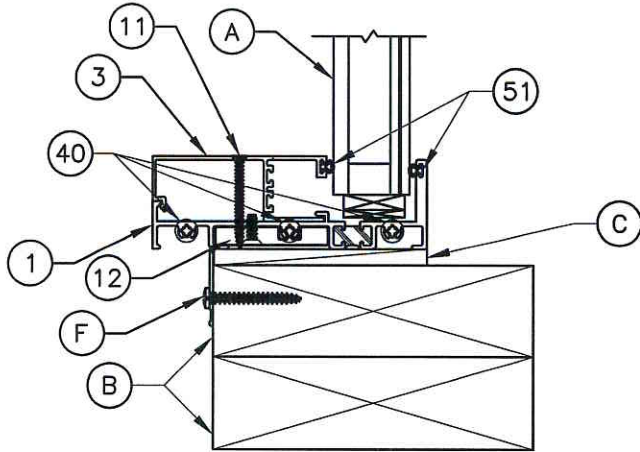

**2**  
**5** VERTICAL CROSS SECTION

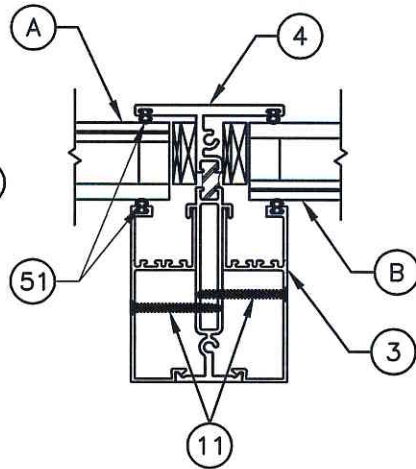

**4**  
**5** HORIZONTAL CROSS SECTION

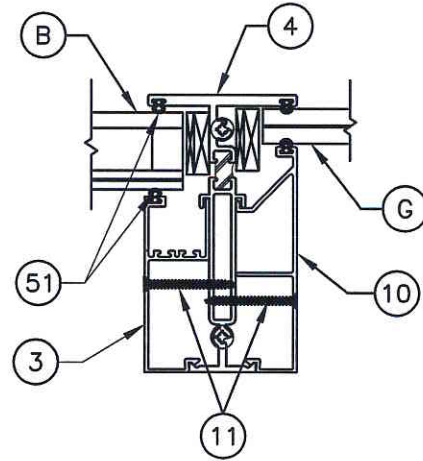

**5**  
**5** HORIZONTAL CROSS SECTION

Testing Evaluation Laboratories Inc  
 Specimen Complies with Drawing  
 Deviations Noted - TEL # 01991007  
 Date 3/21/14 Verified by [Signature]

PRODUCT:		FLEETWOOD	
PART OR ASSEMBLY:		VERTICAL AND HORIZONTAL CROSS SECTIONS	
NO.	DATE	REVISIONS	BY
 RW BUILDING CONSULTANTS, INC. 813.659.9197			
DATE: 1/15/14			
SCALE: N.T.S.			
DWG. BY: JK			
CHK. BY: LFS			
DRAWING NO.: L-7109			
SHEET 5 OF 10			

Testing Evaluation Laboratories Inc  
 Specimen Complies with Drawings  
 Deviations Noted TEL # 019911007  
 Date 3/21/14 Verified by *WFW*

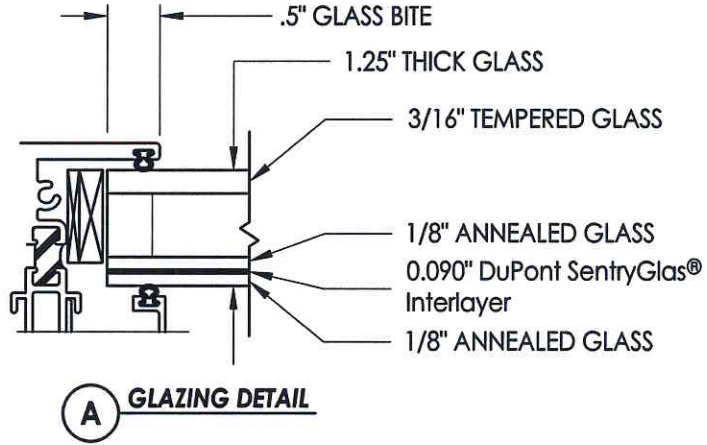
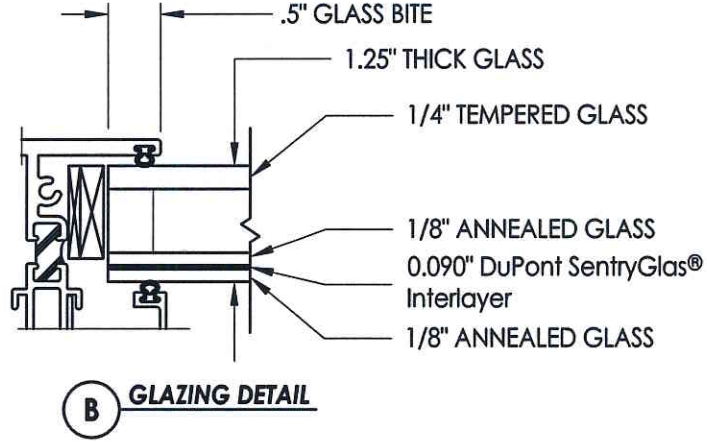
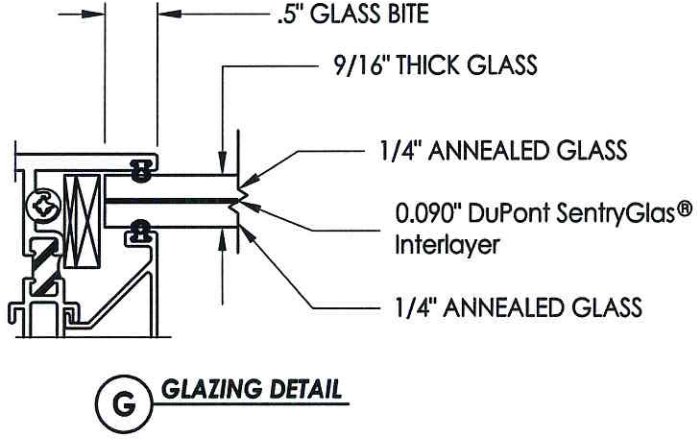

PRODUCT: FLEETWOOD		PART OR ASSEMBLY: GLAZING DETAILS	
NO.	DATE	BY	REVISIONS
DATE: 1/15/14			
SCALE: N.T.S.			
DWG. BY: JK			
CHK. BY: LFS			
DRAWING NO.: L-7109			
SHEET 6 OF 10			

Testing Evaluation Laboratories Inc  
 Specimen Complies with Drawing  
 Deviations Noted - TEL # 019991007  
 Date 3/21/14 Verified by *[Signature]*

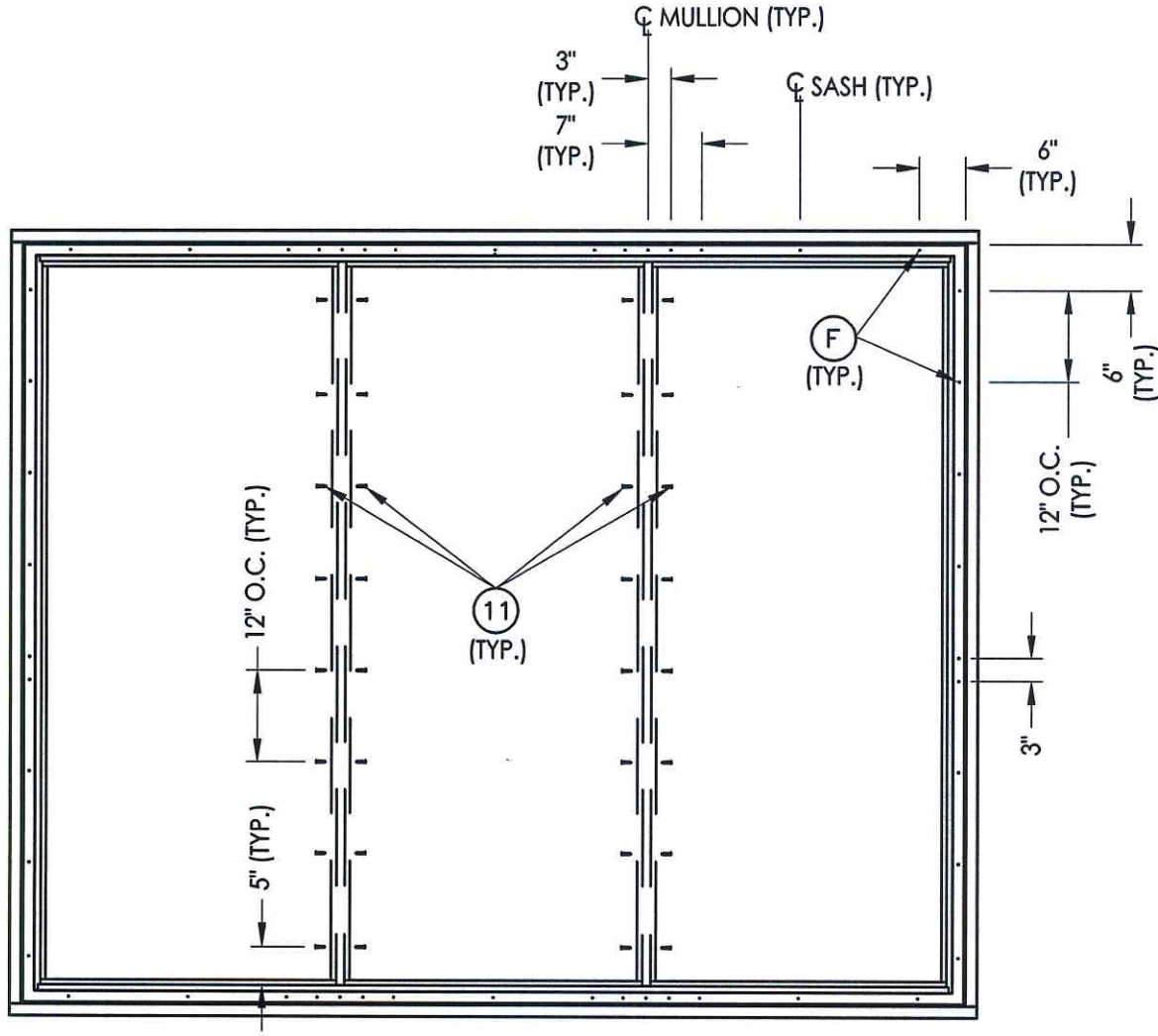

**FRAME ANCHORING W/ FIN**  
 2X buck construction

**RW** BUILDING  
 CONSULTANTS, INC.  
 813.659.9197

DATE:	1/15/14
SCALE:	N.T.S.
DWG. BY:	JK
CHK. BY:	LFS
DRAWING NO.:	L-7109
SHEET	7 OF 10

NO.	DATE	REVISIONS	BY

PRODUCT:	FLEETWOOD
PART OR ASSEMBLY:	FRAME ANCHORING



Testing Evaluation Laboratories Inc  
 Specimen Complies with Drawing #  
 Deviations Noted - TEL # 01991007  
 Date 3/24/14 Verified by *allu*

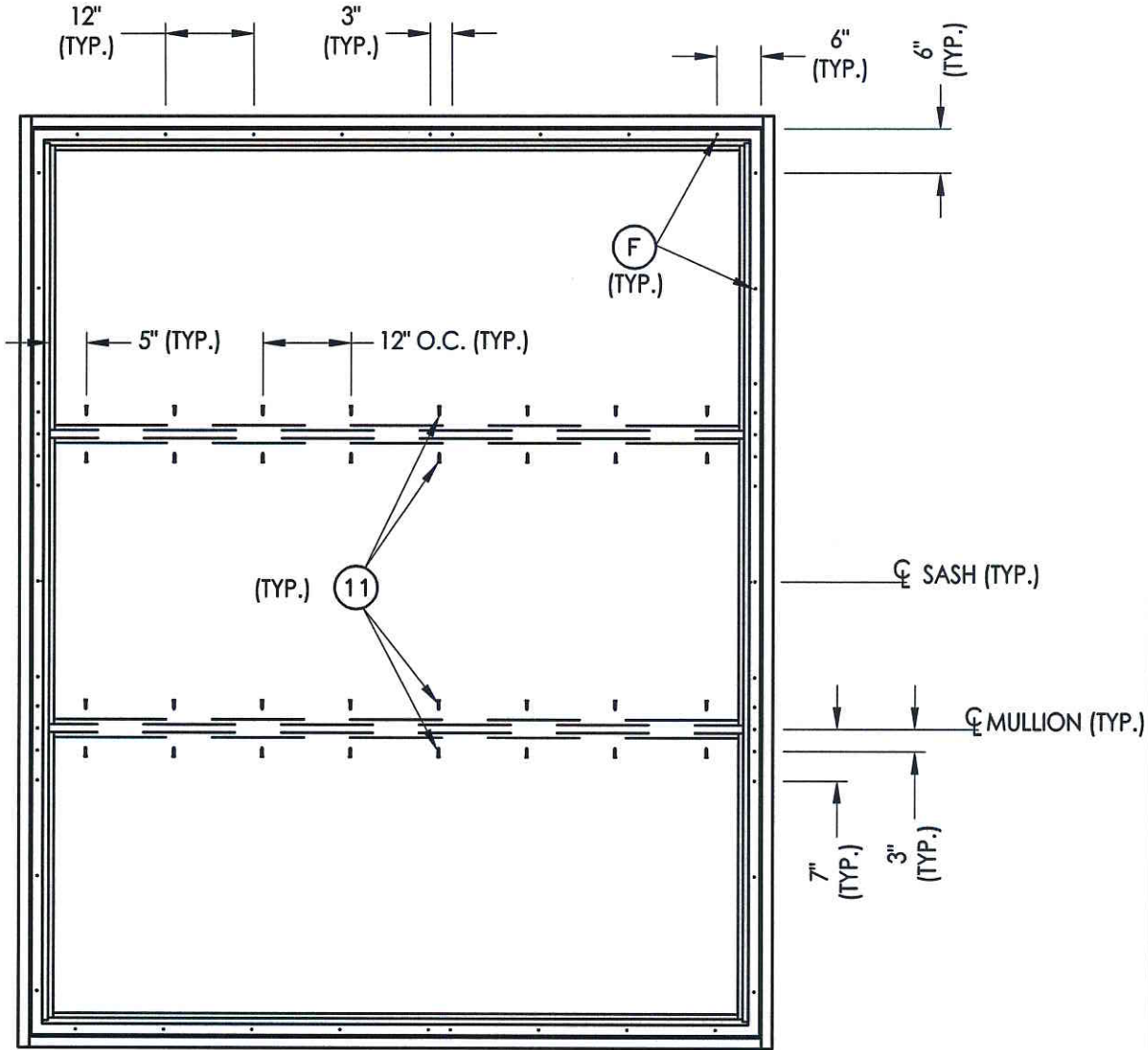

**FRAME ANCHORING W/ FIN**  
 2X buck construction

PRODUCT:		FLEETWOOD	
PART OR ASSEMBLY:		FRAME ANCHORING	
NO.	DATE	BY	REVISIONS
			
DATE: 1/15/14			
SCALE: N.T.S.			
DWG. BY: JK			
CHK. BY: LFS			
DRAWING NO.: L-7109			
SHEET 8 OF 10			

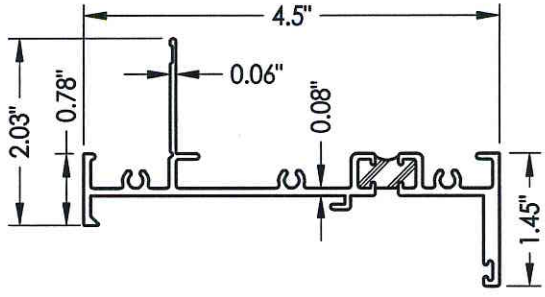

**1 KONA FIN FRAME**

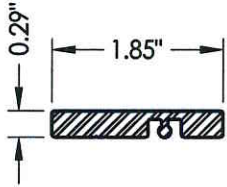

**12 SHEAR BLOCK**

Testing Evaluation Laboratories Inc  
 Specimen Complies with Drawing  
 Deviations Noted - TEL # 01991007  
 Date *11/11/10* Verified by *9/11/10*

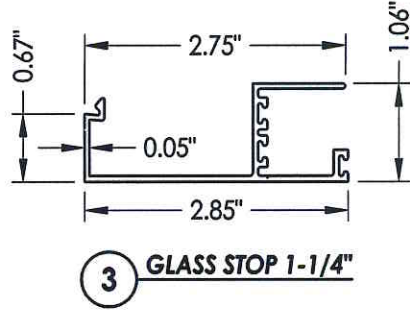

**3 GLASS STOP 1-1/4"**

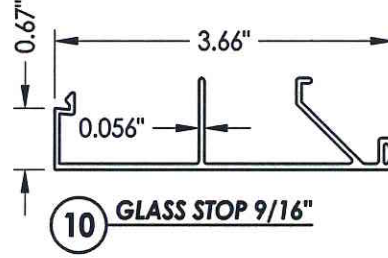

**10 GLASS STOP 9/16"**

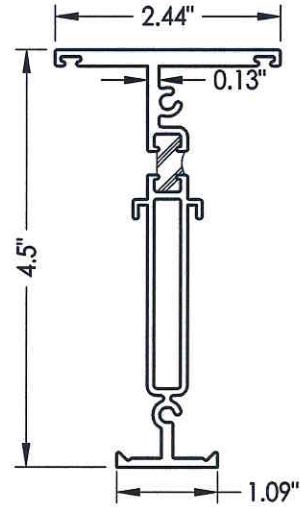

**4 MULLION**

PRODUCT:		FLEETWOOD	
PART OR ASSEMBLY:		COMPONENTS AND GLAZING DETAILS	
NO.	DATE	BY	REVISIONS
			
DATE: 1/15/14			
SCALE: N.T.S.			
DWG. BY: JK			
CHK. BY: LFS			
DRAWING NO.: L-7109			
SHEET 9 OF 10			

BILL OF MATERIALS		
ITEM #	DESCRIPTION	MATERIAL
B	2X BUCK SG >= 0.55	WOOD
C	1/4" MAX. SHIM SPACE	-
G	#10 x 2" PFH WOOD SCREW	STEEL
F	#10 x 1-1/2" PPH WOOD SCREW	STEEL
1	KONA FIN FRAME	6063-T6 ALUM
3	GLASS STOP (1-1/4")	6063-T6 ALUM
4	MULLION	6063-T6 ALUM
10	GLASS STOP (9/16")	6063-T6 ALUM
11	#8 x 1-1/2" PFH SMS	STEEL
12	SHEAR BLOCK	6061-T6 ALUM
40	#10 X 1" PPH SMS	STEEL
51	MINI BULB VINYL(EPDM 70 DUROMETER)-TREMCO	-
55	SETTING BLOCK	-

Testing Evaluation Laboratories Inc  
 Specimen Coraplies with Drawing  
 Deviations Noted - TEL. # 0199 1007  
 Date 3/21/14 verified by *[Signature]*

PRODUCT: FLEETWOOD	
PART OR ASSEMBLY: BILL OF MATERIALS	
REVISIONS	
NO.	DATE
BY	



DATE: 1/15/14  
 SCALE: N.T.S.  
 DWG. BY: JK  
 CHK. BY: LFS  
 DRAWING NO.: L-7109  
 SHEET 10 OF 10