



Testing Evaluation Laboratories, Inc.

2002 Wood Court Suite 1 – Plant City, FL 33563
Phone: 813-754-9887

ASTM E 1886-05 / ASTM E 1996-06
Missile Level “D” (Includes Wind Zone 4)

TEST REPORT SUMMARY

Test Report Issued To:

Fleetwood Windows and Doors
1 Fleetwood Way
Corona, CA 92879

WESTWOOD 250 Casement Windows

Title of Test	Results	
	Specimen 6A 42.00 x 84.00	Specimen 12A 42.00 x 72.00
Impact	Pass	Pass
Fatigue Load Cycling	+65.0/- 65.0 psf	+65.0/- 65.0 psf

Reference should be made to Report No. TEL 01991057 for complete test specimen description and data. Please see Report No. TEL 01990818 for additional impact specimens. For corresponding data regarding AAMA/WDMA/CSA 101/I.S./2/A440-08 reference should be made to Report No. TEL 01991056.

For Testing Evaluation Laboratories, Inc.

Vivian K. Wright,
President



Testing Evaluation Laboratories, Inc.

2002 Wood Court Suite 1 – Plant City, FL 33563
Phone: 813-754-9887

TEST RESULTS

IAS Laboratory Certification No: TL-299

Report No: TEL 01991057
Test Dates: September 23-27, 2013
Report Date: June 14, 2014

Issued to:

Fleetwood Windows and Doors
1 Fleetwood Way
Corona, CA 92879

Project Summary: Testing Evaluation Laboratories, Inc. (TEL) was contracted by Fleetwood Windows and Doors to perform tests on the WESTWOOD 250 Casement Windows at TEL's Plant City, FL test facility. *Please see Report No. TEL 01990818 for additional impact specimens.*

Test specimen descriptions and results are reported herein.

Test Specifications: The test specimens were evaluated in accordance with the following:

ASTM E 1886-05 / ASTM E 1996-06
Missile Level "D" (Includes Wind Zone 4)

Test Specimen Description:

Series / Model:	Westwood 250 Casement Windows
Type:	Aluminum Casement Windows
Overall Size:	42.00" x 84.00 – Specimen 6a – (X) 42.00" x 72.00" – Specimen 12a – (X)
Daylight Opening:	33.063" x 75.13" – Specimen 6a – (X) 32.88" x 56.06" – Specimen 12a – (X)
Glazing Detail:	See attached drawings for glazing details.
Frame Material:	Aluminum
Finish:	Mill Finish

For Tested Elevation, Vertical Cross Sections, Horizontal Cross Sections, Components, Frame Anchoring, Glazing Detail and Bill of Materials See Attached Drawing number L-7167.

IMPACT AND CYCLING TESTS

Specimen 6A – 42.0" x 84.0" Aluminum Casement Window –Direct Mount – (X)

ASTM E1886-05/ASTM E1996-06 – Large Missile Impact (2 x 4 Southern Yellow Pine)

Cond. Temp Of Specimen	Missile Level	Missile Weight	Missile Length	Muzzle Distance From Specimen
76°F	D	9.0 lbs, 2 oz	8'-1/4"	17'1"

Impact Location	Results	X - Measurement	Y - Measurement	Speed
1	Pass	20.75"	42.00"	49.9 fps
2	Pass	11.25"	74.75"	50.0 fps
Orientation of Missile at Impact was within +/-5° of horizontal. None of the impacts penetrated the specimens. "X" measurement is from the left edge of test specimen. "Y" measurement is from the bottom edge of test specimen.				

ASTM E1886-05/ASTM E1996-06– Fatigue Load Cycling Design Pressure +65.0 psf / -65.0 psf

Positive % of Test Load	Positive Pressure Range (psf)	Number Of Cycles	Average Cycle Time (Sec)
20% to 50%	13.0 to 32.5	3500	2.41
0% to 60%	0.0 to 39.0	300	2.79
50% to 80%	32.5 to 52.0	600	2.05
30% to 100%*	19.5 to 65.0	100	2.26

Negative % of Test Load	Negative Pressure Range (psf)	Number Of Cycles	Average Cycle Time (Sec)
30% to 100%*	19.5 to 65.0	50	2.95
50% to 80%	32.5 to 52.0	1050	1.55
0% to 60%	0.0 to 39.0	50	2.09
20% to 50%	13.0 to 32.5	3350	1.68

*Panel deflected 2.50" from original plane at 100% Positive load and 2.88" from original plane at 100% Negative load. At the completion of cycles the door panel was operable. There were no tears in the film. In our opinion, the tape and film used to seal for air leakage did not influence the results of the test.

Jarrett Wright and James Hayhurst, Test Technicians

Mfg Observers – Joe Zammit

IMPACT AND CYCLING TESTS

Specimen 12A – 42.0" x 72.0" Aluminum Casement Window – (X)

ASTM E1886-05/ASTM E1996-06 – Large Missile Impact (2 x 4 Southern Yellow Pine)

Cond. Temp Of Specimen	Missile Level	Missile Weight	Missile Length	Muzzle Distance From Specimen
76°F	D	9.0 lbs, 2 oz	8'-1/4"	17'1"

Impact Location	Results	X - Measurement	Y - Measurement	Speed
1	Pass	21.00"	36.00"	49.8 fps
2	Pass	9.00"	9.50"	50.1 fps
Orientation of Missile at Impact was within +/-5° of horizontal. None of the impacts penetrated the specimens. "X" measurement is from the left edge of test specimen. "Y" measurement is from the bottom edge of test specimen.				

ASTM E1886-05/ASTM E1996-06– Fatigue Load Cycling Design Pressure +65.0 psf / -65.0 psf

Positive % of Test Load	Positive Pressure Range (psf)	Number Of Cycles	Average Cycle Time (Sec)
20% to 50%	13.0 to 32.5	3500	2.12
0% to 60%	0.0 to 39.0	300	1.71
50% to 80%	32.5 to 52.0	600	1.65
30% to 100%*	19.5 to 65.0	100	2.26

Negative % of Test Load	Negative Pressure Range (psf)	Number Of Cycles	Average Cycle Time (Sec)
30% to 100%*	19.5 to 65.0	50	2.17
50% to 80%	32.5 to 52.0	1050	1.37
0% to 60%	0.0 to 39.0	50	1.93
20% to 50%	13.0 to 32.5	3350	2.69

*Panel deflected 1.75" from original plane at 100% Positive load and 1.75" from original plane at 100% Negative load. At the completion of cycles the door panel was operable. There were no tears in the film. In our opinion, the tape and film used to seal for air leakage did not influence the results of the test.

Jarrett Wright and James Hayhurst, Test Technicians

Mfg Observers – Joe Zammit

Conditions, Terms, and General Notes Regarding These Tests

The product tested Has Been compared to the detailed drawing, bill of materials and fabrication information supplied by the client so named herein. Our analysis, which includes dimensional and component description comparisons, indicate the tested product and engineering information supplied by the client "Are Equivalent". The report and representative samples will be retained for four years from the date of initial test.

These test results were obtained by employing all requirements of the designated test methods with no Deviations unless explicitly noted in test report. The test results and specimen supplied for testing are in compliance with the reference.

The test results are specific to the product tested by this laboratory and of the sample supplied by the client named herein, and they relate to no other product either manufactured by the client, a fabricator of the client or of the client or of installed field performance.

This test report does not constitute certification of this product, but only that the above test results were obtained using the designated test methods and they indicate compliance with the performance requirements (paragraphs as listed) of the above referenced specifications.

Testing Evaluation Laboratories, Inc. makes no opinions or endorsements regarding this product and its performance. This report may not be reproduced or quoted in partial form without the expressed written approval of Testing Evaluation Laboratories, Inc.

Testing Evaluation Laboratories, Inc.'s letter, reports, its name or insignia or mark are for the exclusive use of the client so named herein and any other use is strictly prohibited. The report, letters and the name of Testing Evaluation Laboratories, Inc., its seal or mark shall not be used in any circumstance to the general public or in any advertising.

Limitation of liability: Due diligence was used in performing the tests and reporting the results. By acceptance of this report, this client agrees to hold harmless and indemnify Testing Evaluation Laboratories, Inc., its employees, sub-contractors, officers and owners against all claims and demands of any kind whatsoever, which arise out of or in any manner connected with the performance of work referred to herein.

Testing Evaluation Laboratories, Inc.



Vivian K. Wright,
President

Revision Log

Rev No.	Date	Page(s)	Revision(s)
0	6/14/2014	NA	Original Report Issue

TABLE OF CONTENTS	
SHEET #	DESCRIPTION
1	Table of contents
2	Test elevation
3	Horizontal and vertical cross sections
4	Horizontal and vertical cross sections
5	Frame anchoring
6	Frame anchoring
7	Components
8	Glazing details
9	Bill of materials

Testing Evaluation Laboratories Inc
 Specimen Complies with Drawing
 Deviations Noted - TEL # 01991057
 Date 6-14-14 Verified by gwo



DATE: 6/14/14
 SCALE: N.T.S.
 DWG. BY: JK
 CHK. BY: LFS
 DRAWING NO.:
 L-7167
 SHEET 1 OF 9

PRODUCT: FLEETWOOD Westwood 250 CASEMENT WINDOW	
PART OR ASSEMBLY: TABLE OF CONTENTS	
NO.	DATE
BY	REVISIONS

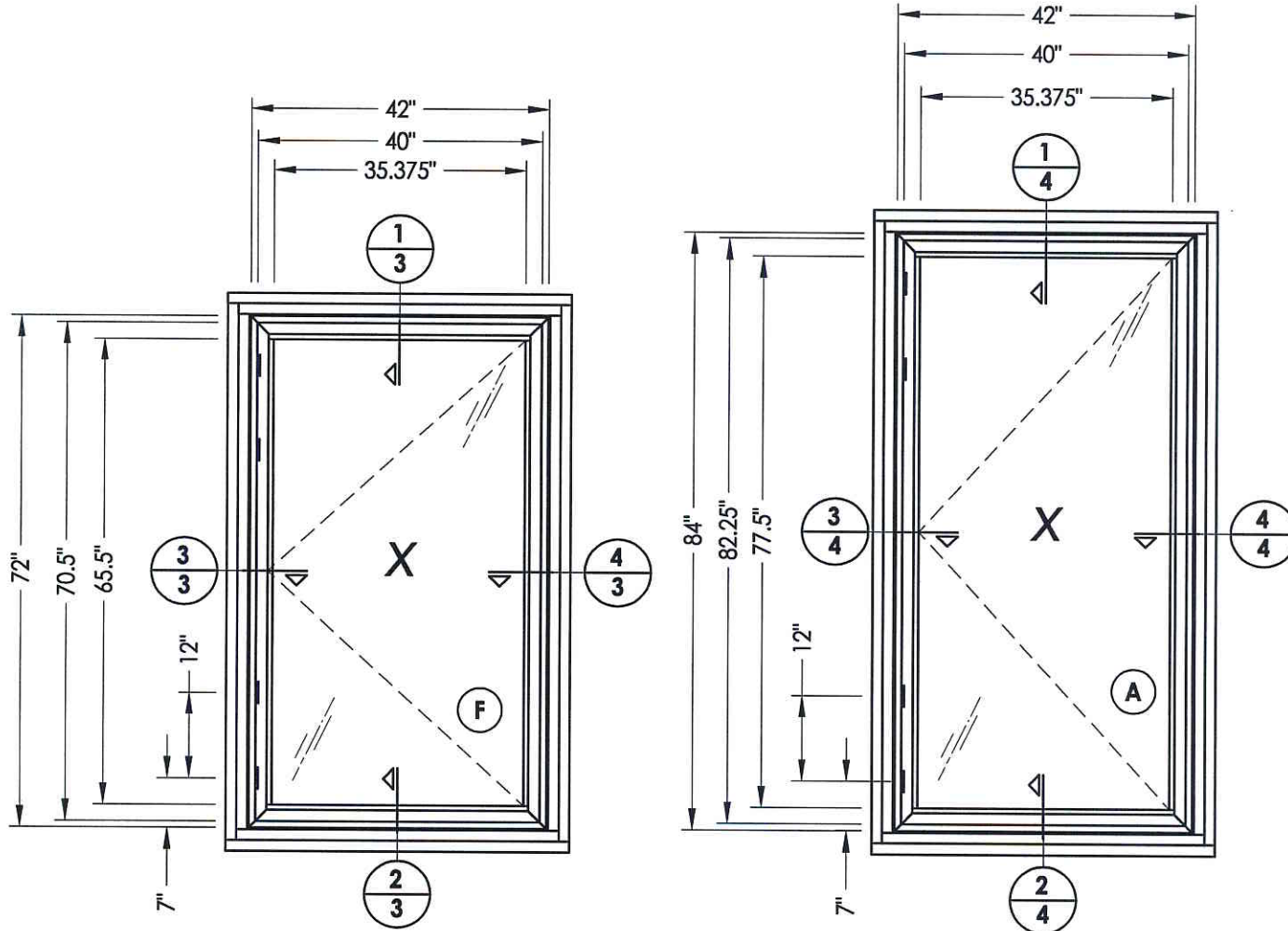

SPEC# 12, 12A

SPEC# 6, 6A

Testing Evaluation Laboratories inc
 Specimen Complies with Drawing
 Deviations Noted - TEL # 01991057
 Date 6-14-14 Verified by JW

PRODUCT: FLEETWOOD Westwood 250 CASEMENT WINDOW		PART OR ASSEMBLY: TEST ELEVATION	
NO.	DATE	REVISIONS	BY
RW BUILDING CONSULTANTS, INC. 813.659.9197			
DATE: 6/14/14			
SCALE: N.T.S.			
DWG. BY: JK			
CHK. BY: LFS			
DRAWING NO.: L-7167			
SHEET 2 OF 9			

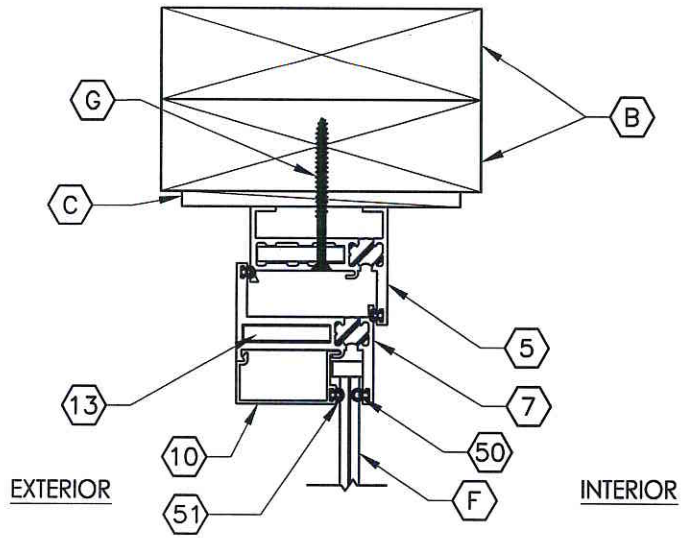

1
3 VERTICAL CROSS SECTION

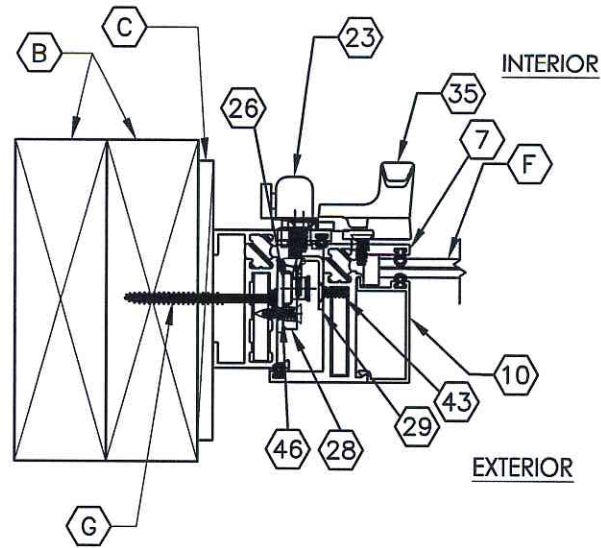

3
3 HORIZONTAL CROSS SECTION

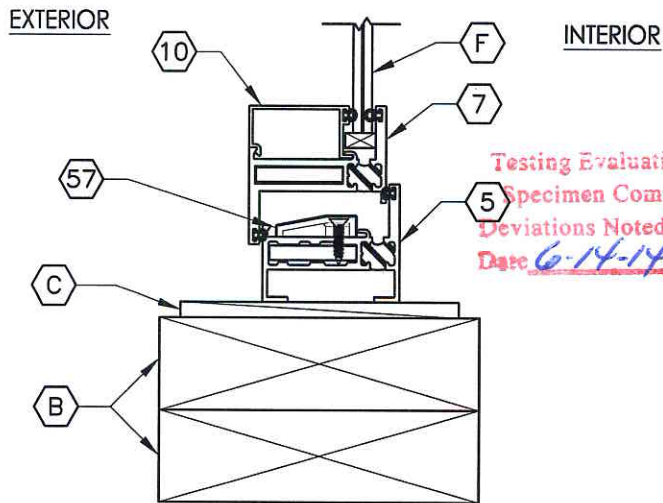

2
3 VERTICAL CROSS SECTION

Testing Evaluation Laboratories Inc
 Specimen Complies with Drawing
 Deviations Noted - TEL # 01991057
 Date 6-14-14 Verified by gaw

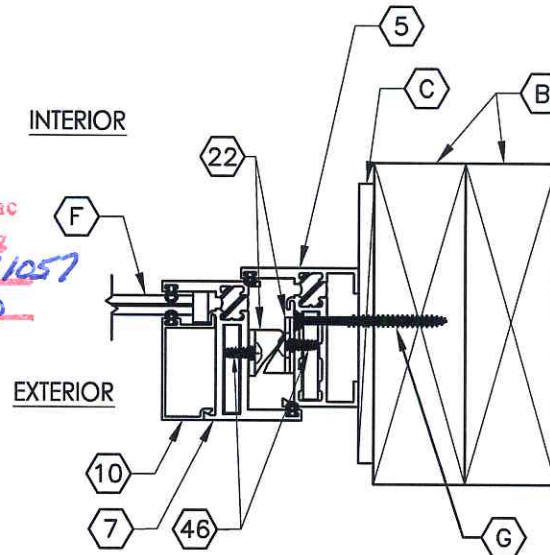

4
3 HORIZONTAL CROSS SECTION

PRODUCT:		FLEETWOOD Westwood 250 CASEMENT WINDOW	
PART OR ASSEMBLY:		HORIZONTAL AND VERTICAL CROSS SECTIONS	
NO.	DATE	BY	REVISIONS
DATE: 6/14/14			
SCALE: N.T.S.			
DWG. BY: JK			
CHK. BY: LFS			
DRAWING NO.: L-7167			
SHEET <u>3</u> OF <u>9</u>			

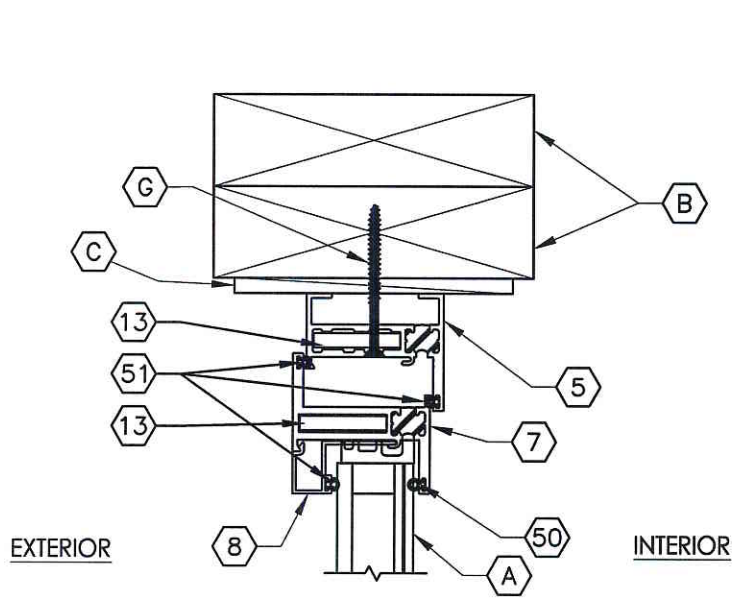

1
4 **VERTICAL CROSS SECTION**

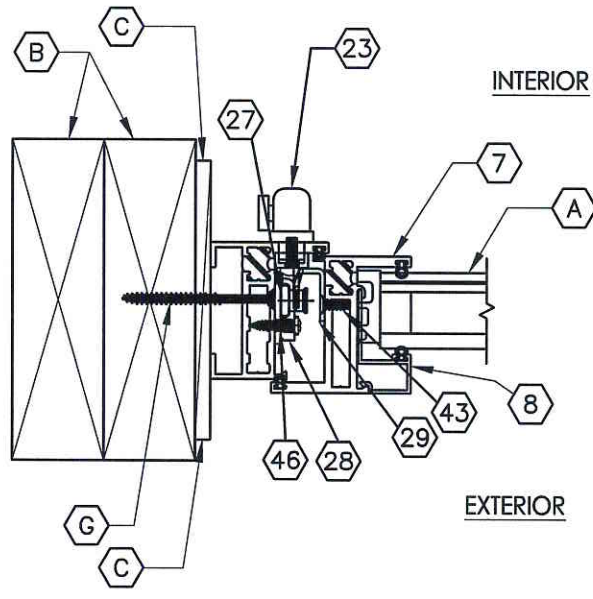

3
4 **HORIZONTAL CROSS SECTION**

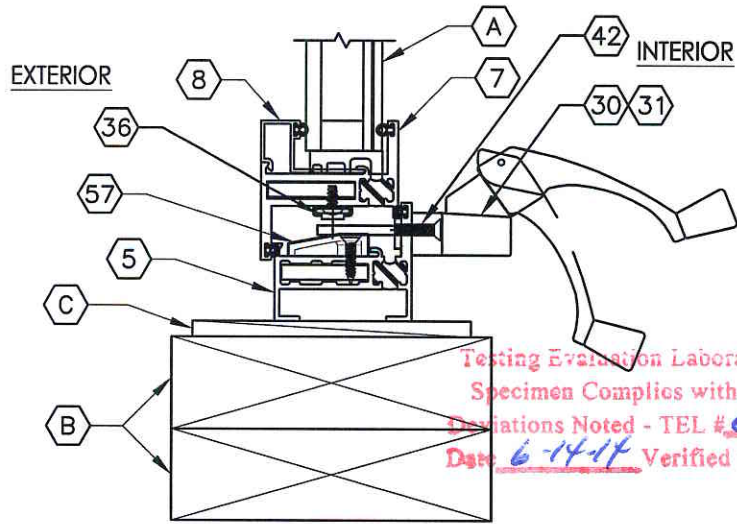

2
4 **VERTICAL CROSS SECTION**

Testing Evaluation Laboratories Inc
Specimen Complies with Drawing
Deviation Noted - TEL # 01991057
Date 6-14-14 Verified by *ju*

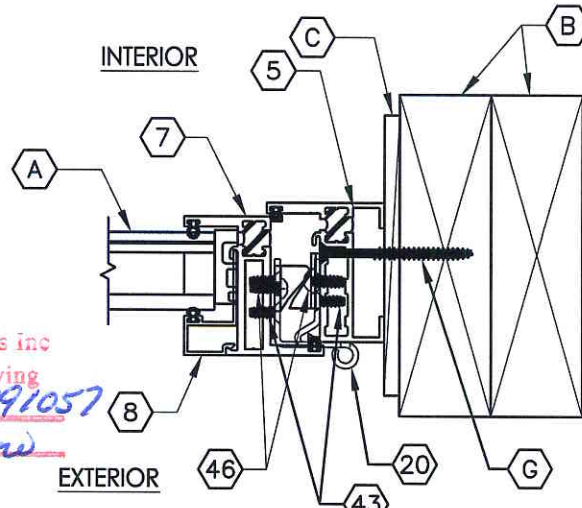

4
4 **HORIZONTAL CROSS SECTION**

PRODUCT:		FLEETWOOD Westwood 250 CASEMENT WINDOW	
PART OR ASSEMBLY:		HORIZONTAL AND VERTICAL CROSS SECTIONS	
NO.	DATE	BY	REVISIONS
DATE: 6/14/14			
SCALE: N.T.S.			
DWG. BY: JK			
CHK. BY: LFS			
DRAWING NO.: L-7167			
SHEET 4 OF 9			

Testing Evaluation Laboratories Inc
 Specimen Complies with Drawing
 Deviations Noted - TEL # 01991057
 Date 6-14-14 Verified by gw

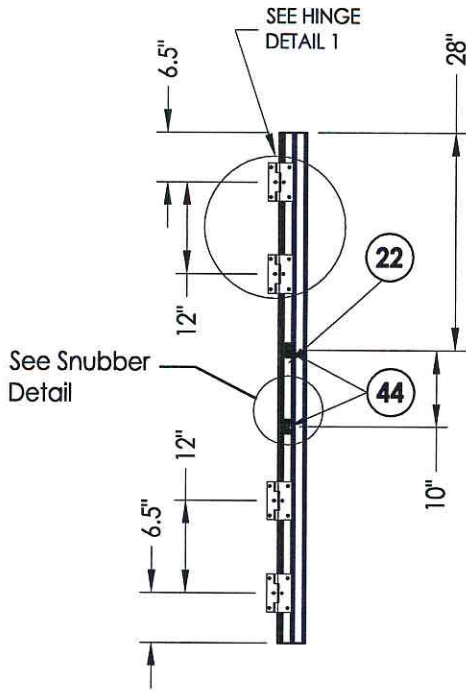

SNUBBER JAMB

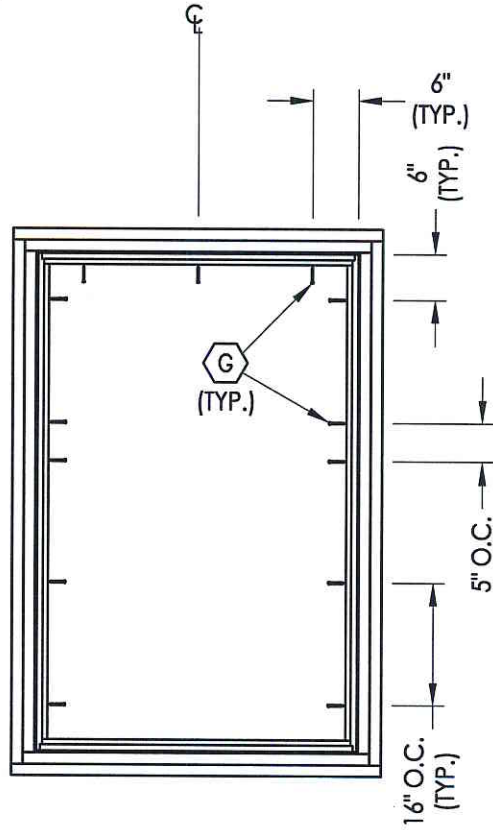

FRAME ANCHORING
 2X buck construction

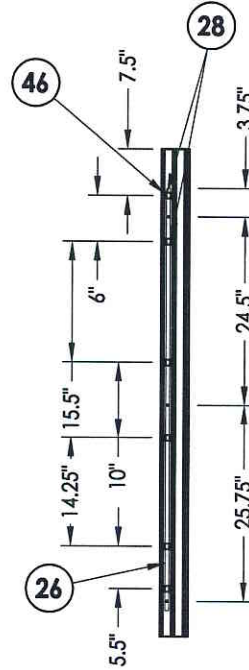

LOCK JAMB
 Locking Points (3)

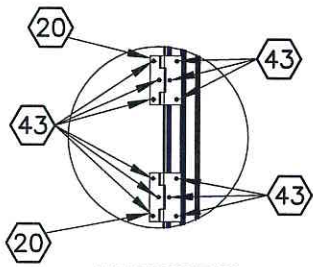

HINGE DETAIL

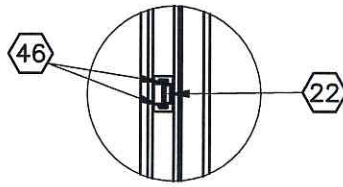

SNUBBER DETAIL

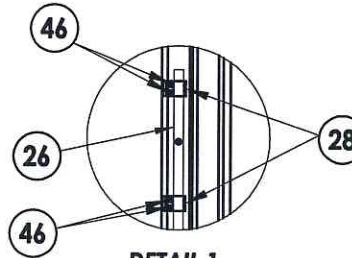

DETAIL 1

PRODUCT: FLEETWOOD Westwood 250 CASEMENT WINDOW		PART OR ASSEMBLY: FRAME ANCHORING	
NO.	DATE	REVISIONS	BY
 RW BUILDING CONSULTANTS, INC. 813.659.9197			
DATE: 6/14/14			
SCALE: N.T.S.			
DWG. BY: JK			
CHK. BY: LFS			
DRAWING NO.: L-7167			
SHEET 5 OF 9			

Testing Evaluation Laboratories Inc
 Specimen Complies with Drawing
 Deviations Noted - TEL # 01991057
 Date 6-14-14 Verified by *gjo*

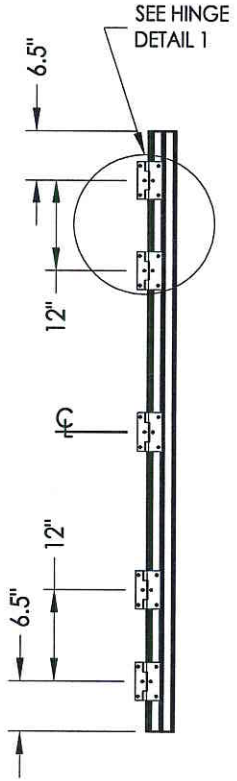

HINGE JAMB

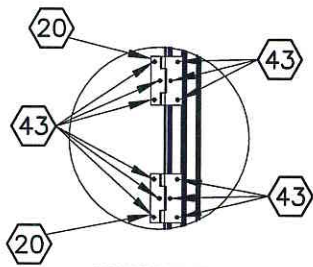

HINGE DETAIL

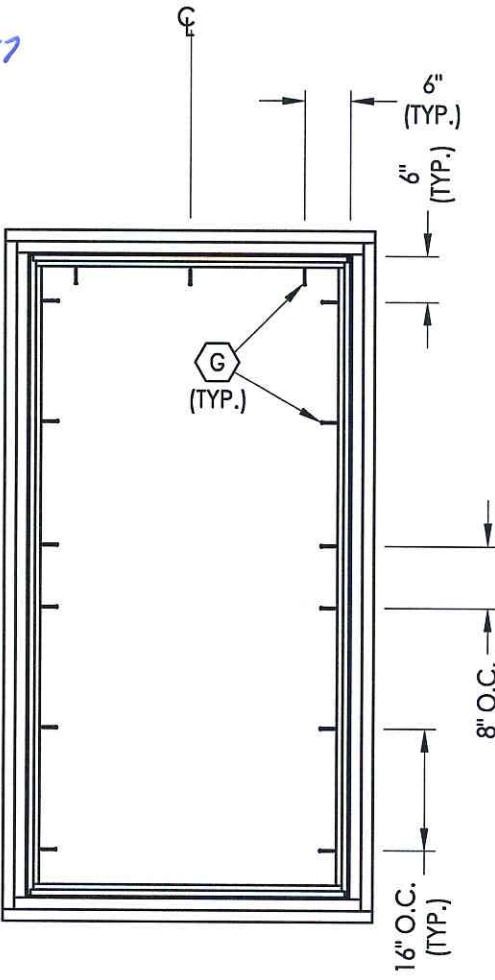

FRAME ANCHORING
2X buck construction

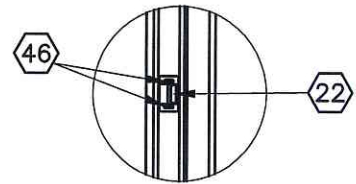

SNUBBER DETAIL

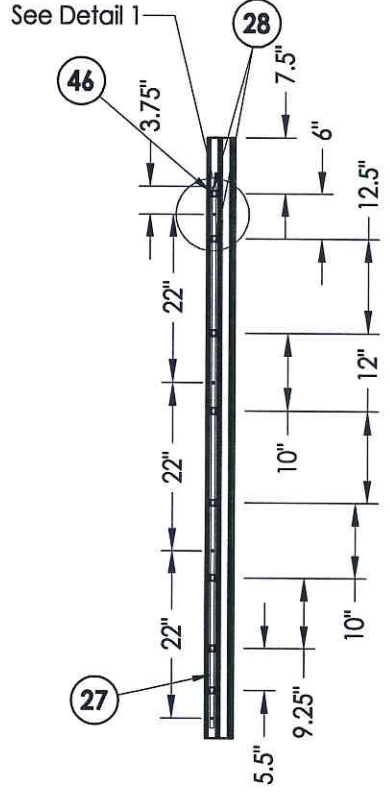

LOCK JAMB
Locking Points (4)

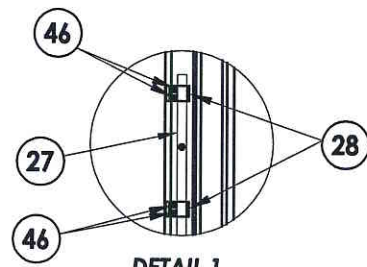

DETAIL 1

PRODUCT: FLEETWOOD Westwood 250 CASEMENT WINDOW	
PART OR ASSEMBLY: FRAME ANCHORING	
NO.	REVISIONS
DATE	BY
DATE: 6/14/14	
SCALE: N.T.S.	
DWG. BY: JK	
CHK. BY: LFS	
DRAWING NO.: L-7167	
SHEET 6 OF 9	

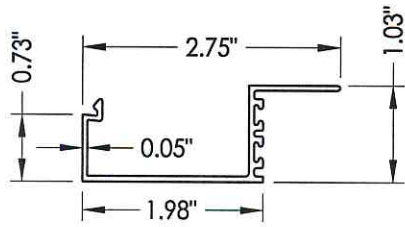

14 **INSERT STOP**
011448

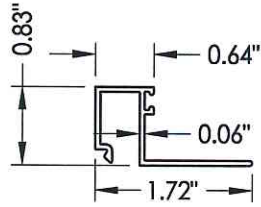

8 **GLASS STOP 1-1/4"**
901487

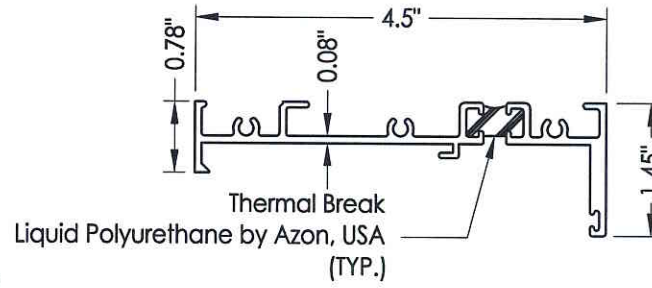

2 **KONA BLOCK FRAME**
011239

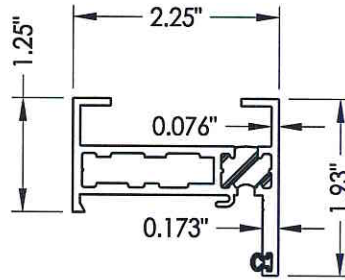

5 **BLOCK FRAME**
5278C1

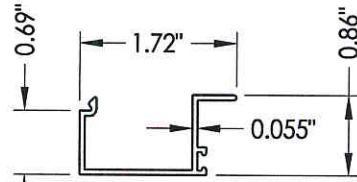

10 **GLASS STOP 5/16", 7/16"**
007930

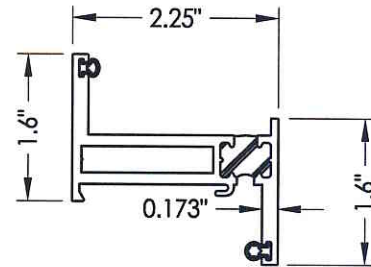

7 **ZEE BAR (PANEL)**
H006733

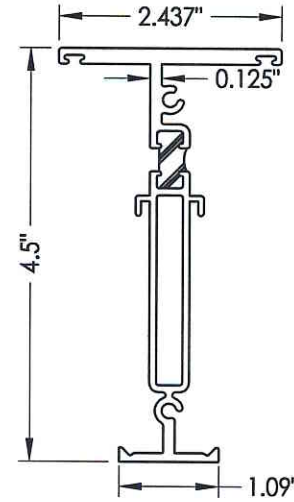

4 **MULLION**
H011241

Testing Evaluation Laboratories Inc
Specimen Complies with Drawing
Deviations Noted - TEL # 01991057
Date 6-14-14 Verified by gju

PRODUCT:		FLEETWOOD Westwood 250 CASEMENT WINDOW	
PART OR ASSEMBLY:		COMPONENTS	
NO.	DATE	BY	REVISIONS
DATE: 6/14/14			
SCALE: N.T.S.			
DWG. BY: JK			
CHK. BY: LFS			
DRAWING NO.: L-7167			
SHEET <u>7</u> OF <u>9</u>			

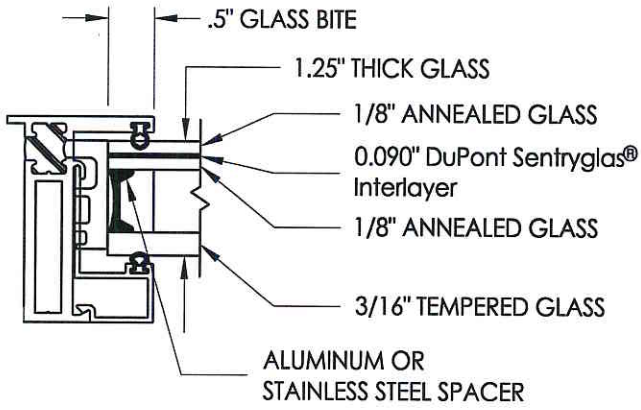

A GLAZING DETAIL

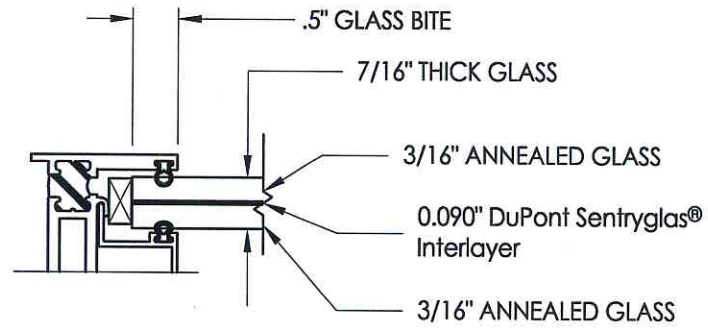

F GLAZING DETAIL

Testing Evaluation Laboratories Inc
 Specimen Complies with Drawing
 Deviations Noted - TEL # 01991057
 Date 6-14-14 Verified by gw

PRODUCT:		FLEETWOOD Westwood 250 CASEMENT WINDOW	
PART OR ASSEMBLY:		COMPONENTS AND GLAZING DETAILS	
NO.	DATE	REVISIONS	BY
 RW BUILDING CONSULTANTS, INC. 813.659.9197			
DATE: 6/14/14			
SCALE: N.T.S.			
DWG. BY: JK			
CHK. BY: LFS			
DRAWING NO.: L-7167			
SHEET 8 OF 9			

BILL OF MATERIALS

ITEM #	DESCRIPTION	MATERIAL
B	2X BUCK SG >= 0.55	WOOD
C	1/4" MAX. SHIM SPACE	-
G	#10 x 2" PFH WOOD SCREW	STEEL
2	KONA BLOCK FRAME	6063-T6 ALUM
4	MULLION	6063-T6 ALUM
5	WESTWOOD BLOCK FRAME	6063-T6 ALUM
7	WESTWOOD ZEE BAR (PANEL)	6063-T6 ALUM
8	GLASS STOP (1-1/4")	6063-T6 ALUM
10	GLASS STOP (7/16")	6063-T6 ALUM
13	CORNER KEY	ALUM
14	INSERT STOP	ALUM
20	SS. BUTT HINGE	SS
21	4 BAR HINGE	SS
22	SNUBBER	ZINC ALLOY
23	MULTIPOINT LOCK HANDLE	SS
26	3 POINTS LOCKING BAR	SS
27	4 POINTS LOCKING BAR	SS
28	TIE BAR GUIDE	PLASTIC
29	KEEPER	SS
30	CASEMENT ROTOR GEAR 13.5"	SS
35	CAM HANDLE / STRIKE PLATE	SS
36	CASEMENT SS. TRACK	SS
40	#10 X 1" PPH SMS	STEEL
42	MACHINE SCREW NO 10-32, FHP .75"	STEEL
43	SCREW NO 10 , UFHP .5"	STEEL
44	SCREW NO 8, PHP, .50"	STEEL
46	SCREW NO 8, FHP, .750"	STEEL
47	MACHINE SCREW NO 10-32, PHP .5"	STEEL
48	BACK UP NUTS	STEEL
50	BULB VINYL (EPDM 70 DUROMETER)-TREMCO	-

51	MINI BULB VINYL(EPDM 70 DUROMETER)-TREMCO	-
52	WOOD BLOCK .750" X 1.250"	-
53	ALUMINUM BLOCK .750" X 1.250"	-
54	PVC BLOCK .750" X 1.250"	-
55	SETTING BLOCK	-
56	SETTING BLOCK 4" x 1/4" x 1"	-
57	PIVOT SHIM	-
58	WOOD BLOCK .50" X 1.250"	-
59	ALUMINUM BLOCK .50" X 1.250"	-
60	PVC BLOCK .50" X 1.250"	-
61	SETTING BLOCK 4" x 1/8" x 1"	-

PRODUCT: FLEETWOOD Westwood 250 CASEMENT WINDOW	PART OR ASSEMBLY: BILL OF MATERIALS	
		REVISIONS NO. DATE BY
		
DATE: 6/14/14		
SCALE: N.T.S.		
DWG. BY: JK		
CHK. BY: LFS		
DRAWING NO.: L-7167		
SHEET 9 OF 9		

Testing Evaluation Laboratories inc
 Specimen Complies with Drawing
 Deviations Noted - TEL # 01991057
 Date 6-14-14 Verified by JW

FITS WITH PARTS

FLE 27177, FLE 27179, & FLE 27180

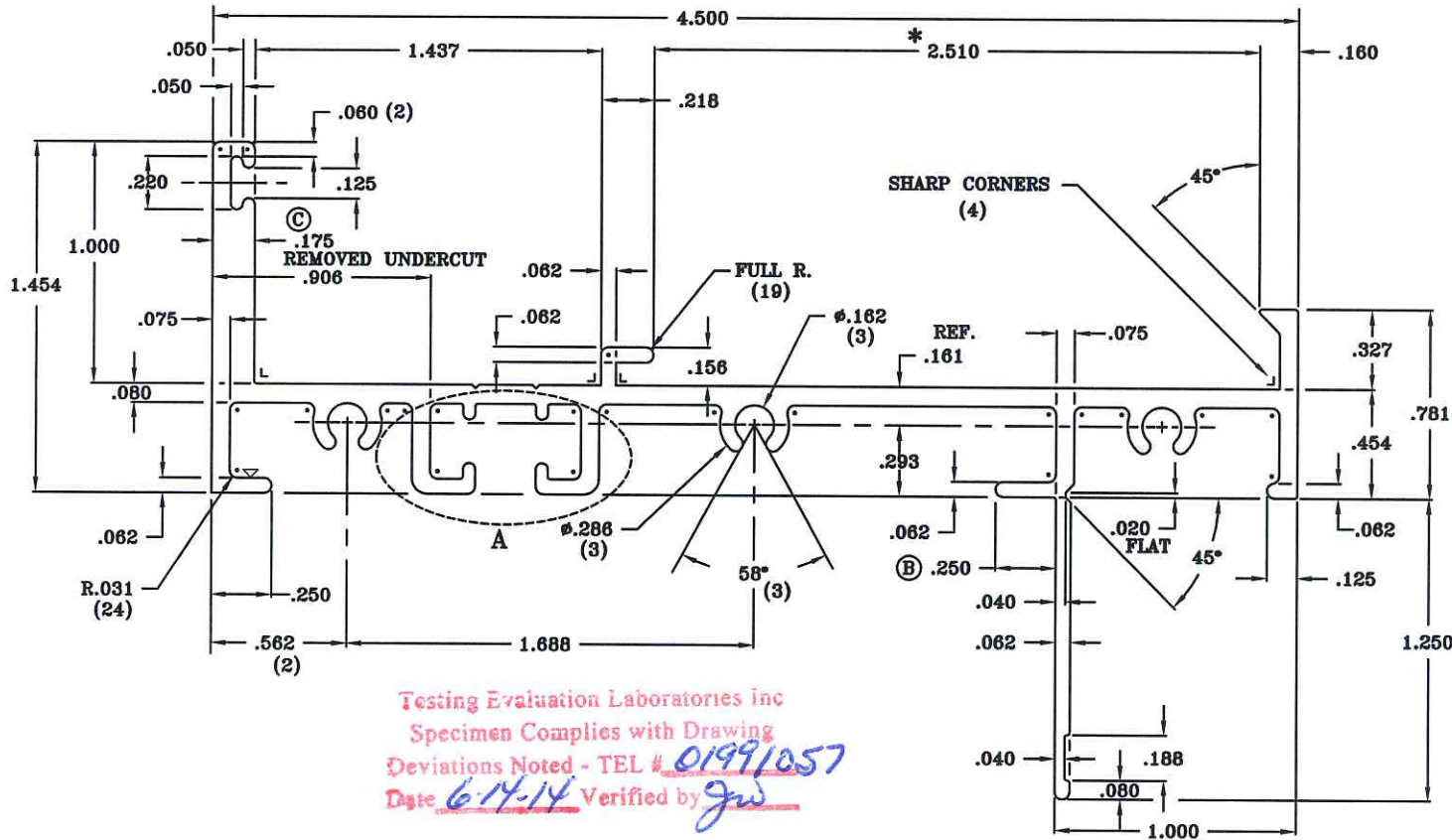

Testing Evaluation Laboratories Inc
 Specimen Complies with Drawing
 Deviations Noted - TEL # 01991057
 Date 6-14-14 Verified by *gw*

THRMAL FILL AREA = .193 SQ. IN.

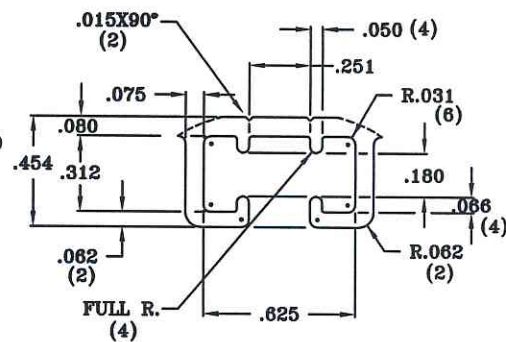

DETAIL "A"
SCALE: 4:1

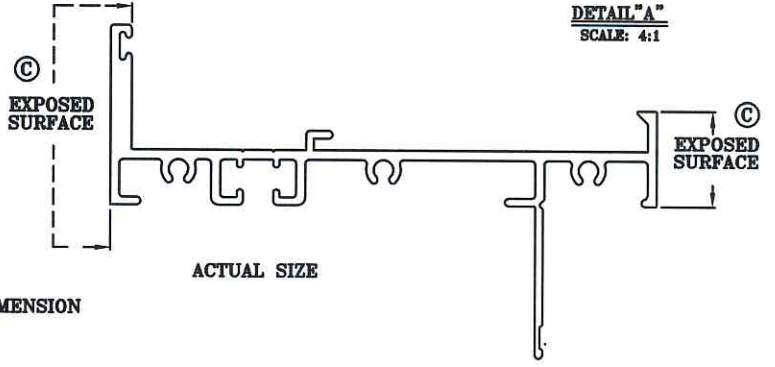

* CRITICAL DIMENSION

D.010 R. X .010DEEPI.D. MARK NOTE: .075 TYP. WALL EXCEPT AS NOTED UNMARKED CORNERS .010 R.

CONTAINER	7/8	DIE RING	5	SPACER RING	2				
AREA	.921	PORTS	1	BER	11238				
WT/FT	1.105	W/P	POCKET	BOLSTER	11238	C	ADDED MISSING DIM. TO PART NAME	ED 11/12/03	
FEEL	22.854	FLE	27176	DIE SIZE	9X2	C	REMOVED UNDERCUT WT/FT. WAS 1.087, P. 23.007	ED 11/12/03	
DWN. BY	KEN	DATE	11/12/03	MAT'L	6063-T6	B	ADDED MISSING DIM.	ED 7/23/01	
CHEK. BY		DATE		STANDARD TOLERANCES UNLESS OTHERWISE NOTED		INT.	REVISION	BY DATE	
				CUSTOMER	FLEETWOOD ALUMINUM	SCALE	2:1	PART NO.	3805
SIERRA ALUMINUM COMPANY 2345 Fleetwood Drive Riverside, California 92509 (909)781-7800 FAX (909)781-7864				PART NAME	4.500 FRAME BLOCK		930 N/C	DIE NO.	011239

FITS WITH PARTS

FLE 27177, FLE 27179, & FLE 27180

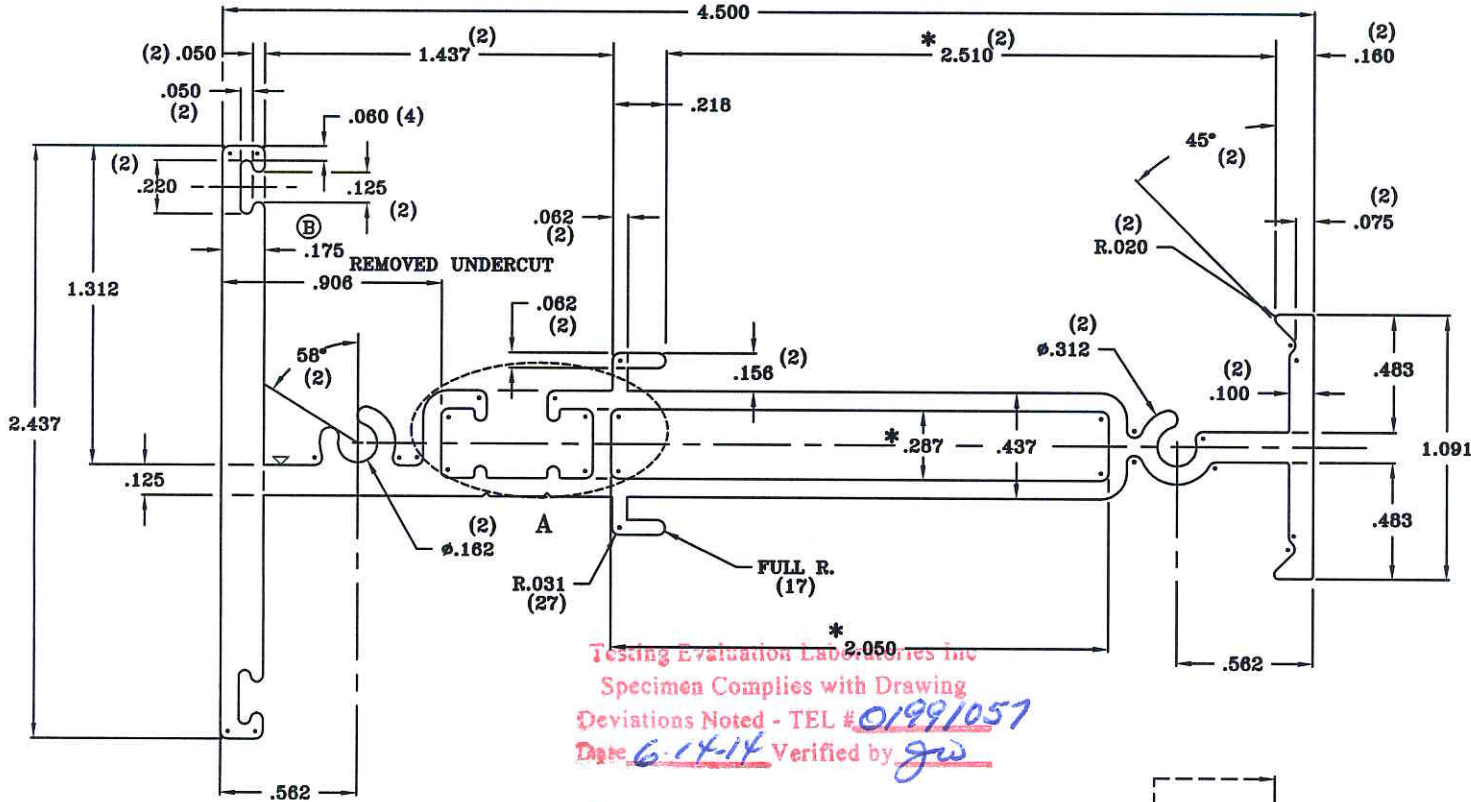

Testing Evaluation Lab, Inc.
 Specimen Complies with Drawing
 Deviations Noted - TEL # 01991057
 Date 6-14-14 Verified by jw

* CRITICAL DIMENSION

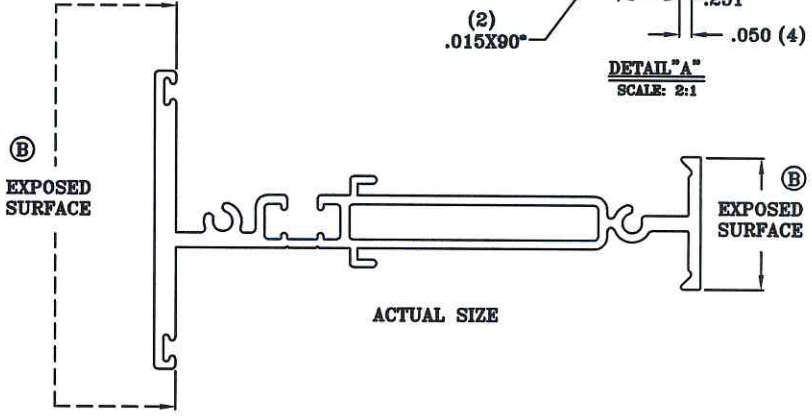
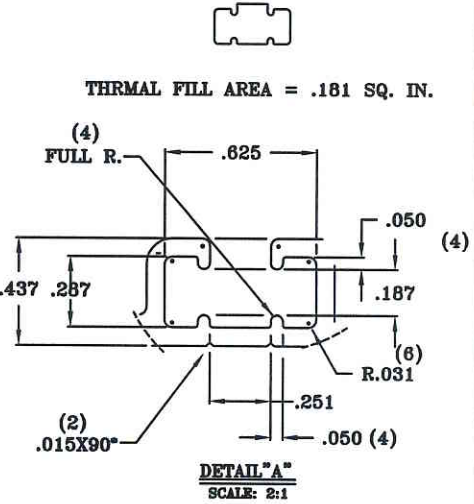

▷.010 R. X .010DEEPLD. MARK

NOTE: .075 TYP. WALL EXCEPT AS NOTED UNMARKED CORNERS .010 R.

CONTAINER	8	DIE RING	5	SPACER RING	2				
AREA	1.232	PORTS	1	DIE	-				
WT/FT	1.478	W/P	-	BOLSTER	11238				
FEEL	25.766	FLE 27178		DIE SIZE	9X5	B	ARMED EXPOSED SURFACE	ED	11/18/08
DWN. BY	KEN	DATE	11/12/03	MAT'L	6063-T6	B	REMOVED UNDERCUT	ED	11/18/08
CHKD. BY		DATE		STANDARD TOLERANCES UNLESS OTHERWISE NOTED		LET.	REVISION	BY	DATE
SIERRA ALUMINUM COMPANY 2345 Fleetwood Drive Riverside, California 92509 (909)781-7800 FAX (909)781-7864				CUSTOMER FLEETWOOD ALUMINUM		SCALE 2:1	PART NO. 3806		
				PART NAME MULLION		1900 N/C	DIE NO. H-011241		

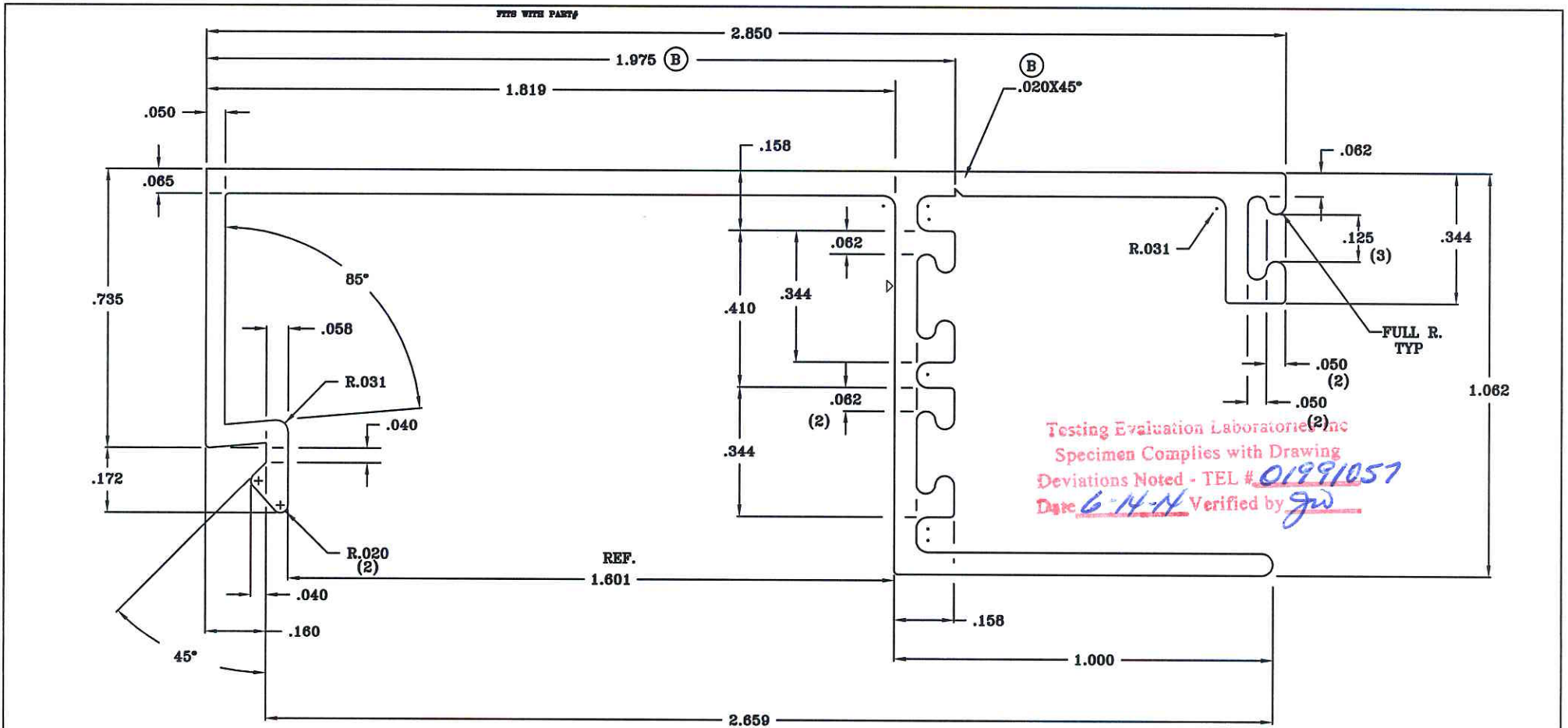

▷.010 R. X .010DEEPL.D. MARK NOTE: .058 TYP. WALL EXCEPT AS NOTED
UNMARKED CORNERS .010 R.

CONTAINER	8	DIE RING	5	SPACER RING	2				
AREA	.415	PORTS	3	DIE	011448				
WT./FT	.498	V/P	POCKET	BOLSTER	3-6				
PERL.	13.489	FLE	28807	DIE SIZE	9X2				
DWN. BY	KEN	DATE	4/24/02	MATL.	6063-T6	B	RELOCATE .080X45°	ED	9/29/08
CHD. BY		DATE		STANDARD TOLERANCES UNLESS OTHERWISE NOTED		LET.	REVISION	BY	DATE
				CUSTOMER		SCALE		PART NO.	
SIERRA ALUMINUM COMPANY				FLEETWOOD ALUMINUM		4:1		3811	
2345 Fleetwood Drive Riverside, California 92509 (909)781-7800 FAX (909)781-7884				PART NAME		N/C		DIE NO.	
				GLASS STOP				011448	

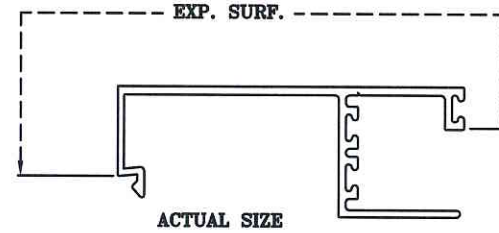

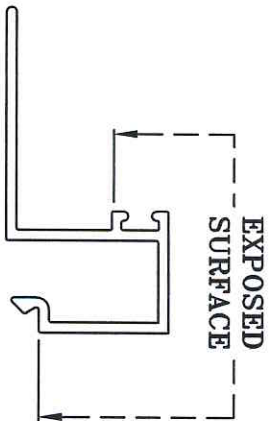

ACTUAL SIZE

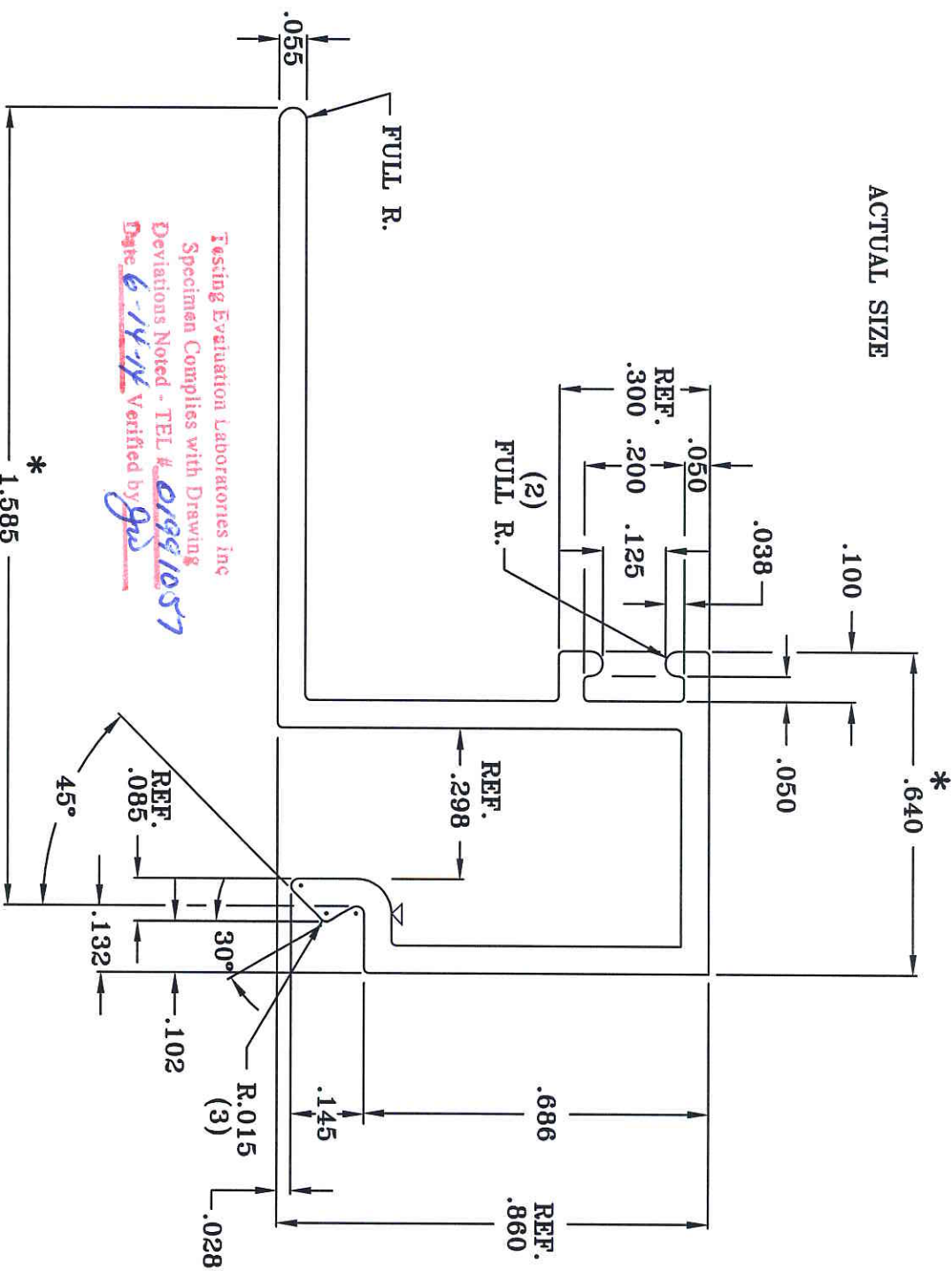

Testing Evaluation Laboratories Inc
 Specimen Complies with Drawing
 Deviations Noted - TEL # .01921057
 Date 6-14-14 Verified by *gms*

* CRITICAL DIMENSION

▷.010 R. X .010DEEPI.D. MARK

NOTE: .055 TYP. MAIL EXCEPT AS NOTED
 UNMARKED CORNERS .010 R.

CONTAINER	7	DIE RING	5	SPACER RING	2		
AREA	.202	PARTS	4	BR	901487		
WT/PT	.242	W/P	POCKET	BOLSTER	STD-4		
PERL.	7.360	FLEE33161		DIE SIZE	9X2		
DWN. BY	KEN	DATE	3/12/04	MAT'L.	6063-T6		
CHKD. BY		DATE		STANDARD TOLERANCES UNLESS OTHERWISE NOTED		LET.	



SIERRA ALUMINUM COMPANY
 2345 Fleetwood Drive
 Riverside, California 92509
 (909)781-7800 FAX (909)781-7864

CUSTOMER
FLEETWOOD WINDOWS & DOORS

PART NAME
GLASS STOP, 1-1/4"

SCALE 2:1	PART NO. 05P12
N/C	DIE NO. 901487

FITS WITH PART#

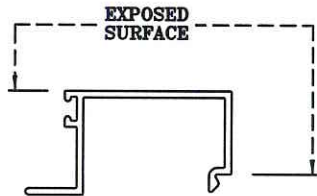
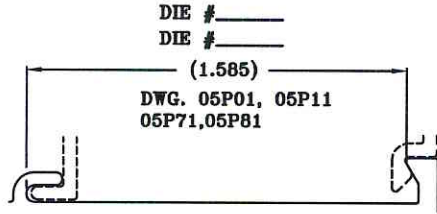

ACTUAL SIZE

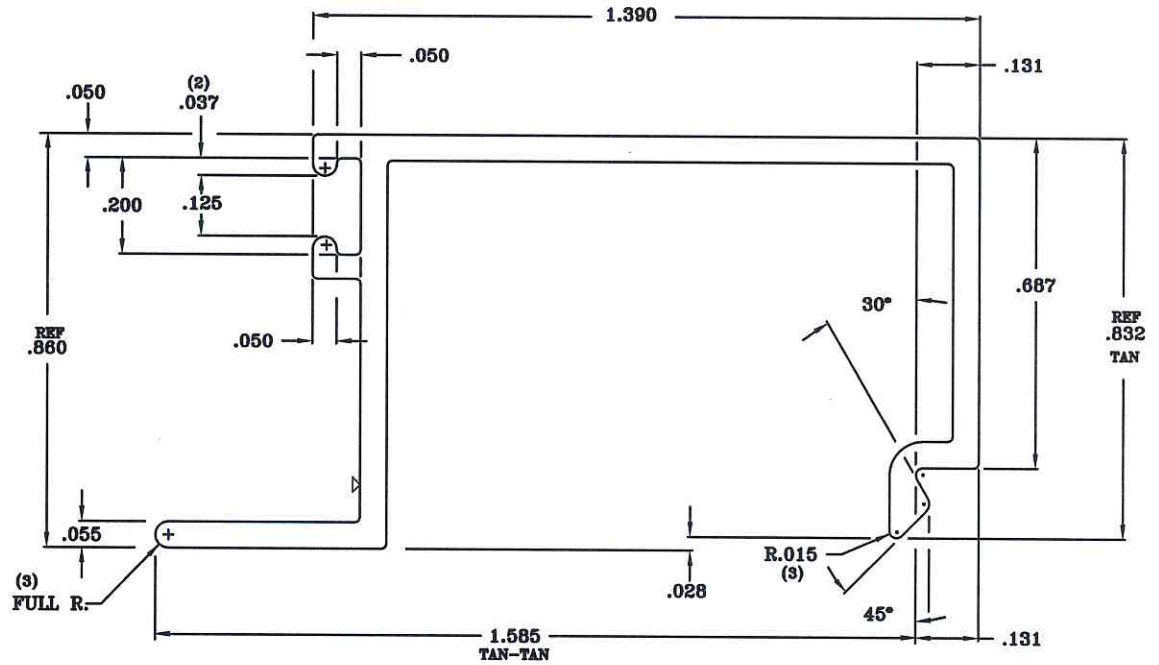

▷.010 R. X .010HIGH I.D. MARK NOTE: .055 TYP. WALL EXCEPT AS NOTED
 UNMARKED CORNERS .010 R.

CONTAINER	7	DIE RING	4	SPACER RING	3				
AREA	.202	PORTS	4	EEK	2372				
WT/PT	.242	W/P	-	BOLSTER	4-9				
PHIL.	7.337	FLE9686		DIE SIZE	9x1				
DWN. BY	HILDA	DATE	6/03/94	MAT'L.	6063-T6				
CHD. BY		DATE		STANDARD TOLERANCES UNLESS OTHERWISE NOTED	LET.	REVISION	BY	DATE	
SIERRA ALUMINUM COMPANY 2345 Fleetwood Drive Riverside, California 92509 (909)781-7800 FAX (909)781-7884				CUSTOMER FLEETWOOD ALUMINUM PRODUCTS PART NAME GLASS STOP 1/2" ...5000		SCALE 4:1	PART NO. 05P08	DIE NO. 007930	

Testing Evaluation Laboratories Inc
 Specimen Complies with Drawing
 Deviations Noted - TEL # 01991057
 Date 6-14-14 Verified by JWD

FITS WITH PART 9

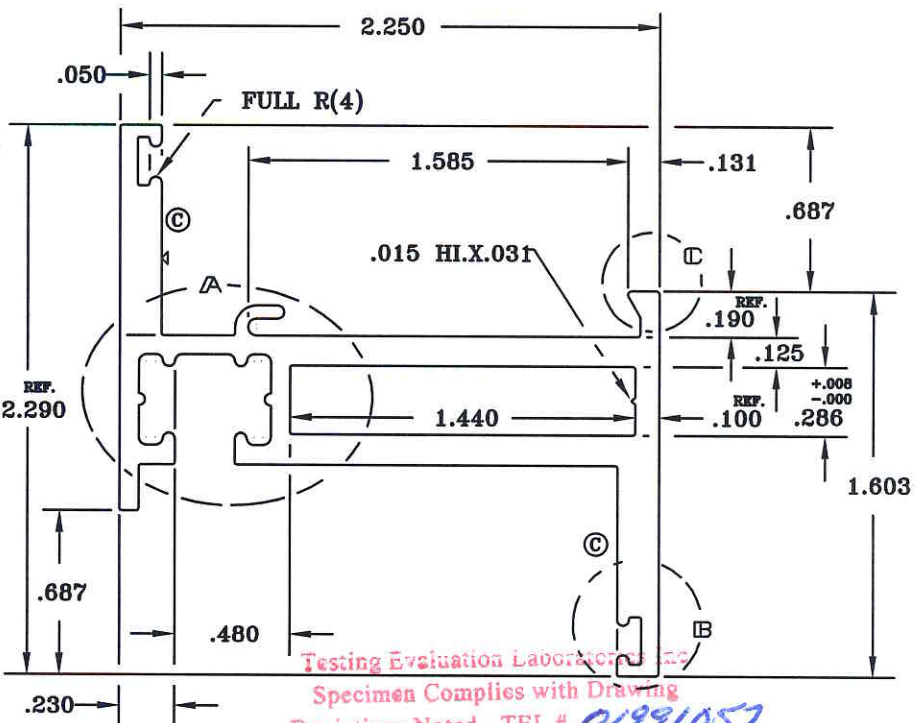
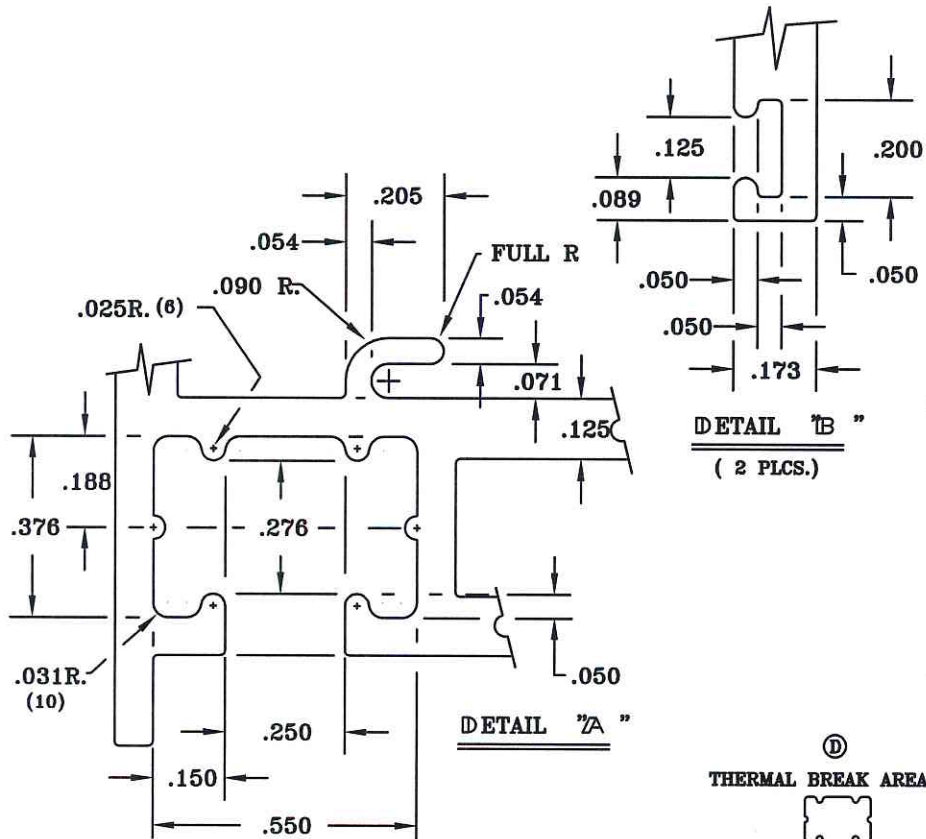

Testing Evaluation Laboratories Inc
 Specimen Complies with Drawing
 Deviations Noted - TEL # 01991057
 Date 6-14-14 Verified by *gwo*

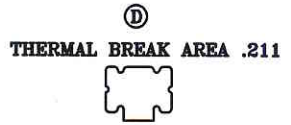

▷.010 R. X .010DEEPL.D. MARK NOTE: .060 TYP. WALL EXCEPT AS NOTED UNMARKED CORNERS .010 R.

CONTAINER	DIE RING	SPACER RING					
AREA .897	PORTS 1	HEX -					
WT/FT 1.076	V/P -	BOLSTER 1-2	D	ADD THERMAL BREAK AREA	TAS	2/21/05	
PERL 16.078	FLEE6042	DIE SIZE 9X5	C	REMOVED UNDERCUTS WT/FT. WAS 1.008, P:16.433	ED	3/14/03	
DWN. BY <i>Hilda</i>	DATE 3/14/03	MAT'L 6063-T6	B	REMOVED .125 STEP WT/FT. WAS 1.008, P:16.416	ED	7/19/03	
CHEK. BY	DATE	STANDARD TOLERANCES UNLESS OTHERWISE NOTED	LET.	REVISION	BY	DATE	
SIERRA ALUMINUM COMPANY 2345 Fleetwood Drive Riverside, California 92509 (909)781-7800 FAX (909)781-7864		CUSTOMER FLEETWOOD ALUMINUM PRODUCTS, INC.		SCALE 3:1	PART NO. 05P11		
PART NAME ZEE BAR				DIE NO. H-006733			

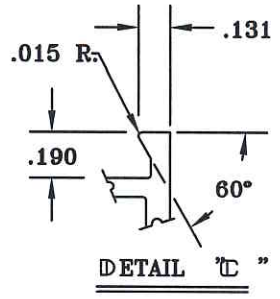
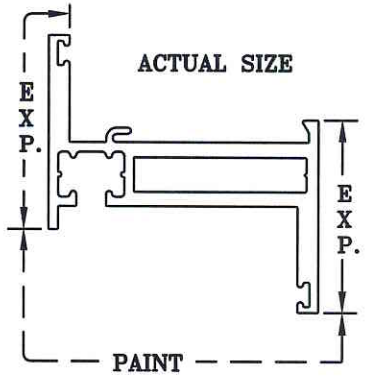

CUSTOMER: FLEETWOOD ALUMINUM PART NAME: 5000 INSIDE GLAZE PERIM. (NAIL-ON)
 PART NUMBER: 05P88

REV	REVISIONS	BY	DATE
	MATERIAL ADDED-SEE ACTUAL SIZE	CD	3.11.03
	SEE BELOW	CD	2.13.09
	NOW A HOLLOW DIE/.413 WAS .625/R.031(12) WAS R.031(10)	CD	3.31.09
	REDRAWN	CD	4.8.09

TB CAVITY TYPE CC
 AREA SQ" .210
 VOLUME CUBIC"/FT. 2.520

Engineering Evaluation Laboratories Inc
 Dimensional Complies with Drawing
 Conditions Noted - TEL # 01991057
 6-14-14 Verified by *gjd*

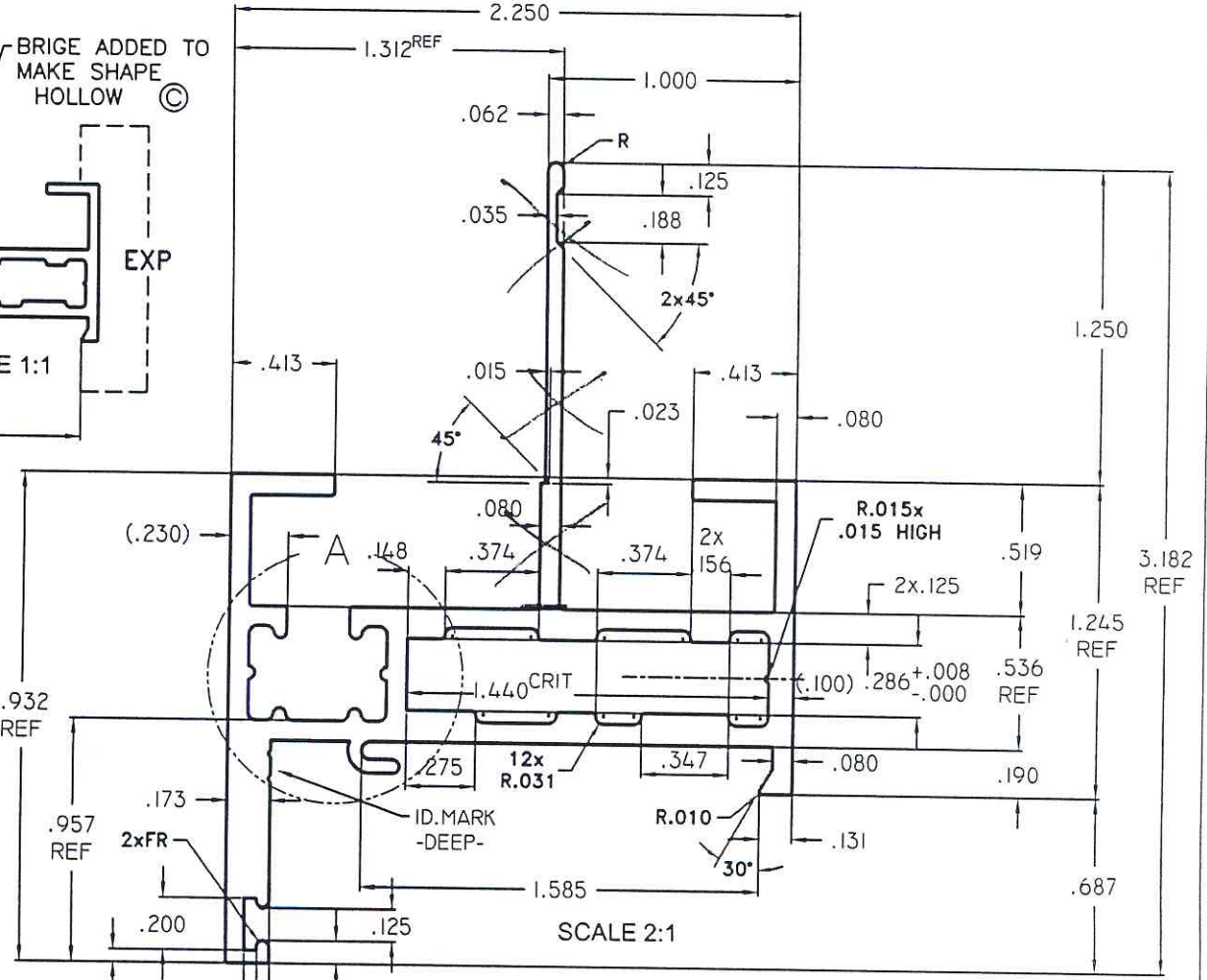
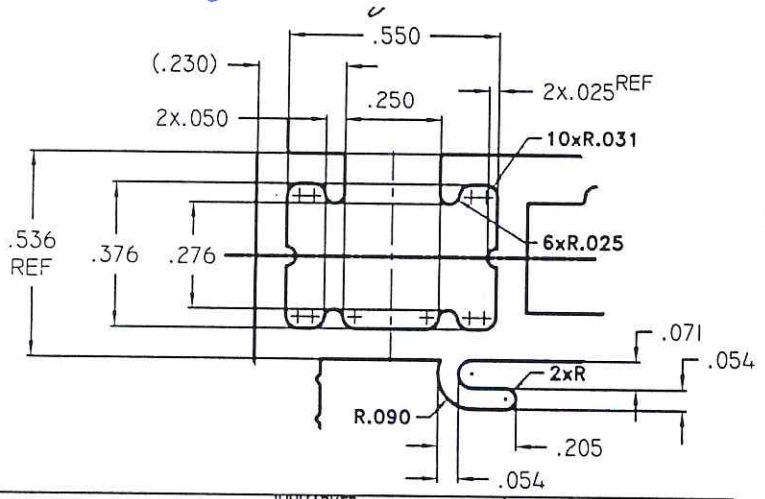
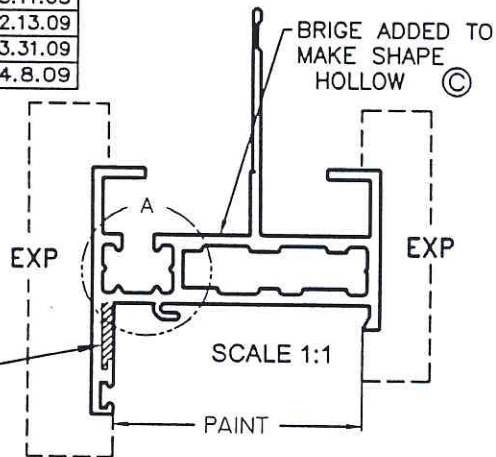

MARKED WALLS: .080		UNMARKED CORNERS: R.010	UNMARKED FILLETS: R.010
UNLESS OTHERWISE SPECIFIED, STANDARD ALUMINUM ASSOCIATION TOLERANCES APPLY • FRONTIER ID. MARK: TWO .010 R x .100 APART			
SHAPE: A	PRESS 4	DWN CD	Frontier Aluminum Corp.
WIDTH: 1.113	PORTS 11x7-2H	DATE 4.17.2014	2480 Railroad St. Corona, Ca
DEPTH: 1.21.012	W/P HOLLOW	D 5278	Ph: [951] 735-1770 Fax 735-1895
TOR 19	BKR. HOLLOW	CLASS HOLLOW	http://www.frontier-aluminum.com
THICKNESS: .D. 3.57	BOL STD-2	17.205	
NO: 0201/92	RATIO: PRESS 1:	PRESS 2:	PRESS 3:
ALLOY & TEMPER: 6063-T6		DIE NO. 5278	REV. C1

