

3
2 **HORIZONTAL CROSS SECTION**
Shown w/ Steel Stud option

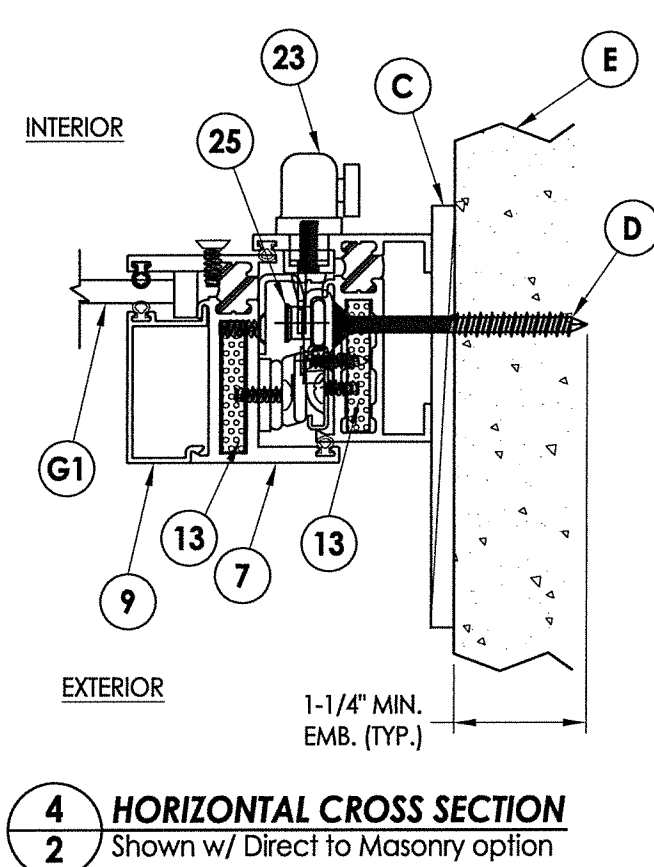

4
2 **HORIZONTAL CROSS SECTION**
Shown w/ Direct to Masonry option

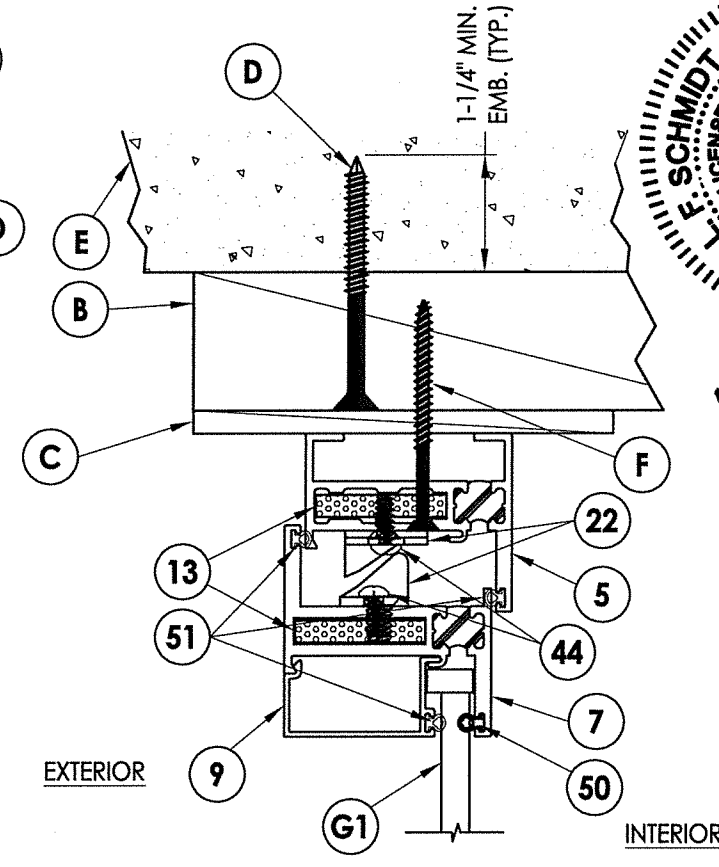

5
2 **VERTICAL CROSS SECTION**
Shown w/ 2X Buck Construction

NOTE:
1. Sheet Metal Screws must penetrate a min. of 3 threads through at least two (2) sheets of metal. Maintain a minimum 1/2" edge distance.

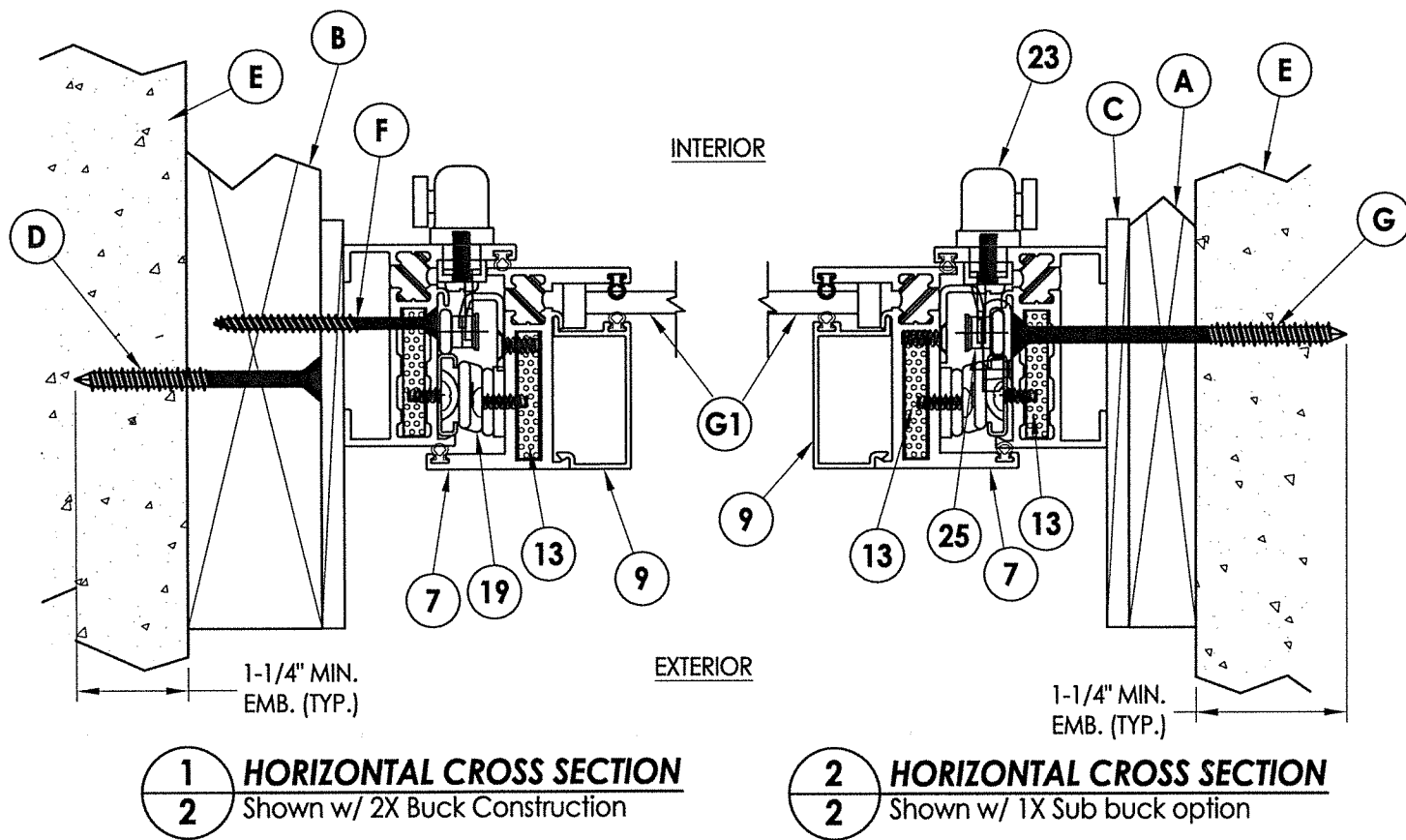

1
2 **HORIZONTAL CROSS SECTION**
Shown w/ 2X Buck Construction

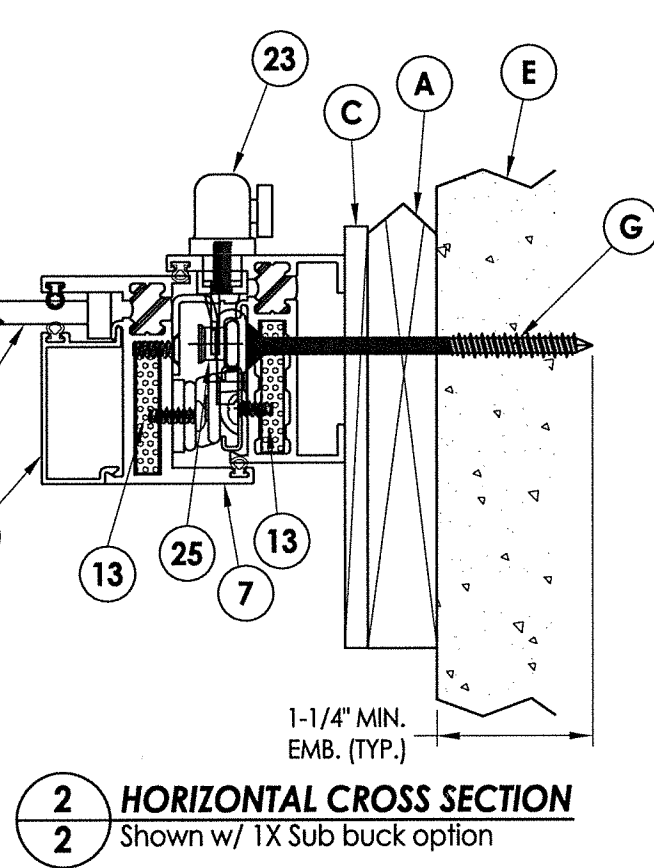

2
2 **HORIZONTAL CROSS SECTION**
Shown w/ 1X Sub buck option

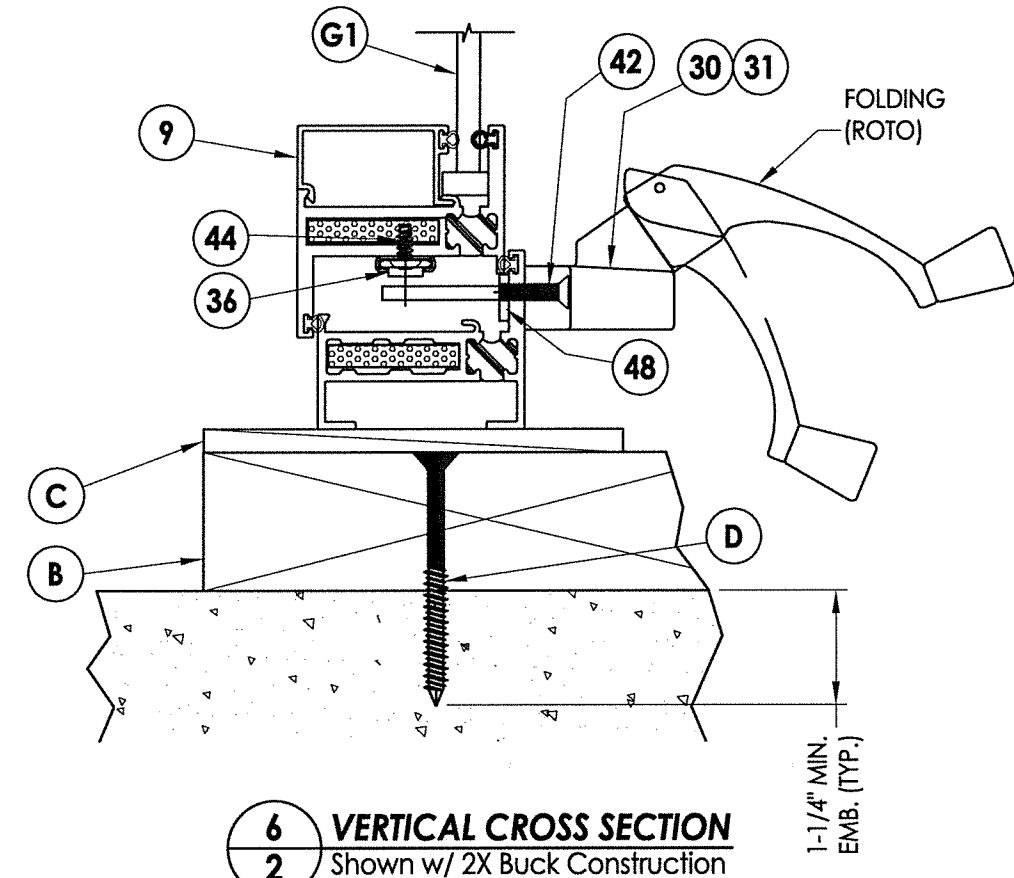

6
2 **VERTICAL CROSS SECTION**
Shown w/ 2X Buck Construction

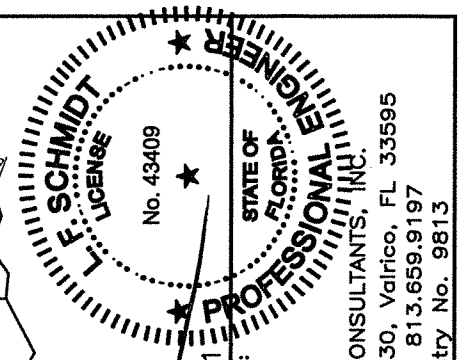

December 8, 2021
Documents Prepared By:
Lyndon F. Schmidt
P.E. No. 43409
R.W. BUILDING CONSULTANTS, INC.
P.O. Box 230, Vairico, FL 33595
Phone No.: 813.659.9197
FBPE Registry No. 9813

PRODUCT:	FLEETWOOD WINDOWS AND DOORS
PART OR ASSEMBLY:	HORIZONTAL AND VERTICAL CROSS SECTIONS

NO.	DATE	DESCRIPTION	BY
5	12/08/21	SERIES NAME CHANGE	LFS
4	8/10/20	UPDATE TO 7th ED. (2020) FBC	DAC
3	8/07/17	UPDATE TO 6TH ED. (2017) FBC	LFS
2	8/22/16	RENUMBER DRAWINGS	JK
1	1/22/15	UPDATE TO 5TH ED. (2014) FBC	LFS

DATE:	4/28/14
SCALE:	N.T.S.
DWG. BY:	JK
CHK. BY:	LFS
DRAWING NO.:	FL-14907.5
SHEET	2 OF 6

NOTE:
1. Item #35 located 17"
from each end (2) total.

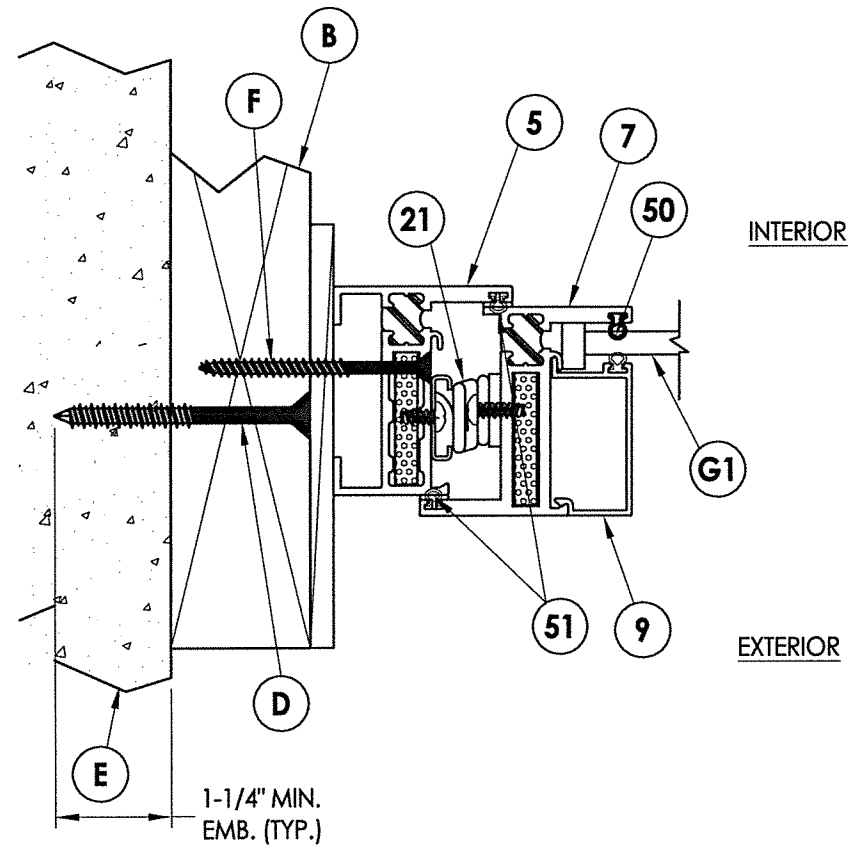
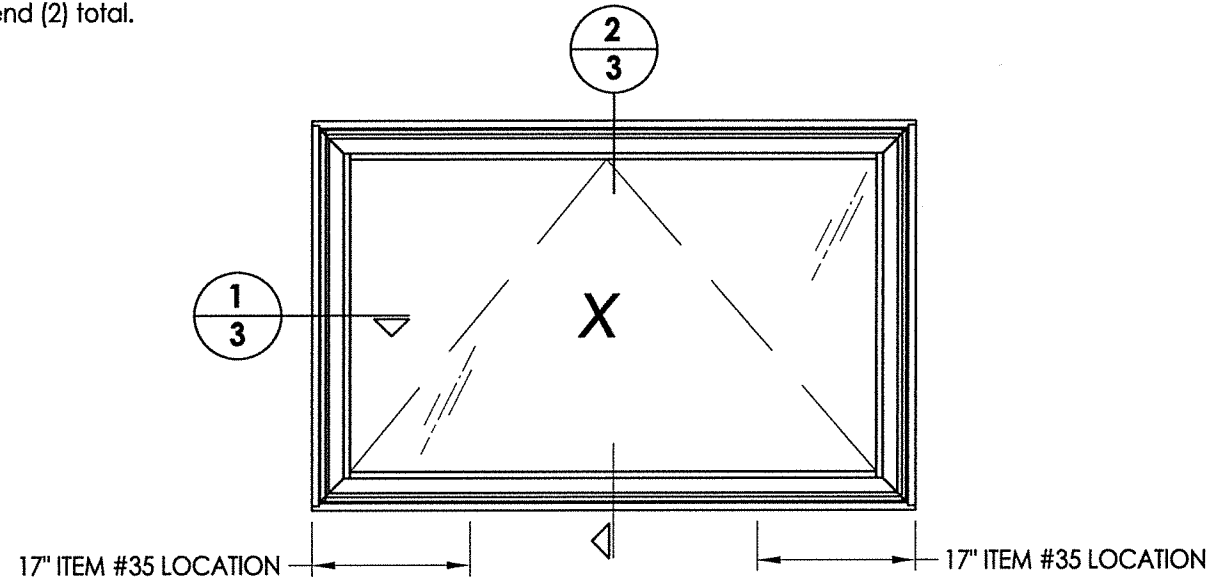

1 **HORIZONTAL CROSS SECTION**
3 Shown w/ 2X Buck Construction

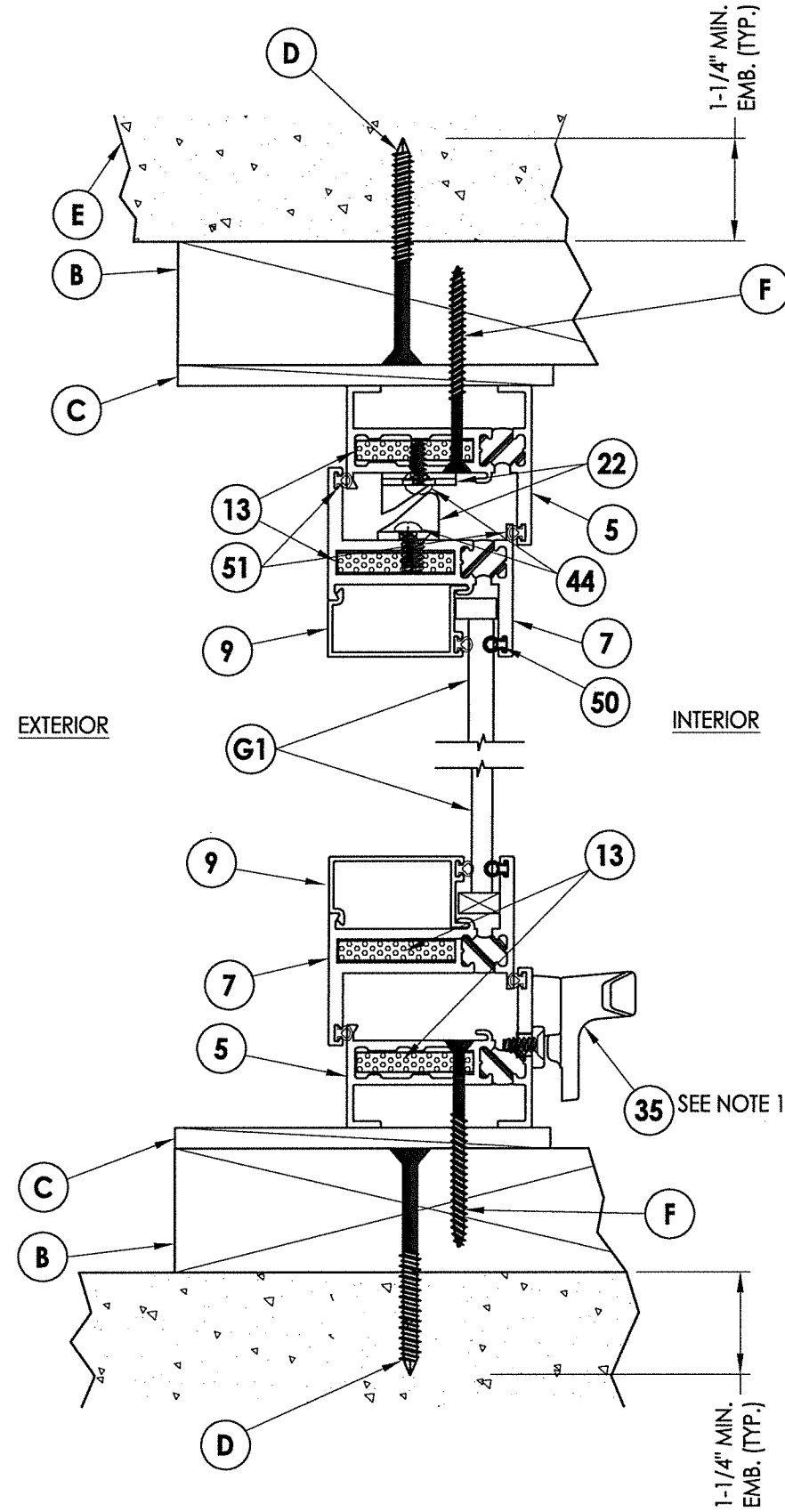

2 **VERTICAL CROSS SECTION**
3 Shown w/ 2X Buck Construction

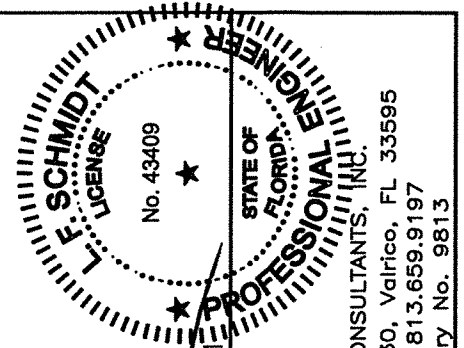

December 8, 2021
Documents Prepared By:
Lyndon F. Schmidt
P.E. No. 43409

RW BUILDING CONSULTANTS, INC.
P.O. Box 230, Valrico, FL 33595
Phone No.: 813.659.9197
FBPE Registry No. 9813

PRODUCT:
FLEETWOOD WINDOWS AND DOORS
PART OR ASSEMBLY:
HORIZONTAL AND VERTICAL
CROSS SECTIONS

NO.	DATE	DESCRIPTION	BY
5	12/08/21	SERIES NAME CHANGE	LFS
4	8/10/20	UPDATE TO 7th ED. (2020) FBC	DAC
3	8/07/17	UPDATE TO 6TH ED. (2017) FBC	FBC
2	8/22/16	RENUMBER DRAWINGS	JK
1	1/22/15	UPDATE TO 5TH ED. (2014) FBC	LFS

DATE: 4/28/14

SCALE: N.T.S.

DWG. BY: JK

CHK. BY: LFS

DRAWING NO.:
FL-14907.5

SHEET 3 OF 6

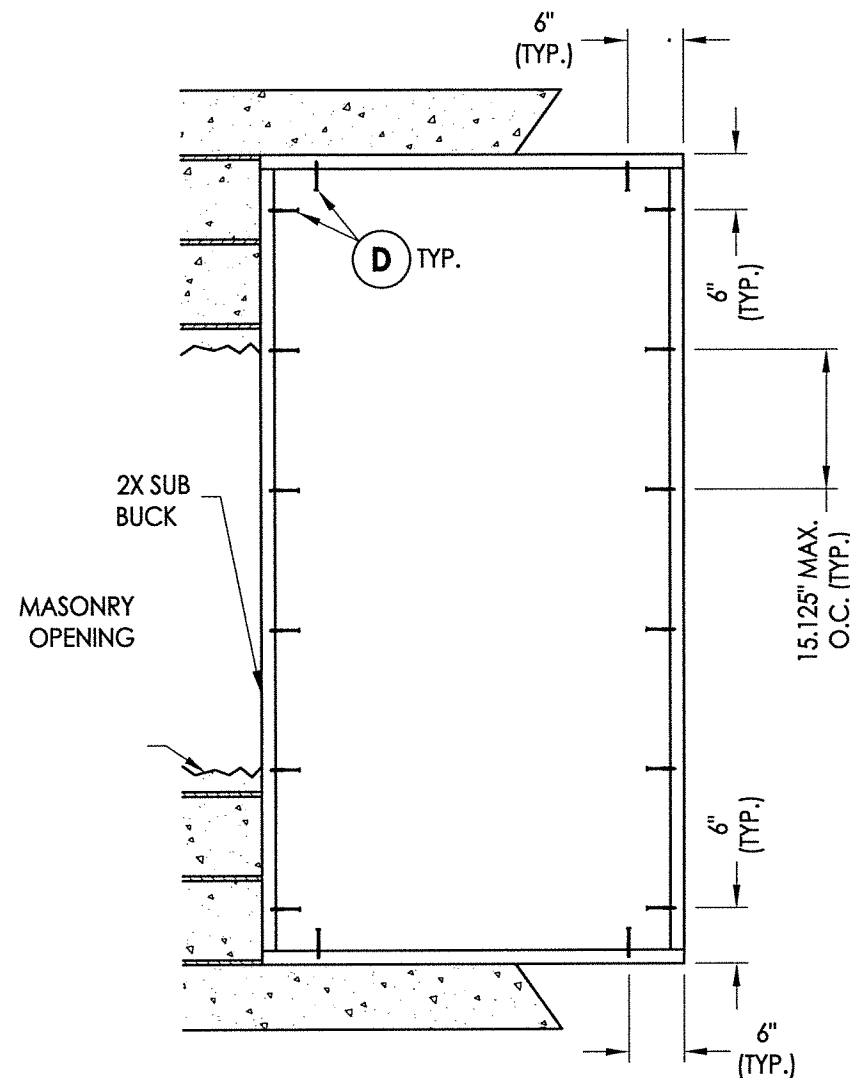

2X BUCK ANCHORING
42" X 84" Max Size

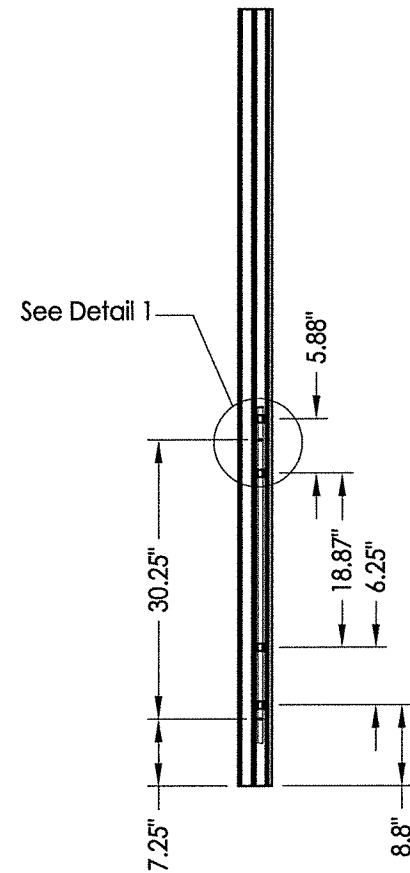

LOCK JAMB
2 Point Lock

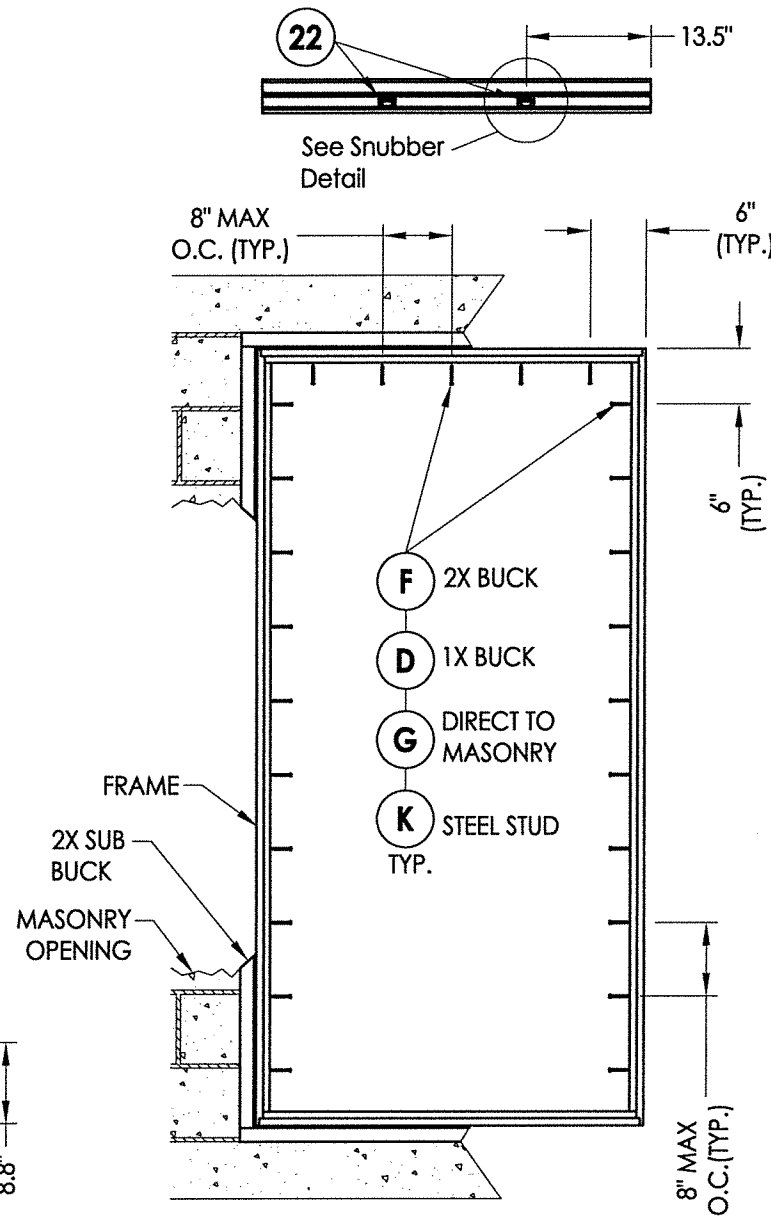

FRAME MOUNT ANCHORING
42" X 84" Max Size

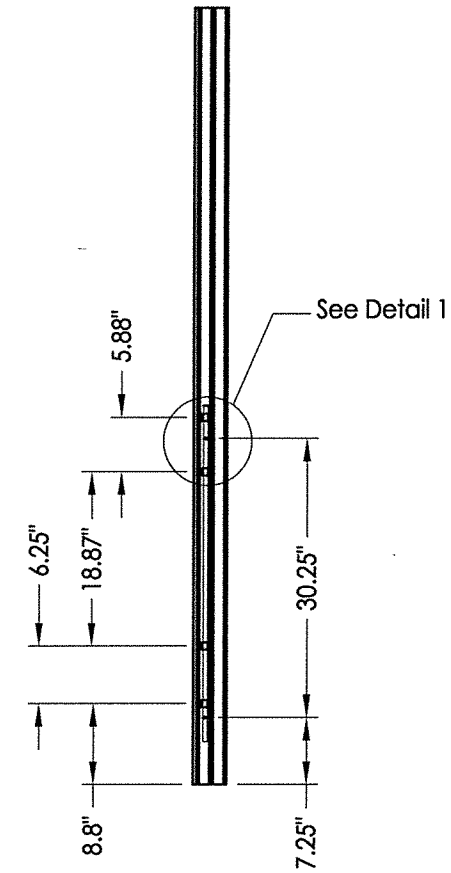

LOCK JAMB
2 Point Lock

CONCRETE ANCHOR NOTES:

- Concrete anchor locations at the corners may be adjusted to maintain the min. edge distance to mortar joints.
- Concrete anchor locations noted as "MAX. ON CENTER" must be adjusted to maintain the min. edge distance to mortar joints, additional concrete anchors may be required to ensure the "MAX. ON CENTER" dimension are not exceeded.
- Concrete anchor table:

ANCHOR TYPE	ANCHOR SIZE	MIN. EMBEDMENT	MIN. CLEARANCE TO MASONRY EDGE	MIN. CLEARANCE TO ADJACENT ANCHOR
ITW TAPCON®	1/4"	1-1/4"	2"	4"
DeWALT ULTRACON®	1/4"	1-1/4"	1"	4"

WOOD SCREW INSTALLATION NOTES:

- Maintain a minimum 5/8" edge distance, 1" end distance, & 1" o.c. spacing of wood screws to prevent the splitting of wood.

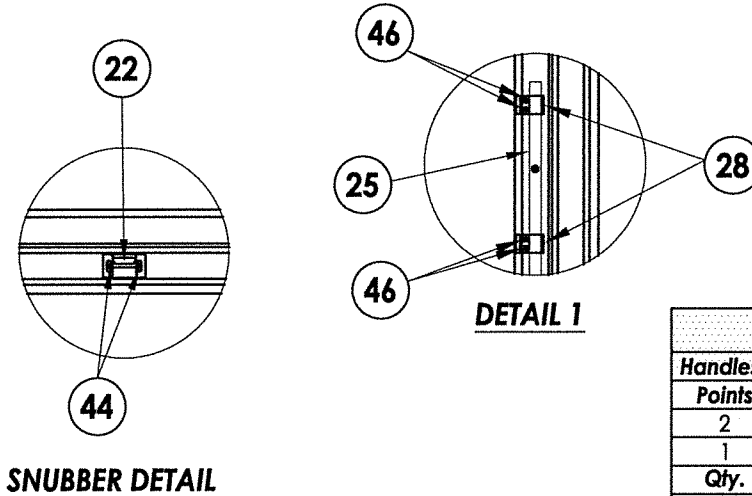

SNUBBER DETAIL

HARDWARE TABLE			
Points	Description	Height	*Cam locks can be used in conjunction with multipoint lock or in lieu of multipoint locks
2	Multipoint	> 50"	
1	Multipoint	≤ 50"	
Qty.			
2	Cam*	≤ 50"	

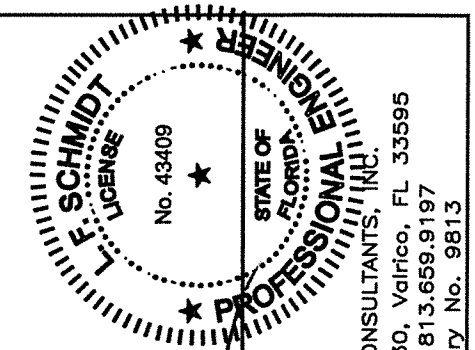

December 8, 2021
 Documents Prepared By:
 Lyndon F. Schmidt
 P.E. No. 43409
 RW BUILDING CONSULTANTS, INC.
 P.O. Box 230, Valrico, FL 33595
 Phone No.: 813.659.9197
 FBPE Registry No. 9813

PRODUCT:	FLEETWOOD WINDOWS AND DOORS
PART OR ASSEMBLY:	BUCK & FRAME ANCHORING
REVISIONS	
NO.	DATE
5	12/08/21
4	8/10/20
3	8/07/17
2	8/22/16
1	1/22/15
DATE: 4/28/14	
SCALE: N.T.S.	
DWG. BY:	JK
CHK. BY:	LFS
DRAWING NO.:	FL-14907.5
SHEET	4 OF 6

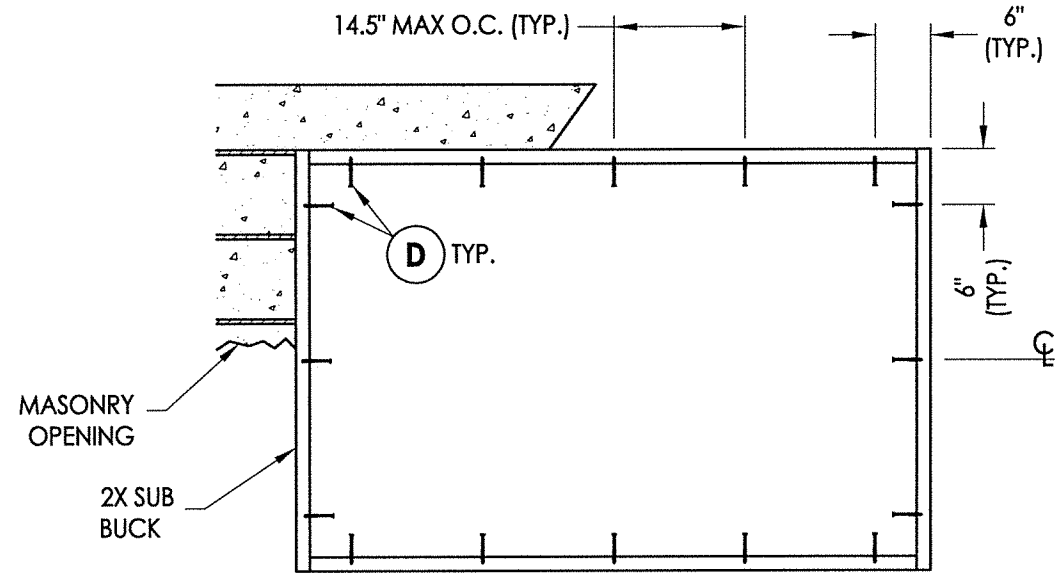

2X BUCK ANCHORING
65" X 42" Max Size

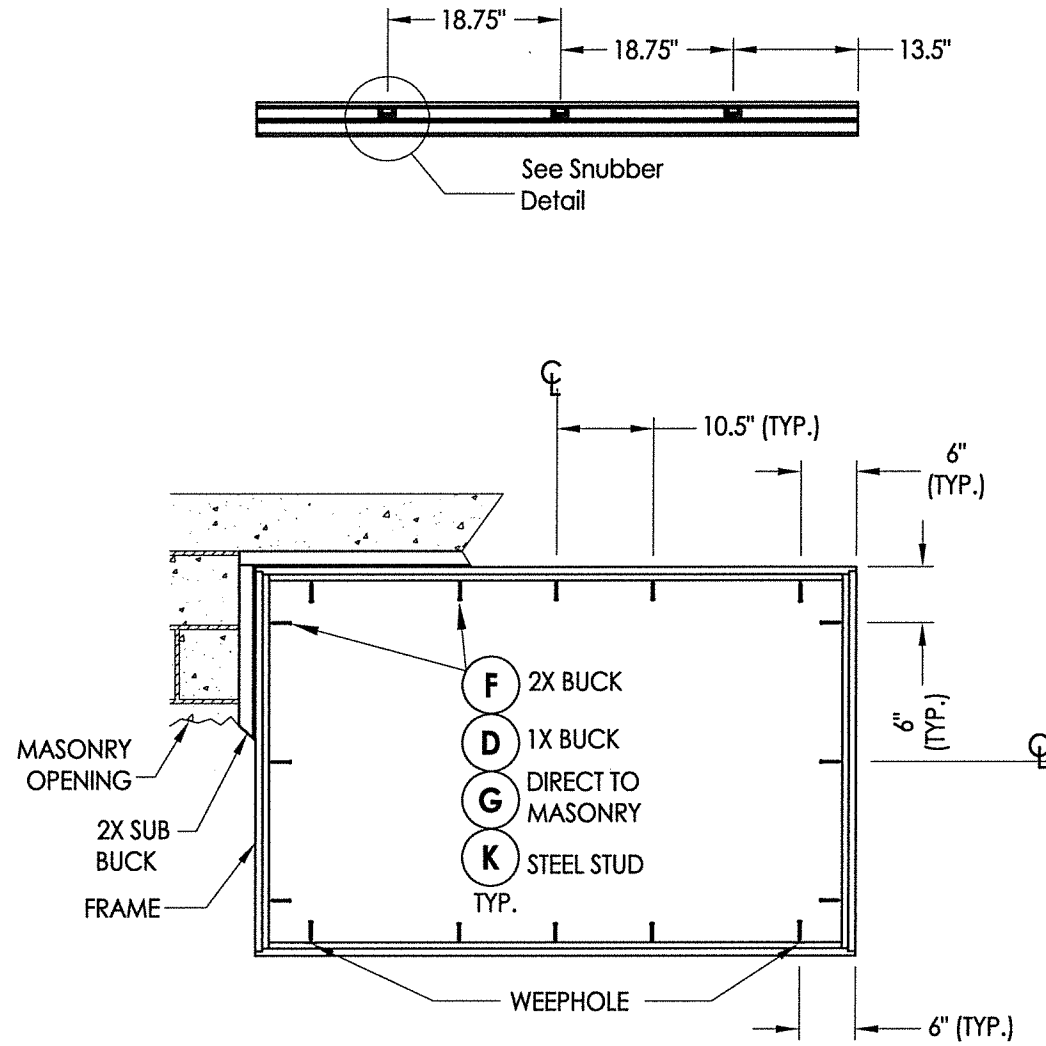

FRAME MOUNT ANCHORING
65" X 42" Max Size

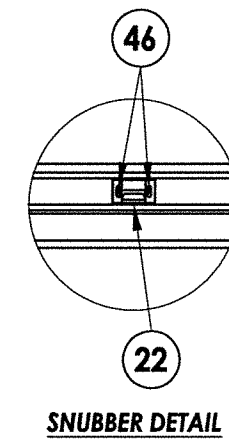

SNUBBER DETAIL

CONCRETE ANCHOR NOTES:

1. Concrete anchor locations at the corners may be adjusted to maintain the min. edge distance to mortar joints.
2. Concrete anchor locations noted as "MAX. ON CENTER" must be adjusted to maintain the min. edge distance to mortar joints, additional concrete anchors may be required to ensure the "MAX. ON CENTER" dimension are not exceeded.
3. Concrete anchor table:

ANCHOR TYPE	ANCHOR SIZE	MIN. EMBEDMENT	MIN. CLEARANCE TO MASONRY EDGE	MIN. CLEARANCE TO ADJACENT ANCHOR
ITW TAPCON®	1/4"	1-1/4"	2"	4"
DeWALT ULTRACON+®	1/4"	1-1/4"	1"	4"

WOOD SCREW INSTALLATION NOTES:

1. Maintain a minimum 5/8" edge distance, 1" end distance, & 1" o.c. spacing of wood screws to prevent the splitting of wood.

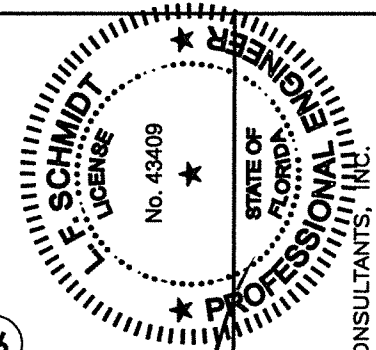

December 8, 2021
 Documents Prepared By:
 Lyndon F. Schmidt
 P.E. No. 43409
 R.W. BUILDING CONSULTANTS, INC.
 P.O. Box 230, Valrico, FL 33595
 Phone No.: 813.659.9197
 FBPE Registry No. 9813

PRODUCT:
 FLEETWOOD WINDOWS AND DOORS
 PART OR ASSEMBLY:
 BUCK & FRAME ANCHORING

NO.	DATE	REVISIONS
5	12/08/21	SERIES NAME CHANGE
4	8/10/20	UPDATE TO 7TH ED. (2020) FBC DAC
3	8/07/17	UPDATE TO 6TH ED. (2017) FBC LFS
2	8/22/16	RENUMBER DRAWINGS
1	1/22/15	UPDATE TO 5TH ED. (2014) FBC LFS
		BY JK

DATE: 4/28/14
 SCALE: N.T.S.
 DWG. BY: JK
 CHK. BY: LFS
 DRAWING NO.: FL-14907.5
 SHEET 5 OF 6

BILL OF MATERIALS		
ITEM #	DESCRIPTION	MATERIAL
A	1X BUCK SG >= 0.55	WOOD
B	2X BUCK SG >= 0.55	WOOD
C	1/4" MAX. SHIM SPACE	-
D	1/4" X 2-3/4" DeWALT OR ITW PFH CONCRETE SCREW	STEEL
E	MASONRY - 3,000 PSI MIN. CONCRETE CONFORMING TO ACI 301 OR HOLLOW BLOCK CONFORMING TO ASTM C90	CONCRETE
F	#10 X 2" PPH WOOD SCREW (1-1/4" MIN. EMBEDMENT)	STEEL
G	1/4" X 3-3/4" DeWALT OR ITW PFH CONCRETE SCREW	STEEL
H	#10 X 2-3/4" PPH WOOD SCREW	STEEL
K	#10 PFH SELF-DRILLING SMS	STEEL
X	STEEL STUD Min. Thk .033" (ASTM A653 GRADE 33 Fy=33 Ksi Min, Fu=45 Ksi Min)	STEEL
3	THERMAL BREAK ("LIQUID POLYURETHANE" by Azon USA, Inc.)	-
5	BLOCK FRAME (350-T)	6063-T6 ALUM
7	ZEE BAR (PANEL)	6063-T6 ALUM
9	GLASS STOP (1/4")	6063-T6 ALUM
12	SHEAR BLOCK	6061-T6 ALUM
13	CORNER KEY	6063-T6 ALUM
19	2 BAR HINGE	SS
21	4 BAR HINGE	SS
22	SNUBBER-COMMERCIAL PULL-IN BLOCK	SS
23	MULTIPOINT LOCK HANDLE	SS
24	1 POINT LOCKING BAR (TRUTH)	SS
25	2 POINTS LOCKING BAR (TRUTH)	SS
28	TIE BAR GUIDE (TRUTH)	-
29	KEEPER (TRUTH)	SS
30	CASEMENT ROTOR GEAR 13.5" (TRUTH)	SS
31	CASEMENT ROTOR GEAR 9.5" (TRUTH)	SS
35	CAM HANDLE / STRIKE PLATE	SS
36	CASEMENT SS. TRACK (TRUTH)	SS
40	#10 X 1" PPH SMS	STEEL
42	MACHINE SCREW NO 10-32, FHP .75"	STEEL
43	SCREW NO 10, UFHP .5"	STEEL
44	SCREW NO 8, PHP, .50"	STEEL
46	SCREW NO 8, FHP, .750"	STEEL
48	BACK UP NUTS	STEEL
50	BULB VINYL (EPDM 70 DUROMETER)-TREMCO	-
51	MINI BULB VINYL (EPDM 70 DUROMETER)-TREMCO	-
55	SETTING BLOCK	-

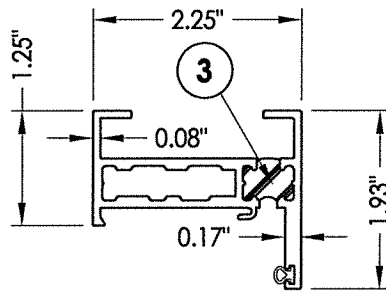

5 BLOCK FRAME

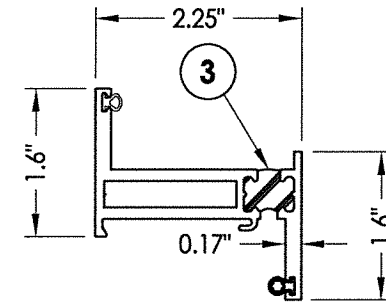

7 ZEE BAR (PANEL)

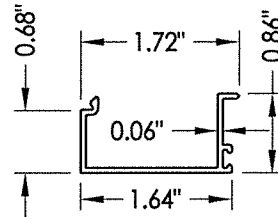

9 GLASS STOP 1/4"

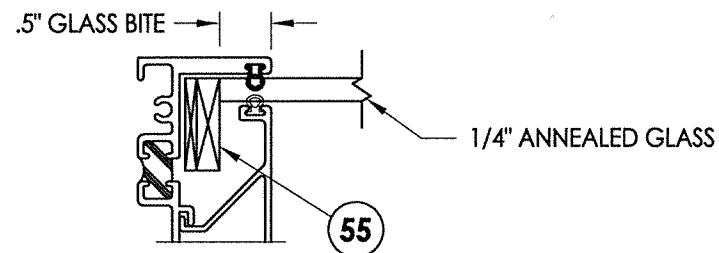

G1 GLAZING DETAIL

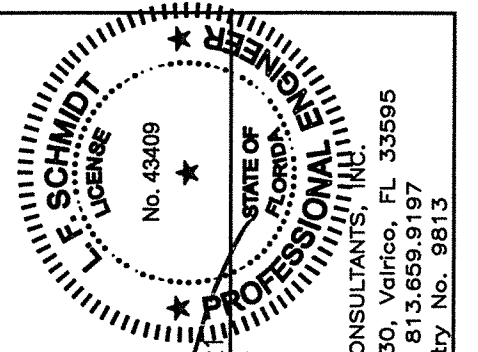

December 8, 2021
 Documents Prepared By:
 Lyndon F. Schmidt
 P.E. No. 43409
 R.W. BUILDING CONSULTANTS, INC.
 P.O. Box 230, Valrico, FL 33595
 Phone No.: 813.659.9197
 FBPE Registry No. 9813

PRODUCT: FLEETWOOD WINDOWS AND DOORS
 PART OR ASSEMBLY: BILL OF MATERIALS, GLAZING DETAIL AND COMPONENTS

NO.	DATE	REVISIONS
5	12/08/21	SERIES NAME CHANGE
4	8/10/20	UPDATE TO 7th ED. (2020) FBC
3	8/07/17	UPDATE TO 6TH ED. (2017) FBC
2	8/22/16	RENUMBER DRAWINGS
1	1/22/15	UPDATE TO 5TH ED. (2014) FBC

DATE: 4/28/14
 SCALE: N.T.S.
 DWG. BY: JK
 CHK. BY: LFS
 DRAWING NO.: FL-14907.5
 SHEET 6 OF 6