

4-BAR HINGE

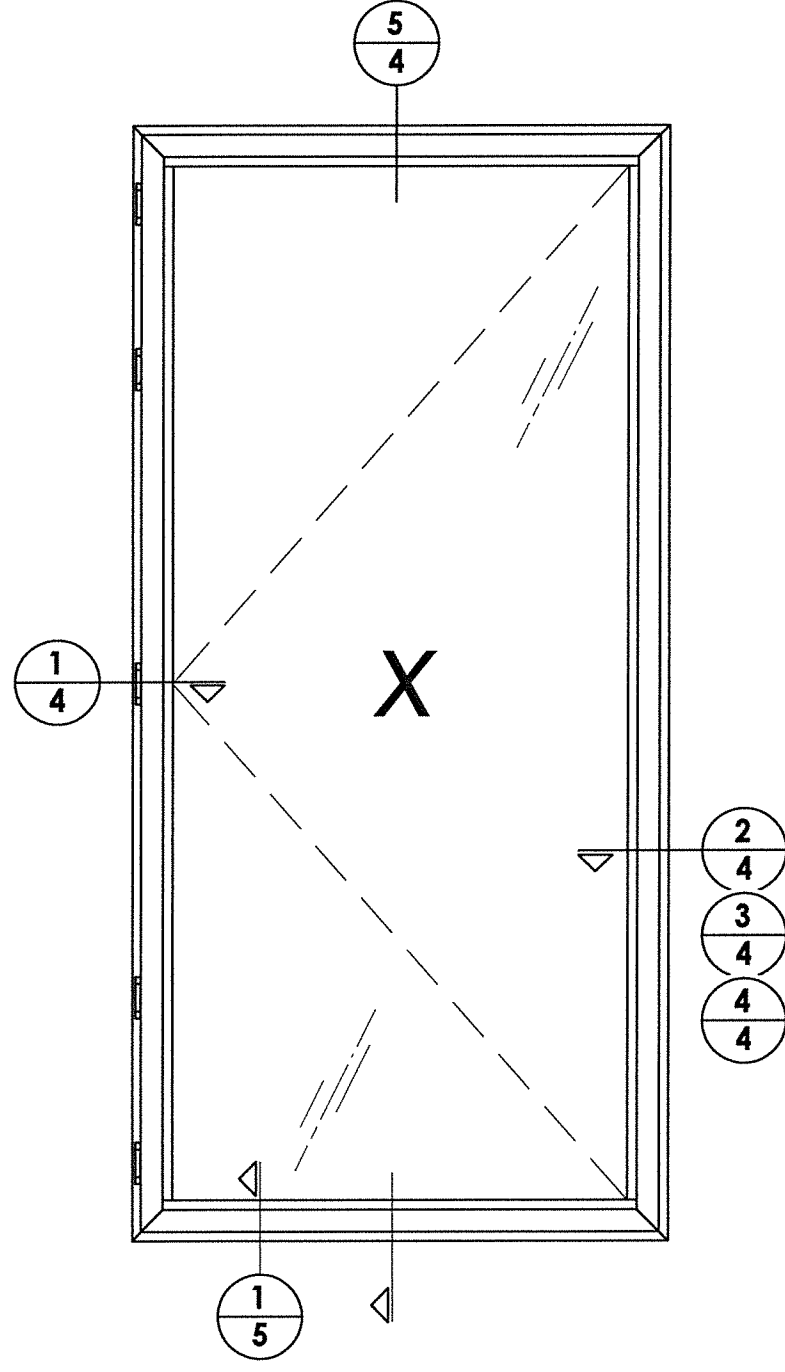

BUTT HINGE

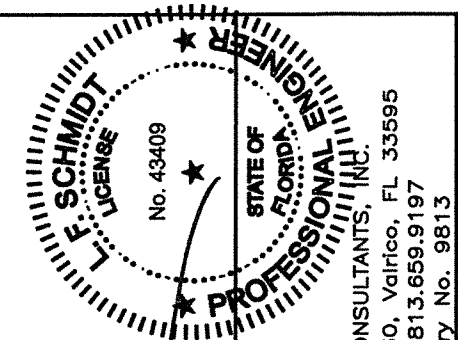

December 7, 2021
 Documents Prepared By:
 Lyndon F. Schmidt
 P.E. No. 43409

PRODUCT:
 FLEETWOOD WINDOWS & DOORS

PART OR ASSEMBLY:
 ELEVATIONS

NO.	DATE	REVISIONS	BY

DATE: 12/01/21
 SCALE: N.T.S.
 DWG. BY: LFS
 CHK. BY: RW
 DRAWING NO.:
 FL-14904.14
 SHEET 2 OF 9

RW
 BUILDING CONSULTANTS, INC.
 P.O. Box 230, Vairico, FL 33595
 Phone No.: 813.659.9197
 FBPE Registry No. 9813

Z:\Clients\Fleetwood PERMANENTVA - Florida Product Approvals\FL-14904 Casement\C - Drawings\FL-14904.dwg

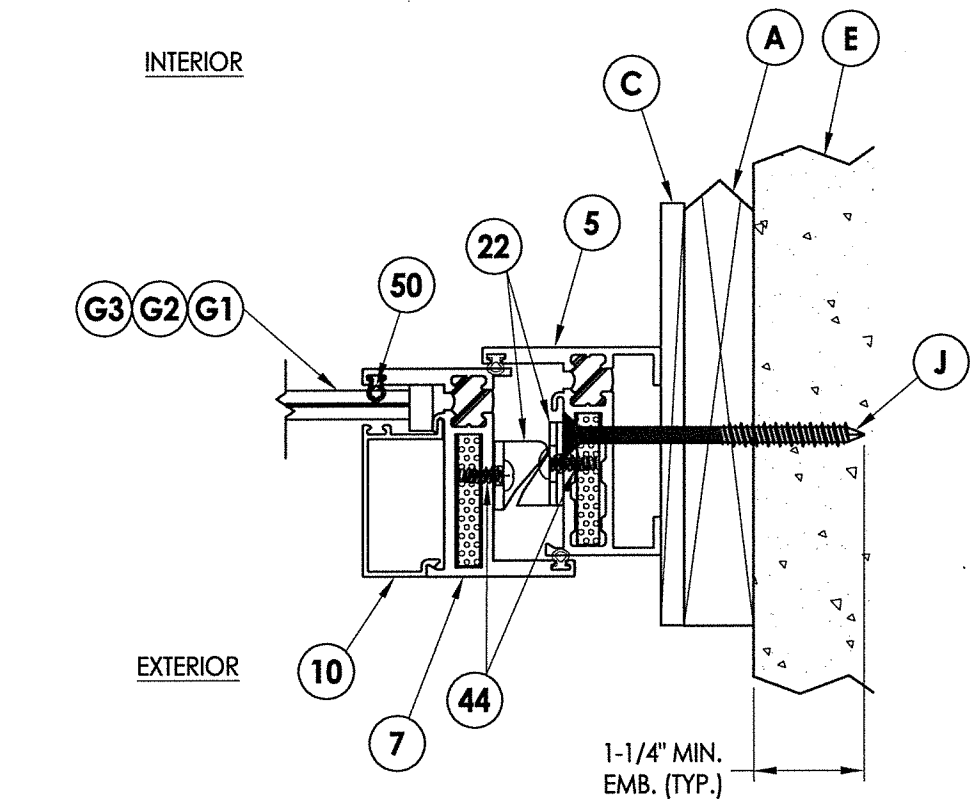

2 **HORIZONTAL CROSS SECTION**
3 Shown w/ 1X Sub buck option

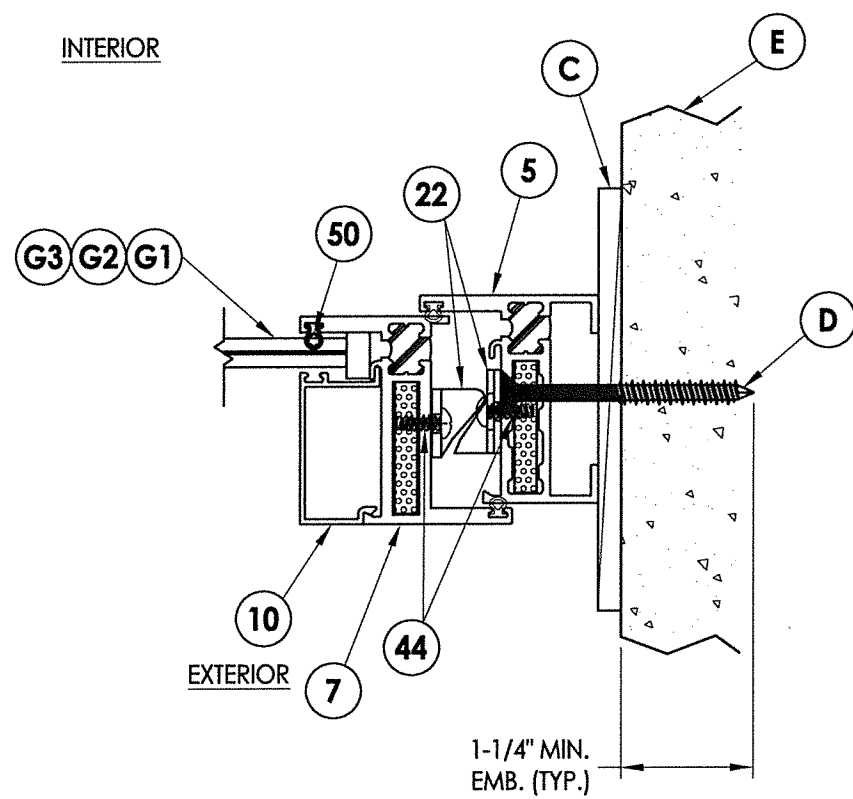

3 **HORIZONTAL CROSS SECTION**
3 Shown w/ Direct to Masonry option

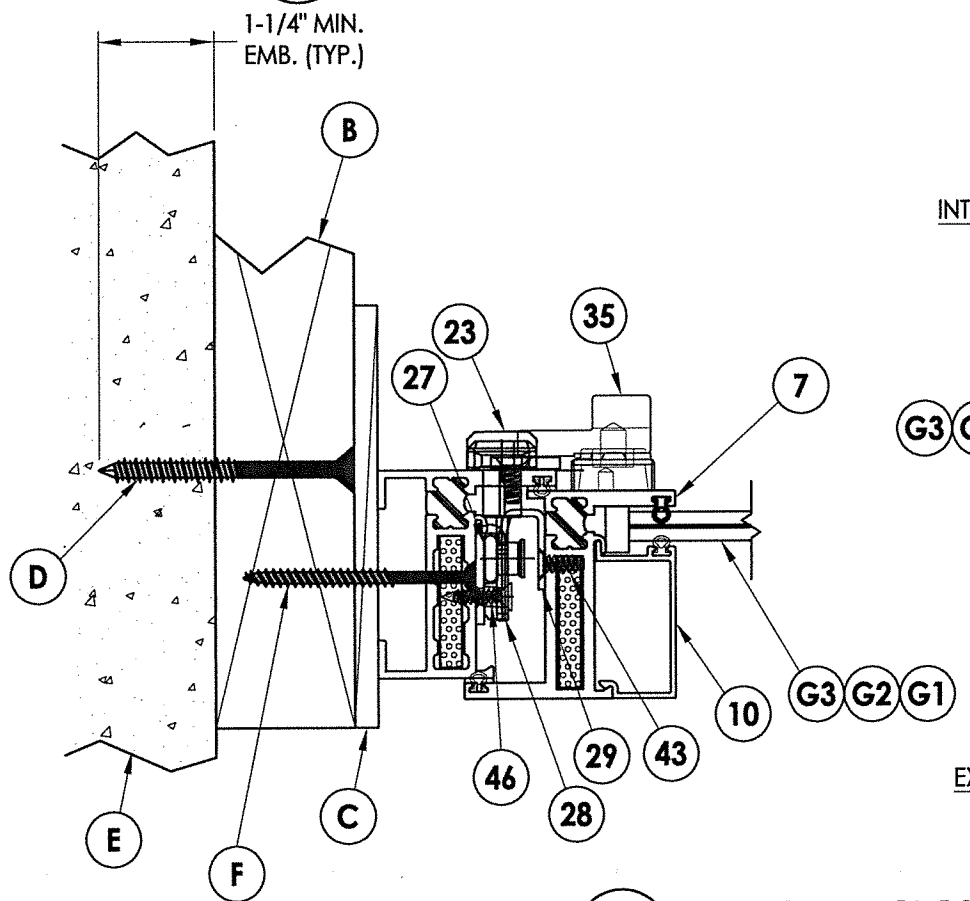

1 **HORIZONTAL CROSS SECTION**
3 Show w/ 2X Buck and Steel Stud options

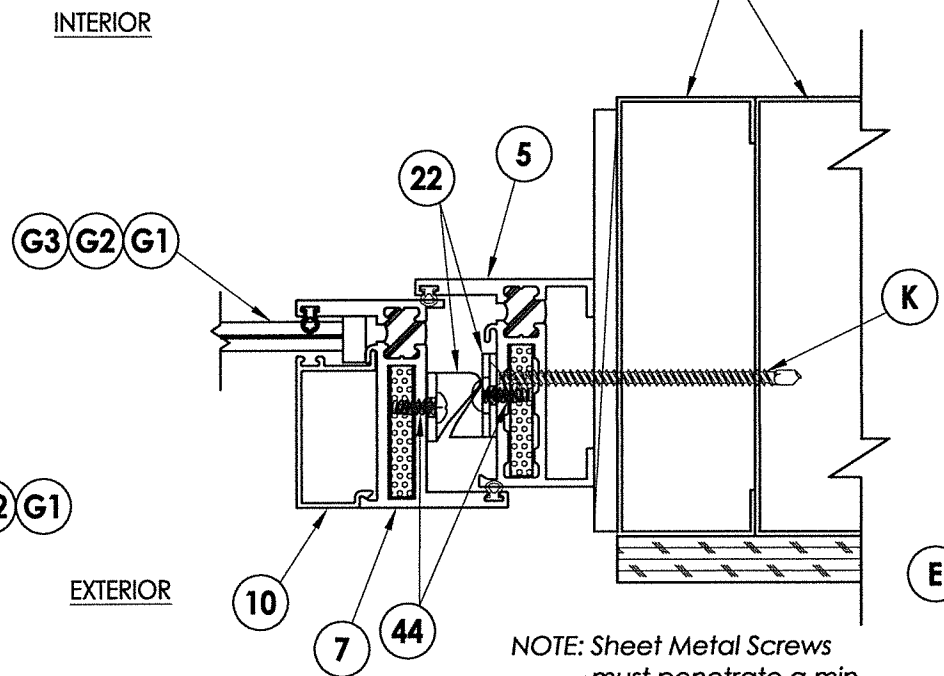

NOTE: Sheet Metal Screws must penetrate a min. of 3 threads through at least two (2) sheets of metal.

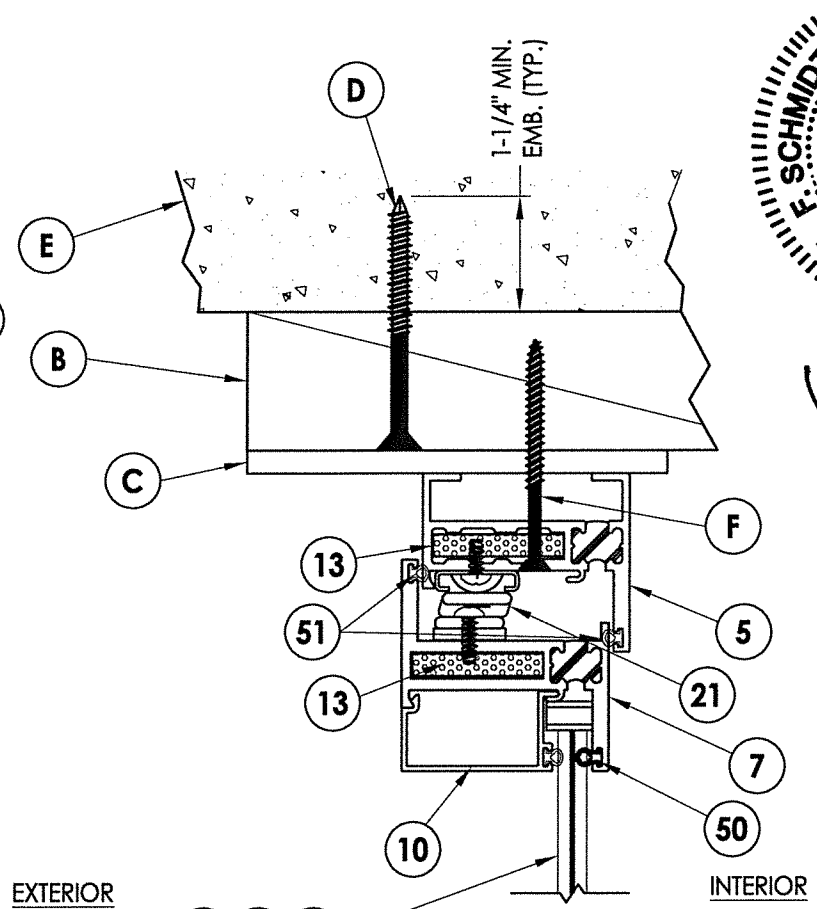

4 **VERTICAL CROSS SECTION**
3 Shown w/ 2X Buck Construction

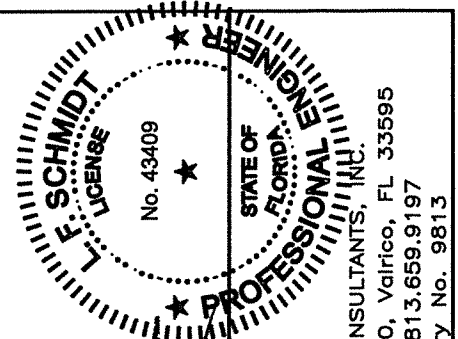

December 7, 2021
 Documents Prepared By:
 Lyndon F. Schmidt
 P.E. No. 43409
 R.W. BUILDING CONSULTANTS, INC.
 P.O. Box 230, Vairico, FL 33595
 Phone No.: 813.659.9197
 FBPE Registry No. 9813

PRODUCT: FLEETWOOD WINDOWS & DOORS
 PART OR ASSEMBLY: HORIZONTAL & VERTICAL CROSS SECTIONS

NO.	DATE	BY	REVISIONS

DATE: 12/01/21
 SCALE: N.T.S.
 DWG. BY: LFS
 CHK. BY: RW
 DRAWING NO.: FL-14904.14
 SHEET 3 OF 9

Z:\Clients\Fleetwood PERMANENTVA - Florida Product Approvals\FL-14904 Casement\C - Drawings\FL-14904 (2020)\FL-14904.14.dwg

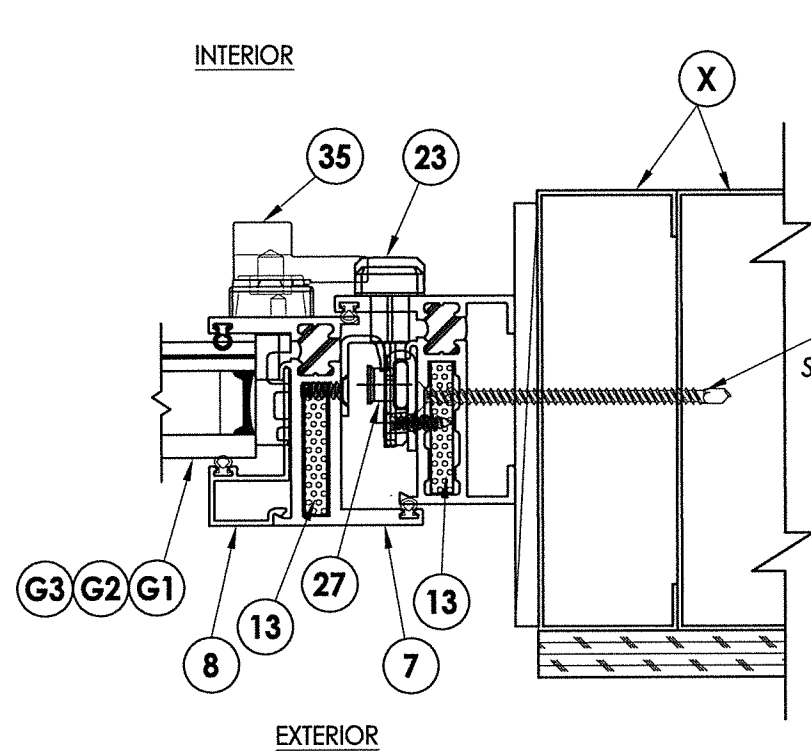

3 HORIZONTAL CROSS SECTION
4 Shown w/ Steel Stud option

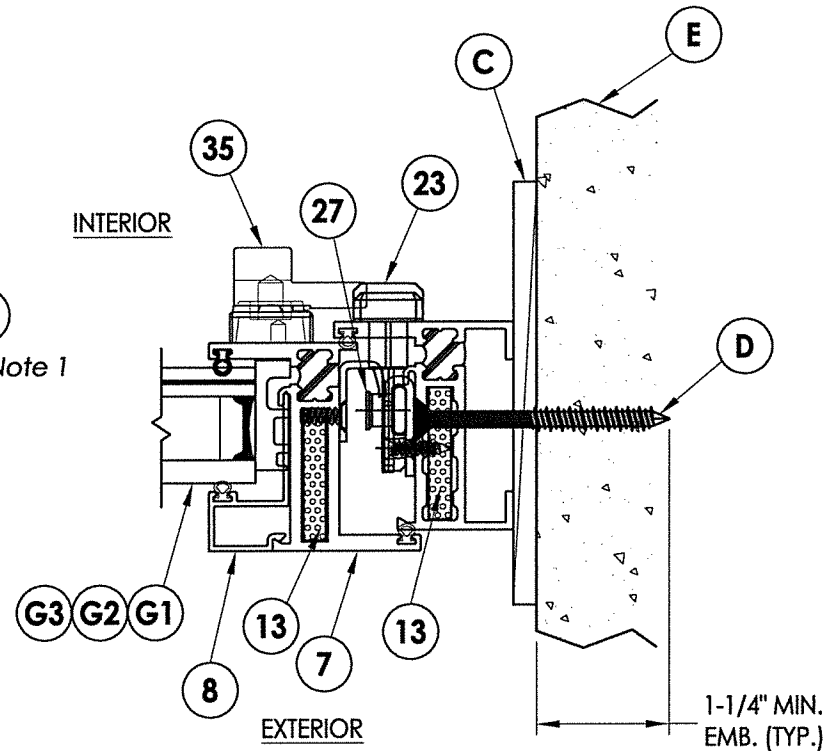

4 HORIZONTAL CROSS SECTION
4 Shown w/ Direct to Masonry option

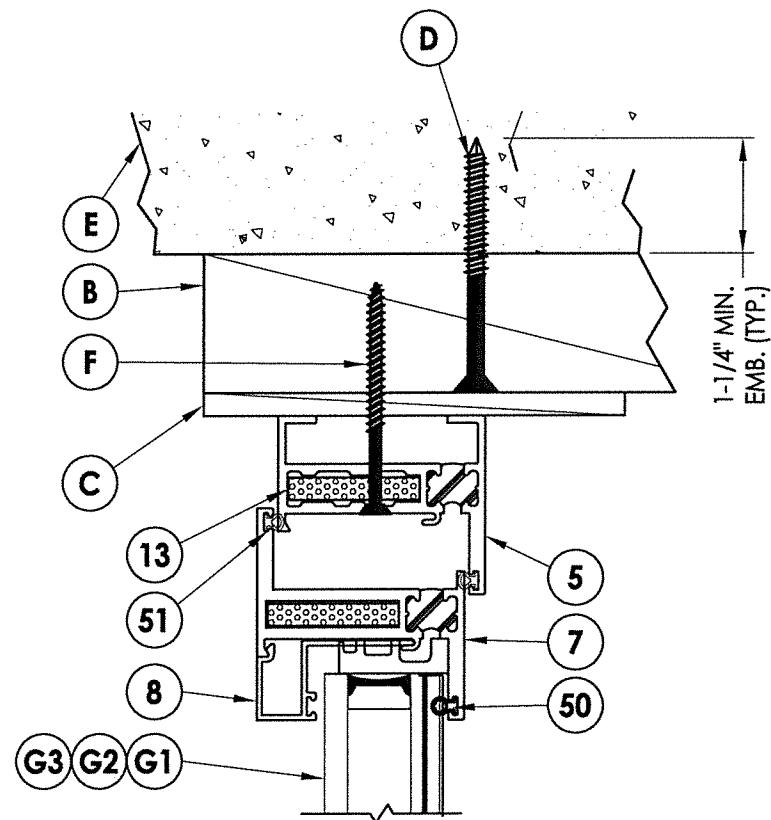

EXTERIOR INTERIOR

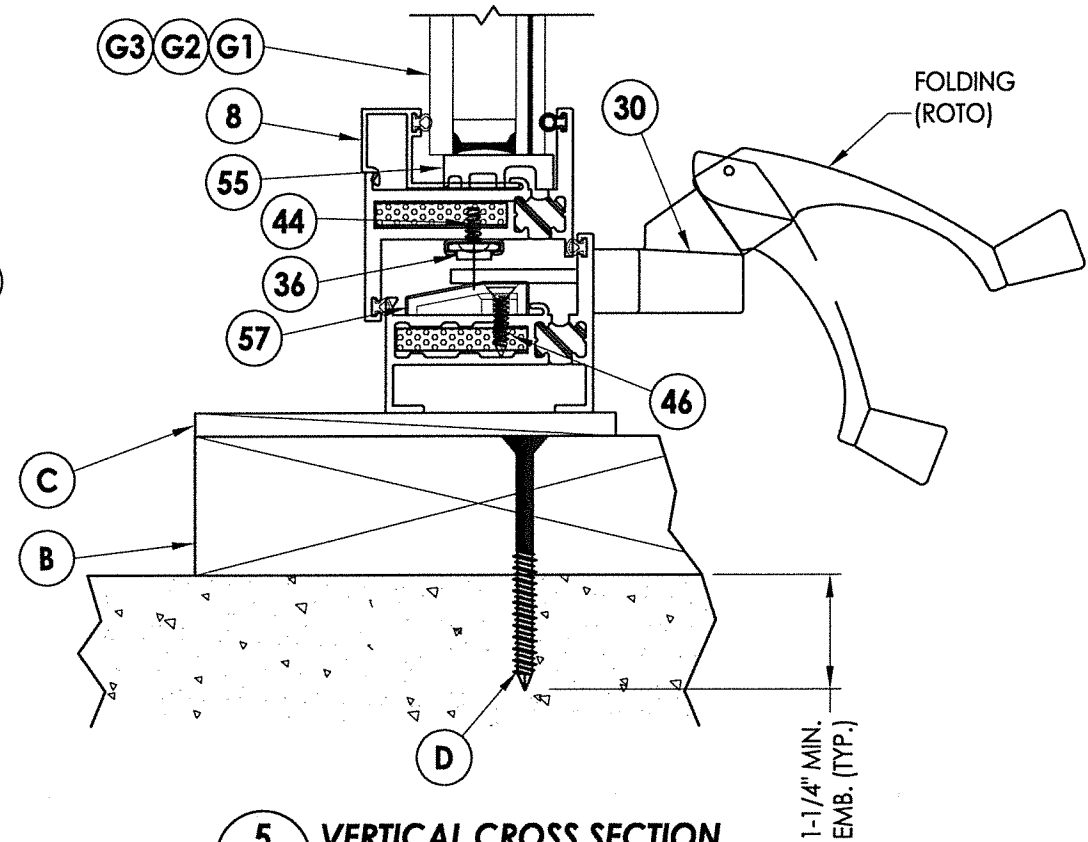

5 VERTICAL CROSS SECTION
4 Shown w/ 2X Buck Construction

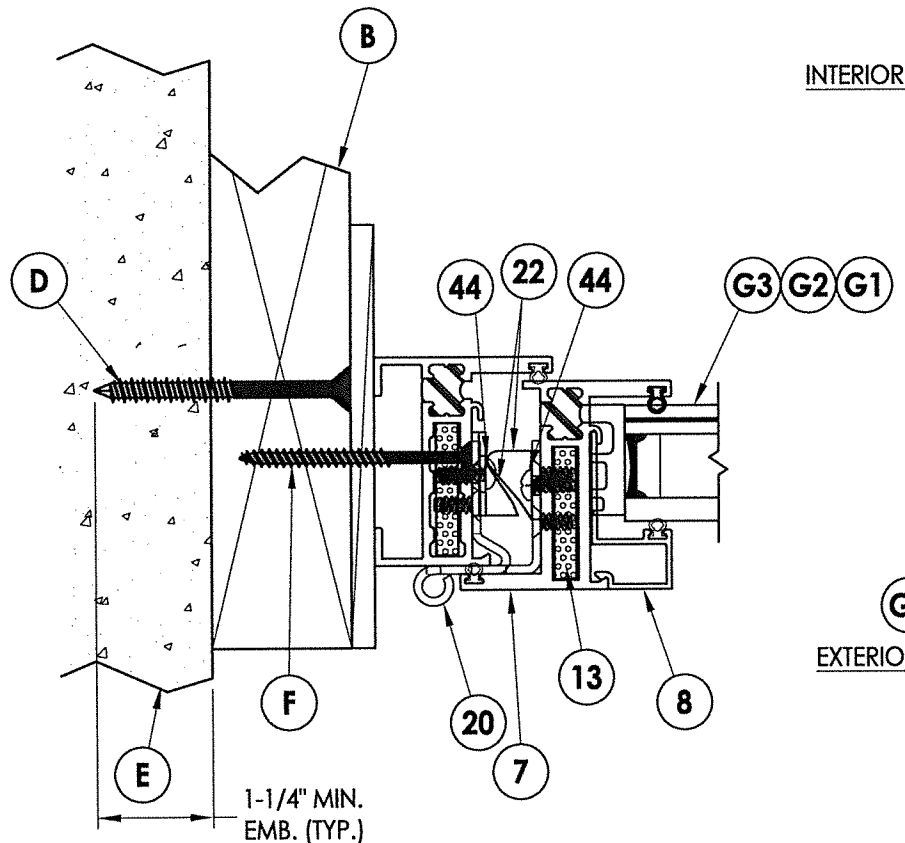

1 HORIZONTAL CROSS SECTION
4 Shown w/ 2X Buck Construction

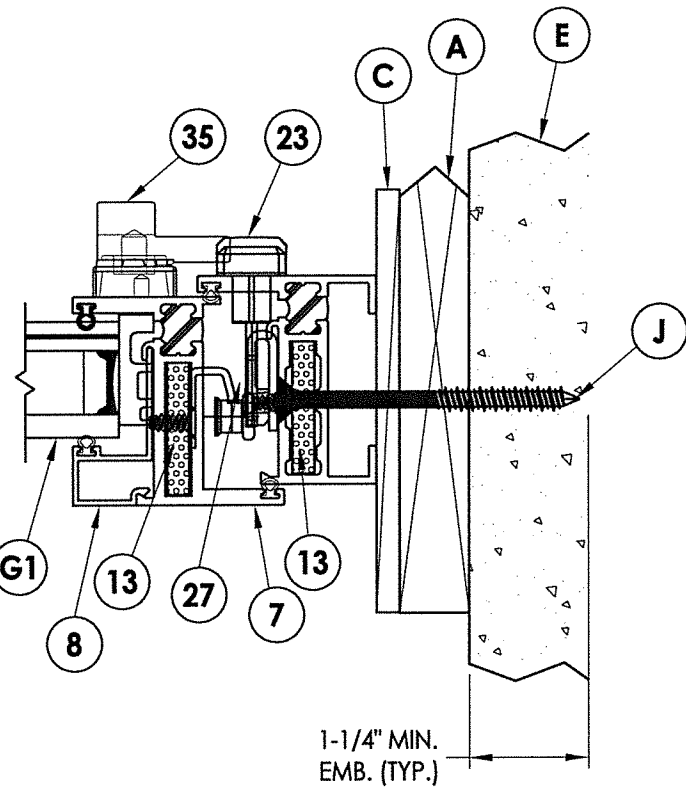

2 HORIZONTAL CROSS SECTION
4 Shown w/ 1X Sub buck option

NOTE:

1. Sheet Metal Screws must penetrate a min. of 3 threads through at least two (2) sheets of metal.

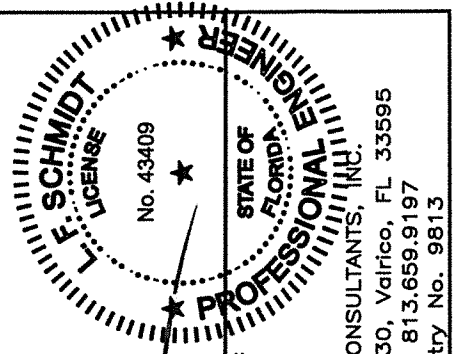

December 7, 2021
Documents Prepared By:
Lyndon F. Schmidt
P.E. No. 43409
RW
BUILDING CONSULTANTS, INC.
P.O. Box 230, Valrico, FL 33595
Phone No.: 813.659.9197
FBPE Registry No. 9813

PRODUCT:	FLEETWOOD WINDOWS & DOORS
PART OR ASSEMBLY:	HORIZONTAL & VERTICAL CROSS SECTIONS

NO.	DATE	BY	REVISIONS

DATE:	12/01/21
SCALE:	N.T.S.
DWG. BY:	LFS
CHK. BY:	RW
DRAWING NO.:	FL-14904.14
SHEET	4 OF 9

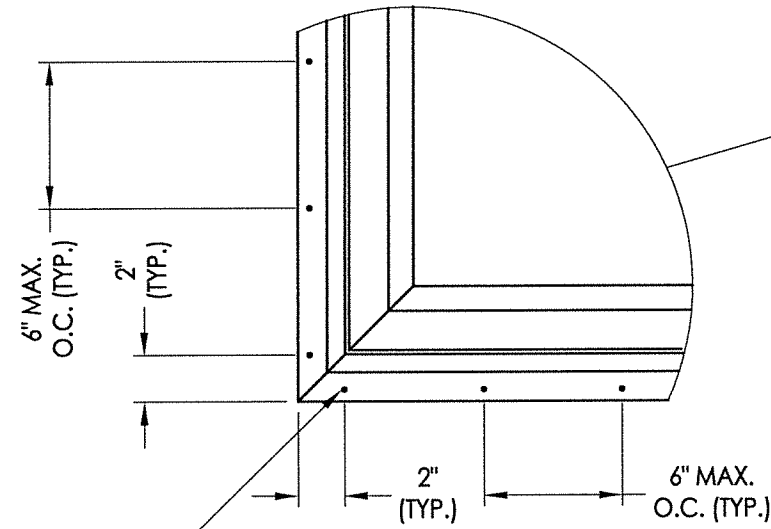

NAIL-FIN ANCHORING

WOOD BUCK/STUD: #8 PPH WOOD SCREW (Must penetrate a min. of 1-3/8" into wood substrate)
 STEEL STUD: #10 PPH SELF-DRILLING SMS (Must penetrate a min. of 3 threads through 0.033" min. thick steel)

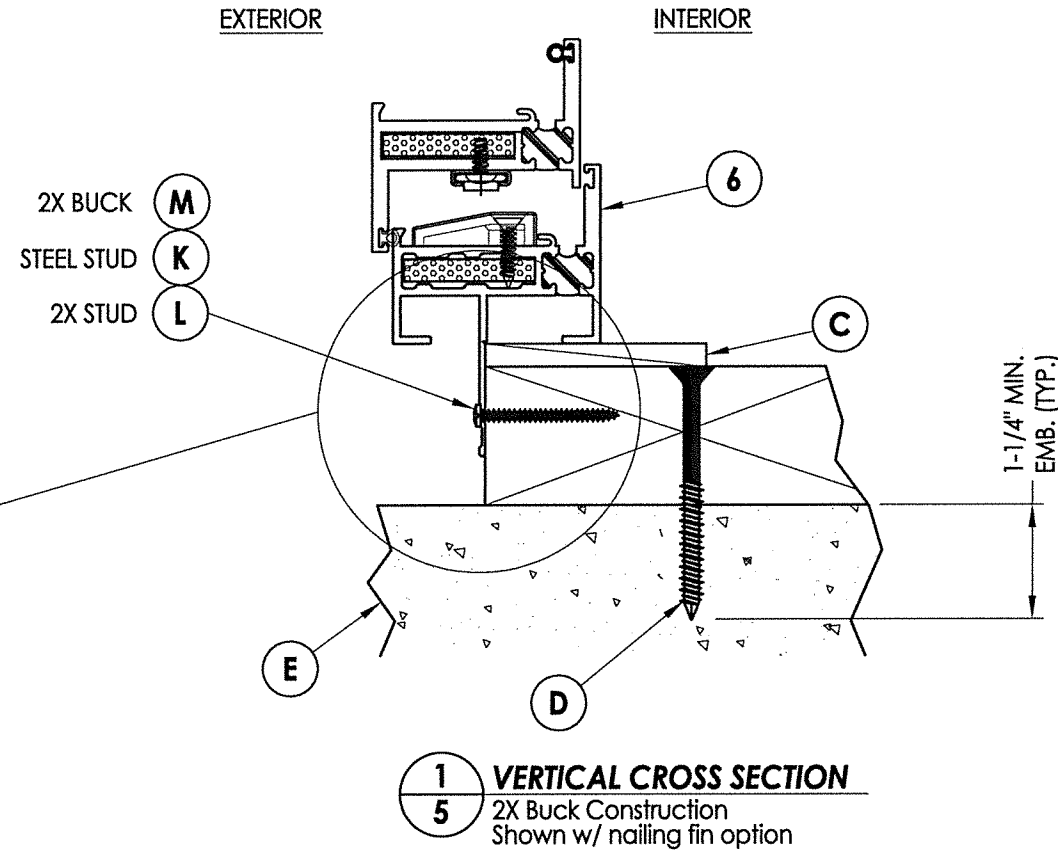

1 VERTICAL CROSS SECTION
5 2X Buck Construction
 Shown w/ nailing fin option

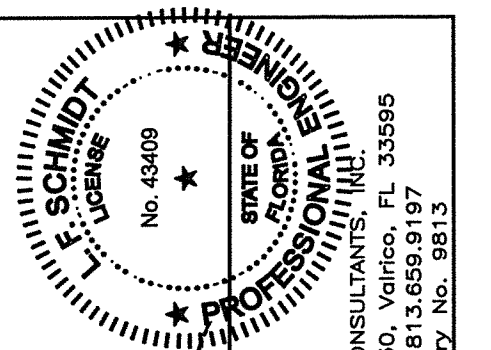

December 7, 2021
 Documents Prepared By:
 Lyndon F. Schmidt
 P.E. No. 43409
 R.W. BUILDING CONSULTANTS, INC.
 P.O. Box 230, Valrico, FL 33595
 Phone No.: 813.659.9197
 FBPE Registry No. 9813

PRODUCT:		FLEETWOOD WINDOWS & DOORS
PART OR ASSEMBLY:		VERTICAL CROSS SECTION
NO.	DATE	BY
REVISIONS		
DATE:	12/01/21	
SCALE:	N.T.S.	
DWG. BY:	LFS	
CHK. BY:	RW	
DRAWING NO.:	FL-14904.14	
SHEET	5	OF 9

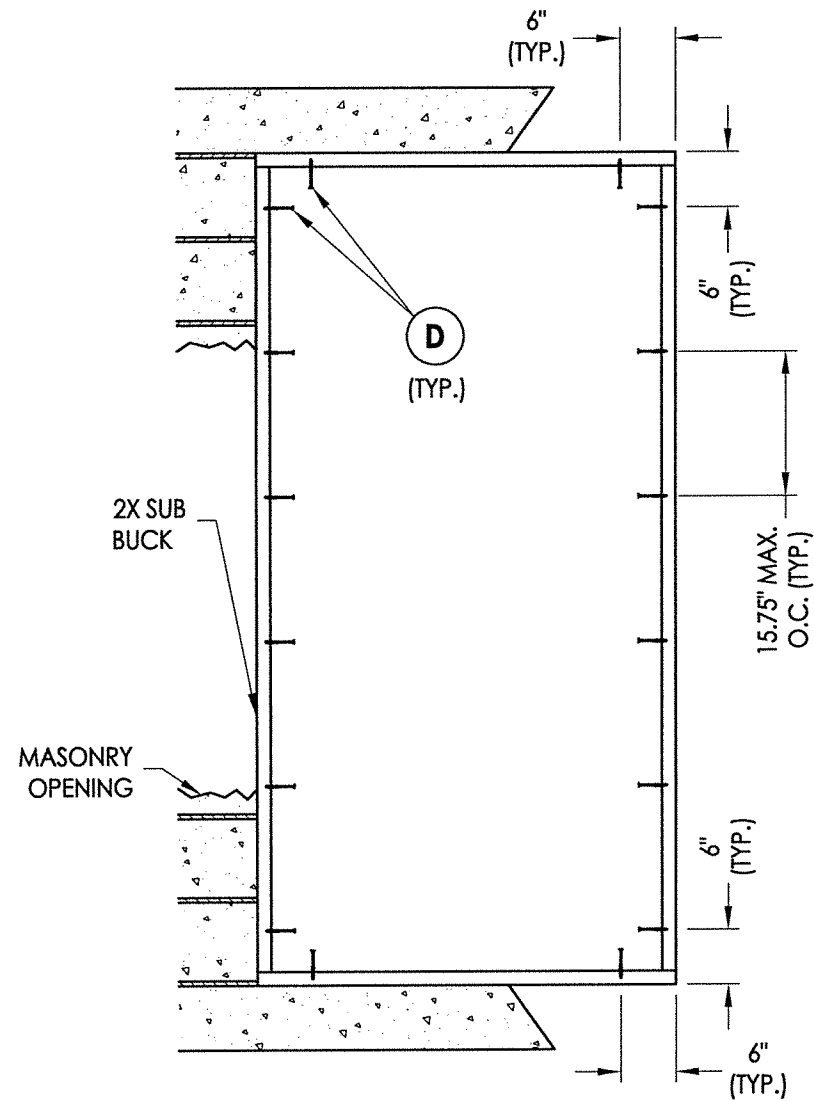

2X BUCK ANCHORING

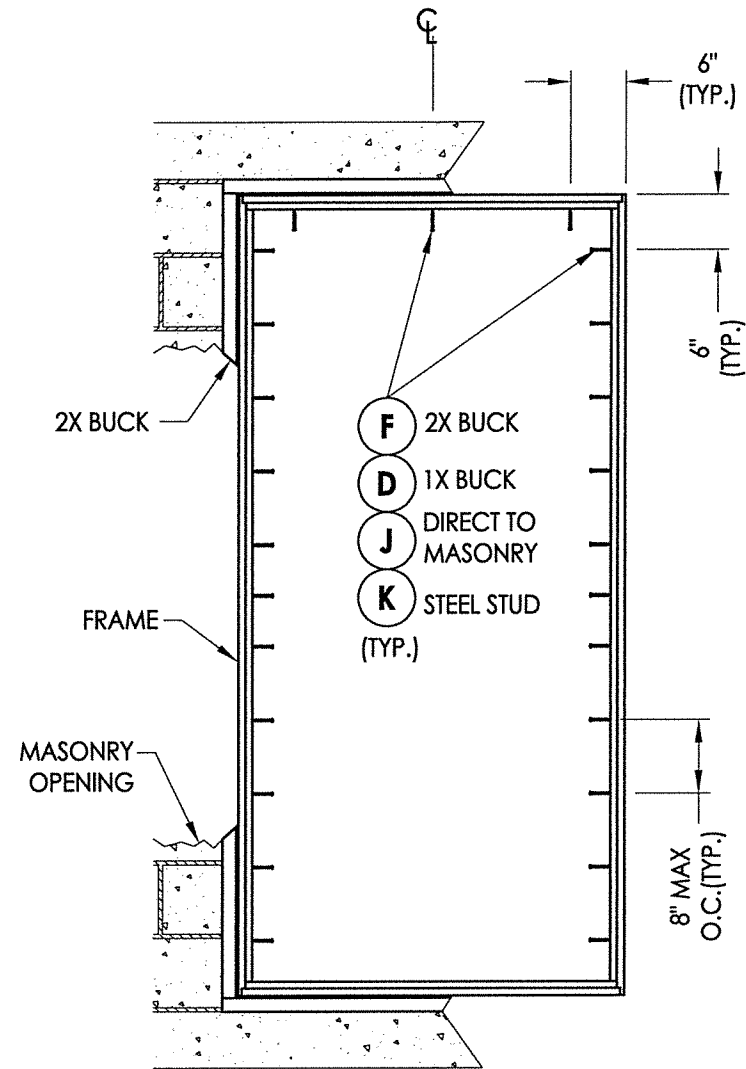

FRAME MOUNT ANCHORING

CONCRETE ANCHOR NOTES:

1. Concrete anchor locations at the corners may be adjusted to maintain the min. edge distance to mortar joints.
2. Concrete anchor locations noted as "MAX. ON CENTER" must be adjusted to maintain the min. edge distance to mortar joints, additional concrete anchors may be required to ensure the "MAX. ON CENTER" dimension are not exceeded.
3. Concrete anchor table:

ANCHOR TYPE	ANCHOR SIZE	MIN. EMBEDMENT	MIN. CLEARANCE TO MASONRY EDGE	MIN. CLEARANCE TO ADJACENT ANCHOR
ITW TAPCON®	1/4"	1-1/4"	2"	4"
DeWALT ULTRACON+®	1/4"	1-1/4"	1"	4"

WOOD SCREW INSTALLATION NOTES:

1. Maintain a minimum 5/8" edge distance, 1" end distance, & 1" o.c. spacing of wood screws to prevent the splitting of wood.

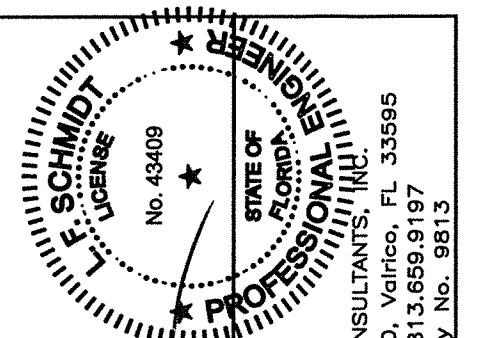

[Signature]

December 7, 2021

Documents Prepared By:
Lyndon F. Schmidt
P.E. No. 43409

R.W. BUILDING CONSULTANTS, INC.
P.O. Box 230, Valrico, FL 33595
Phone No.: 813.659.9197
FBPE Registry No. 9813

PRODUCT:
FLEETWOOD WINDOWS & DOORS

PART OR ASSEMBLY:
BUCK & FRAME ANCHORING

NO.	DATE	BY	REVISIONS

DATE: 12/01/21
SCALE: N.T.S.
DWG. BY: LFS
CHK. BY: RW
DRAWING NO.: FL-14904.14
SHEET 6 OF 9

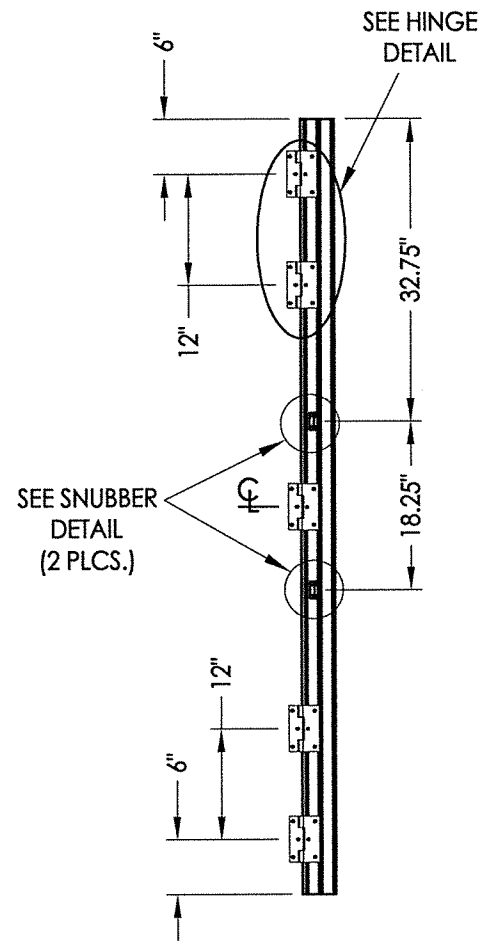

HINGE JAMB

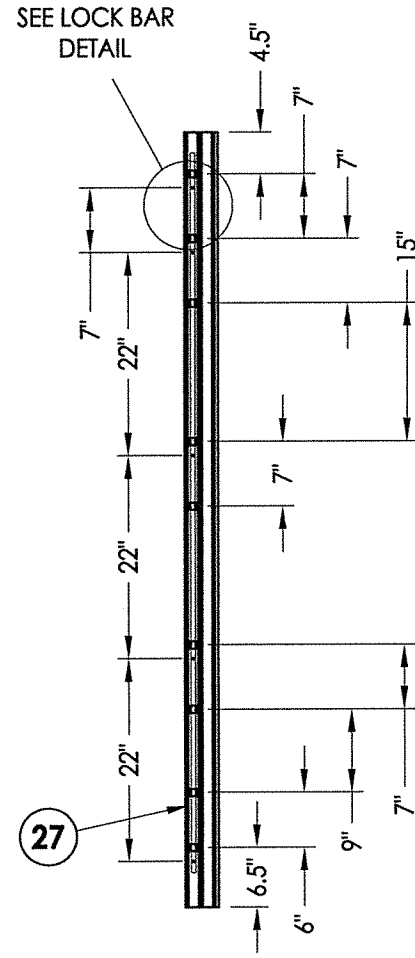

LOCK JAMB
LOCKING POINTS (5)

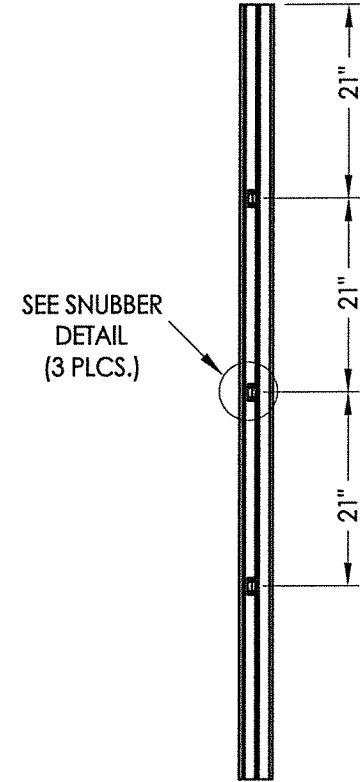

SNUBBERS JAMB

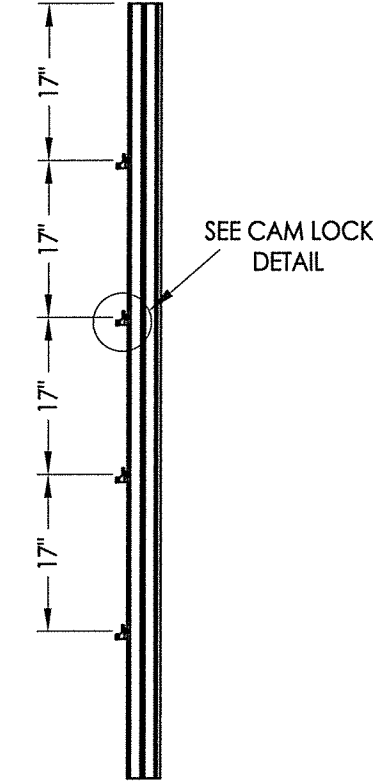

LOCK JAMB
CAM LOCKING POINTS (4)

BUTT HINGES w/ MULTIPOINT LOCKING BAR

4 POINT HINGE w/ CAM LOCKS

NOTE: Cam locks can be used in conjunction with the multipoint lock or in lieu of the multipoint lock.

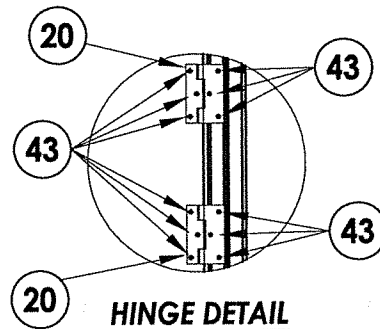

HINGE DETAIL

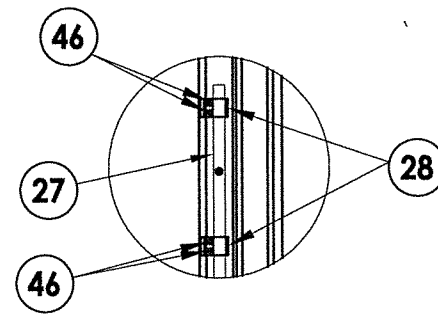

LOCK BAR DETAIL

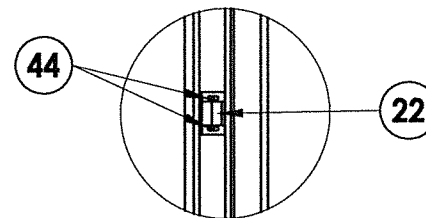

SNUBBER DETAIL

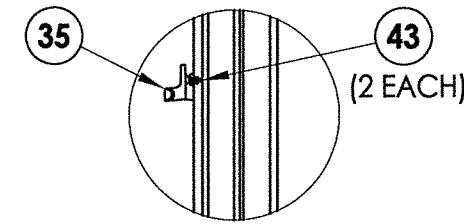

CAM LOCK DETAIL

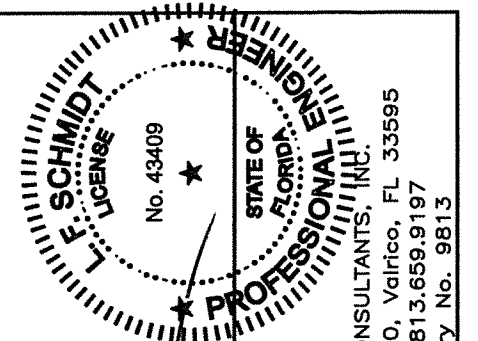

December 7, 2021
 Documents Prepared By:
 Lyndon F. Schmidt
 P.E. No. 43409
 R.W. BUILDING CONSULTANTS, INC.
 P.O. Box 230, Valrico, FL 33595
 Phone No.: 813.659.9197
 FBPE Registry No. 9813

PRODUCT:		FLEETWOOD WINDOWS & DOORS	
PART OR ASSEMBLY:		HARDWARE DETAILS	
NO.	DATE	BY	REVISIONS

DATE: 12/01/21
 SCALE: N.T.S.
 DWG. BY: LFS
 CHK. BY: RW
 DRAWING NO.: FL-14904.14
 SHEET 7 OF 9

BILL OF MATERIALS		
ITEM #	DESCRIPTION	MATERIAL
A	1X BUCK SG >= 0.55	WOOD
B	2X BUCK SG >= 0.55	WOOD
C	1/4" MAX. SHIM SPACE	-
D	1/4" X 2-3/4" DeWALT OR ITW PFH CONCRETE SCREW	STEEL
E	MASONRY - 3,000 PSI MIN. CONCRETE CONFORMING TO ACI 301 OR HOLLOW BLOCK CONFORMING TO ASTM C90	CONCRETE
F	#10 X 2-1/2" PPH WOOD SCREW (1-1/4" MIN. EMBEDMENT)	STEEL
J	1/4" X 3-1/4" DeWALT OR ITW PFH CONCRETE SCREW	STEEL
K	#10 PPH SELF-DRILLING SMS	STEEL
L	#8 PPH WS (1-3/8" MIN. EMBEDMENT)	STEEL
M	#8 X 1-1/2" PPH SMS (1-3/8" MIN. EMBEDMENT)	STEEL
X	STEEL STUD Min. Thk .033" (ASTM A653 GRADE 33 Fy=33 Ksi Min, Fu=45 Ksi Min)	STEEL
3	THERMAL BREAK ("LIQUID POLYURETHANE" by Azon USA, Inc.)	-
5	BLOCK FRAME (350-T)	6063-T6 ALUM
6	FIN BLOCK FRAME (350-T)	6063-T6 ALUM
7	ZEE BAR (PANEL)	6063-T6 ALUM
8	GLASS STOP (1-1/4")	6063-T6 ALUM
10	GLASS STOP (9/16")	6063-T6 ALUM
13	CORNER KEY	6063-T6 ALUM
20	SS. BUTT HINGE	SS
21	4 BAR HINGE	SS
22	SNUBBER-COMMERCIAL PULL-IN BLOCK	SS
23	MULTIPOINT LOCK HANDLE	SS
27	5 POINTS LOCKING BAR (TRUTH)	SS
28	TIE BAR GUIDE (TRUTH)	-
29	KEEPER (TRUTH)	SS
30	CASEMENT ROTOR GEAR (TRUTH)	SS
35	CAM HANDLE / STRIKE PLATE	SS
36	CASEMENT SS. TRACK (TRUTH)	SS
40	#10 X 1" PPH SMS	STEEL
43	SCREW NO 10, UFHP, .5"	STEEL
44	SCREW NO 8, PHP, .50"	STEEL
46	SCREW NO 8, FHP, .750"	STEEL
50	BULB VINYL (EPDM 70 DUROMETER) - TREMCO	-
51	MINI BULB VINYL (EPDM 70 DUROMETER) - TREMCO	-
55	SETTING BLOCK	-
57	PIVOT SHIM	-

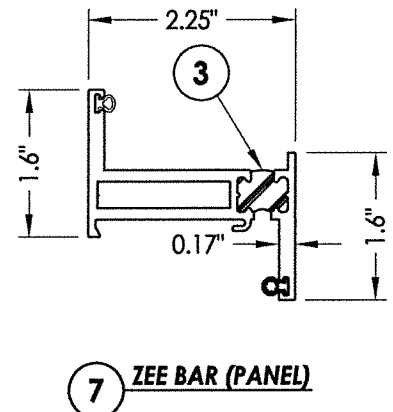
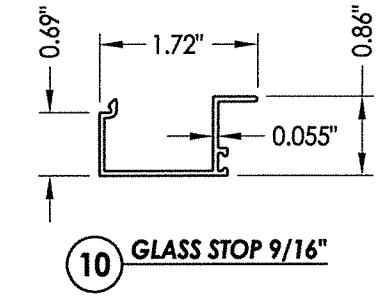
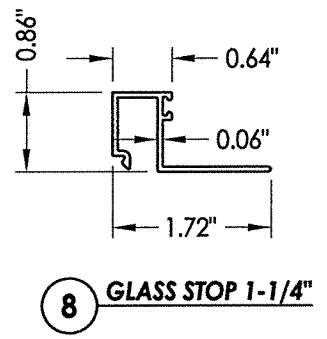
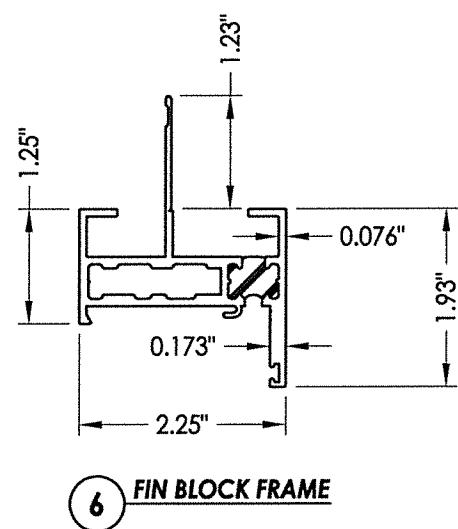
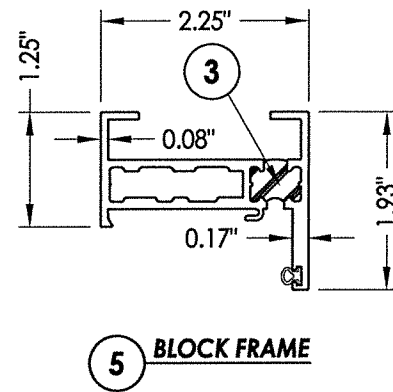

Lyndon F. Schmidt
P.E. No. 43409

December 7, 2021
Documents Prepared By:
Lyndon F. Schmidt
P.E. No. 43409

R.W. BUILDING CONSULTANTS, INC.
P.O. Box 230, Valrico, FL 33595
Phone No.: 813.659.9197
FBPE Registry No. 9813

PRODUCT:		FLEETWOOD WINDOWS & DOORS	
PART OR ASSEMBLY:		BILL OF MATERIALS AND COMPONENTS	
NO.	DATE	BY	REVISIONS
DATE: 12/01/21		SCALE: N.T.S.	
DWG. BY: LFS		CHK. BY: RW	
DRAWING NO.: FL-14904.14		SHEET 9 OF 9	