

**MIAMI-DADE COUNTY
PERFORMANCE TEST REPORT**

Rendered to:

FLEETWOOD WINDOWS & DOORS

**SERIES/MODEL: Norwood 3070HI OXIXO
PRODUCT TYPE: 135° Sliding Glass Pocket Door**

This report contains in its entirety:

**Cover Page: 1 page
Report Body: 10 pages
Sketches: 2 pages
Drawings: 5 pages**

**Report No.: 78674.01-301-18
Test Dates: 01/08/08
Through: 01/16/08
Report Date: 02/25/08
Expiration Date: 01/16/18
Miami-Dade County Notification No.: ATI CA 07011**

MIAMI-DADE COUNTY PERFORMANCE TEST REPORT

Rendered to:

FLEETWOOD WINDOWS & DOORS
395 Smitty Way
Corona, California 92879

Report No.: 78674.01-301-18

Test Dates: 01/08/08

Through: 01/16/08

Report Date: 02/25/08

Expiration Date: 01/16/18

Miami-Dade County Notification No.: ATI CA 07011

Project Summary: Architectural Testing, Inc. was contracted by Fleetwood Windows & Doors to perform testing per Florida Building Code, Test Protocols for High Velocity Hurricane Zone, Protocols TAS 201-94, TAS 202-94 (structural loads only) and TAS 203-94 on a Series/Model Norwood 3070HI configuration OXIXO, 135° sliding glass pocket door. The sample tested met the performance requirements set forth in the protocols for a +55.0 / -53.3 psf *Design Pressure* rating. Test specimen description and results are reported herein. The samples were provided by the client

Test Procedures: The test specimen was evaluated in accordance with the following:

TAS 201-94, *Impact Test Procedures.*

TAS 202-94, *Criteria for Testing Impact and Non Impact Resistant Building Envelope Components Using Uniform Static Air Pressure Loading.*

TAS 203-94, *Criteria for Testing Products Subject to Cyclic Wind Pressure Loading.*

Drawing Reference: The test specimen drawings have been reviewed and verified by Architectural Testing and are representative of the samples tested.

Test Specimen Description:

Series/Model: Norwood 3070HI

Configuration: OXIXO

Product Type: 135° Sliding Glass Pocket Door

Test Specimen Description: (Continued)

Overall Size: 9' 9-3/4" wide / 9' 8-7/16" wide by 9' 7" high

Fixed Panel Size: Two panels 4' 10-5/8" wide by 9' 5-3/16" high

Active Locking Panel Size: 5' 0-3/4" wide by 9' 5-3/16" high

Active Keeper Panel Size: 5' 2" wide by 9' 5-3/16" high

Finish: All aluminum was painted white.

Glazing Details: All panels were glazed with a nominal 9/16" thick laminated glass consisting of 0.220" heat-strengthened glass, 0.075" StormGlass™ and 0.220" heat-strengthened glass manufactured by Oldcastle Glass®. All panels were channel glazed using Dow Corning 995 sealant and 4' long setting blocks. The glass bite was 9/16".

Weatherstripping:

<u>Description</u>	<u>Quantity</u>	<u>Location</u>
Amesbury center-fin weather seal 0.270" high polypropylene pile	8 Rows	Each sill track leg. (Weatherstripping applied for the length of panel travel)
Amesbury center-fin weather seal 0.290" high polypropylene pile	4 Rows	The head. (Weatherstripping applied for the length of panel travel)
Amesbury center-fin weather seal 0.230" high polypropylene pile	2 Rows	Female yoke
Amesbury heavy density weather seal 0.300" high polypropylene pile	1 Row	Each panel interlock stile
6" long vinyl weatherstrip holder with Q-Lon vinyl wrapped foam weather seal 0.300" high	1 Piece	The top and bottom of each panel interlock stile
Aluminum clip with brush seal air barrier	6	The bottom end of each panel interlock stile and the top end of the pocket panel butt stile. Each air barrier was secured with two #6 x 1/2" long TEKS screws.

Test Specimen Description: (Continued)

Weatherstripping: (Continued)

<u>Description</u>	<u>Quantity</u>	<u>Location</u>
Amesbury heavy density weather seal 0.290" high polypropylene pile	2 Rows	Each jamb.

Frame Construction: All frame members consisted of extruded aluminum extrusions. An aluminum sill pan with 0.062" thick walls was employed. The vertical leg of the sill pan measured 2.00" high and was 0.135" thick. The head and sill members were cut at midspan to create a 135° angle. The door jambs were coped and were attached to the head and sill with two #10 x 3/4" Phillips pan head sheet metal screws at each location. Aluminum channel fillers were employed at the all frame members. Aluminum sill channel fillers were employed between the fixed panel interlock stiles.

Panel Construction: All panels were constructed from extruded aluminum alloy. The corners were coped, butted and attached using a single #10 x 2" Phillips oval head sheet metal screw per corner. A steel yoke adapter was attached to the active panel keeper stile with nine #8 x 1" Phillips pan head sheet metal TEKS screws spaced evenly. A 135° aluminum yoke snapped onto the yoke adapter and was attached to the yoke adapter with ten #8 x 3/4" Phillips flat head sheet metal screws on each face of the yoke (30 screws total). A male yoke was attached to the 135° yoke with ten #10 x 3/4" Phillips pan head sheet metal screws spaced evenly. The female yoke was attached to the active panel lock stile with seven #10 x 3/4" Phillips pan head sheet metal screws spaced evenly. Each fixed panel was attached to the fixed panel jamb with four #8 x 1/2" Phillips flat head sheet metal screws at 39" from each end, two at the interior and two at the exterior. The top of interlock stile and lead stiles were filled with spray foam.

Hardware:

<u>Description</u>	<u>Quantity</u>	<u>Location</u>
Mammoth adjustable metal double roller assembly (wheel diameter 3")	4	Two per active panel bottom rail.
Fleetwood two point locking system (Part #117-101) and pull handle set	1	Locking points located 32-1/2" and 68-1/2" from the top of the lock stile with the strike mortised into the keeper stile yoke at lock locations.

Test Specimen Description: (Continued)

Drainage: The underside of the sill was saw cut 1" wide by leg height (approximately 0.157") by the full depth of the sill to allow drainage into the sill pan. The cuts were located approximately 12" from each end of the sill and 24" on center.

Reinforcement: No reinforcement was utilized.

Installation: Screws and method of attachment:

Header: (54) #10 x 2" Phillips pan head screws spaced 5" from each end and then 14-16" on center. Two fasteners were located at each location, one per track.

Sill: (54) #10 x 2" Phillips pan head screws spaced 5" from each end and then 14-16" on center. Three fasteners were located at each location, one per track.

Fixed Panel Jamb: (20) #10 x 2" Phillips flat head sheet metal screws 4" from each end spaced evenly (two per location, one per track).

Fixed Panels: Four #8 x 3/4" Phillips pan head sheet metal screws attaching the fixed panel jamb stile to the jamb 39" from each end; two at the interior and two at the exterior.

Test Results: The following results have been recorded:

Protocol TAS 202-94, *Static Air Pressure Tests* (Structural Loads only)

Test Unit #1

Design Pressure: +55.0 / -53.3 psf

Title of Test	Results		
	Indicator Readings (inch)		
	#1	#2	#3
Structural Loads			
50% of Test Pressure (+41.25psf)			
Maximum Deflection	0.30	0.79	0.23
Permanent Set	0.10	0.17	0.10
Design Pressure (+55psf)			
Maximum Deflection	0.31	0.92	0.17
Permanent Set	0.00	0.04	0.04
50% of Test Pressure (-45psf)			
Maximum Deflection	0.38	1.55	1.47
Permanent Set	0.15	0.72	1.29
Design Pressure (-60 psf)			
Maximum Deflection	0.40	1.46	0.75
Permanent Set	0.09	0.45	0.55
Test Pressure (+82.5psf)			
Maximum Deflection	0.69	1.71	0.21
Permanent Set	0.37	0.30	0.11
Test Pressure (-80.0psf)			
Maximum Deflection	0.45	1.13	0.32
Permanent Set	0.21	0.14	0.07

Note: See Architectural Testing Sketch #1 for indicator locations.

Test Results: (Continued)

Protocol TAS 201-94, *Impact Test Procedures*

Missile Weight: 9 lbs

Muzzle Distance from Test Specimen: 17 ft.

Test Unit #1

Impact #1: Missile Velocity: 49.5 fps

Impact Area: Center of meeting stile

Observations: No penetration

Results: Pass

Impact #2: Missile Velocity: 49.2 fps

Impact Area: Center of second panel from right

Observations: No penetration

Results: Pass

Impact #3: Missile Velocity: 49.0 fps

Impact Area: Bottom left corner of second panel from right

Observations: No penetration

Results: Pass

Note: Refer to Architectural Testing Sketch #2 for impact locations.

Test Results: (Continued)

Protocol TAS 203-94, Cyclic Wind Pressure Loading

Test Unit #1

Design Pressure: +55.0 psf / -60.0 psf

POSITIVE PRESSURE

Pressure Range (psf)	Number of Cycles	Average Cycle Time (sec.)	Maximum Deflection at Indicator (inch)		
			#1	#2	#3
11.0 to 27.5	3500	3.88	0.04	0.71	0.21
0 to 33.0	300	7.11	0.06	0.88	0.25
27.5 to 44.0	600	5.49	0.14	1.10	0.30
16.5 to 55.0	100	8.99	0.19	1.25	0.35
			Permanent Set (inch)		
			0.11	0.20	0.09

NEGATIVE PRESSURE

Pressure Range (psf)	Number of Cycles	Average Cycle Time (sec.)	Maximum Deflection at Indicator (inch)		
			#1	#2	#3
18.0 to 60.0	50	9.49	0.47	1.66	0.65
30.0 to 48.0	1050	4.45	0.35	1.42	0.55
0 to 36.0	50	8.42	0.30	1.33	0.41
12.0 to 30.0	3350	3.99	0.20	1.01	0.37
			Permanent Set (inch)		
			0.10	0.21	0.15

Result: Pass

Note: Refer to Architectural Testing Sketch #1 for indicator locations.

Test Equipment:

Cannon: Steel pipe barrel utilizing compressed air to propel the missile

Missile: 2x4 Southern Pine

Timing Device: Electronic Beam Type

Cycling Mechanism: Computer controlled centrifugal blower with electronic pressure measuring device

Deflection Measuring Device: Linear transducers

Laboratory Compliance Statements: The following are provided as required by the protocols for the testing reported herein.

Upon completion of testing, specimens tested for TAS 201-94 met the requirements of Section 1626 of the Florida Building Code, Building (2004).

Upon completion of testing, specimens tested for TAS 202-94 met the requirements of Section 1620 of the Florida Building Code, Building (2004).

Upon completion of testing, specimens tested for TAS 203-94 met the requirements of Section 1626 of the Florida Building Code, Building (2004).

Tape and film were used to seal against air leakage during structural testing. In our opinion, the tape and film did not influence the results of the test.

Testing was conducted at the Architectural Testing, Inc. laboratory located in Fresno, California.

List of Official Observers:

<u>Name</u>	<u>Company</u>
Nathan Baker	Fleetwood Windows & Doors
Leaton Kirk	Architectural Testing, Inc.
Dennis Janzen	Architectural Testing, Inc.
Jeffrey T. Kaminski, P.E.	Architectural Testing, Inc
Tyler Westerling, P.E.	Architectural Testing, Inc.

Detailed drawings, data sheets, representative samples of test specimens, a copy of this report, or other pertinent project documentation will be retained by Architectural Testing, Inc. for a period of ten years from the original test date. At the end of this retention period, such materials shall be discarded without notice and the service life of this report will expire.

Results obtained are tested values and were secured by using the designated test methods. This report does not constitute certification of this product nor an opinion or endorsement by this laboratory. It is the exclusive property of the client so named herein and relates only to the specimen tested. This report may not be reproduced, except in full, without the written approval of Architectural Testing, Inc.

For ARCHITECTURAL TESTING, INC.

Tyler Westerling, P.E.
Project Engineer

Jeffrey T. Kaminski, P.E.
Senior Project Engineer

TW:kb/cmd

Attachments (pages): This report is complete only when all attachments listed are included.

Appendix-A: Sketches (2)

Appendix-B: Drawings (5)

Revision Log

<u>Rev. #</u>	<u>Date</u>	<u>Page(s)</u>	<u>Revision(s)</u>
0	02/25/08	N/A	Original report issue

Appendix A

Sketches

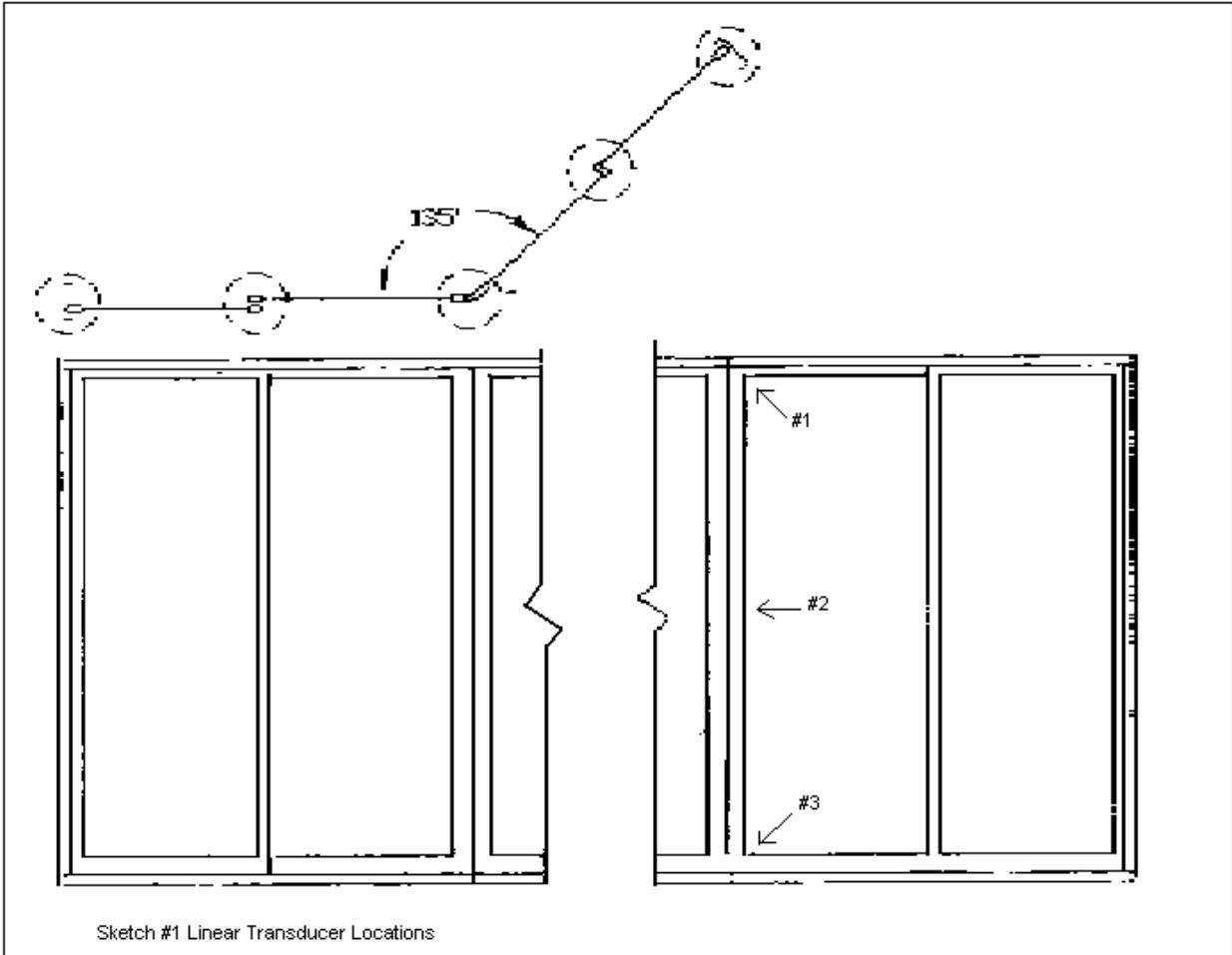

Sketch #1
Linear Transducer Locations

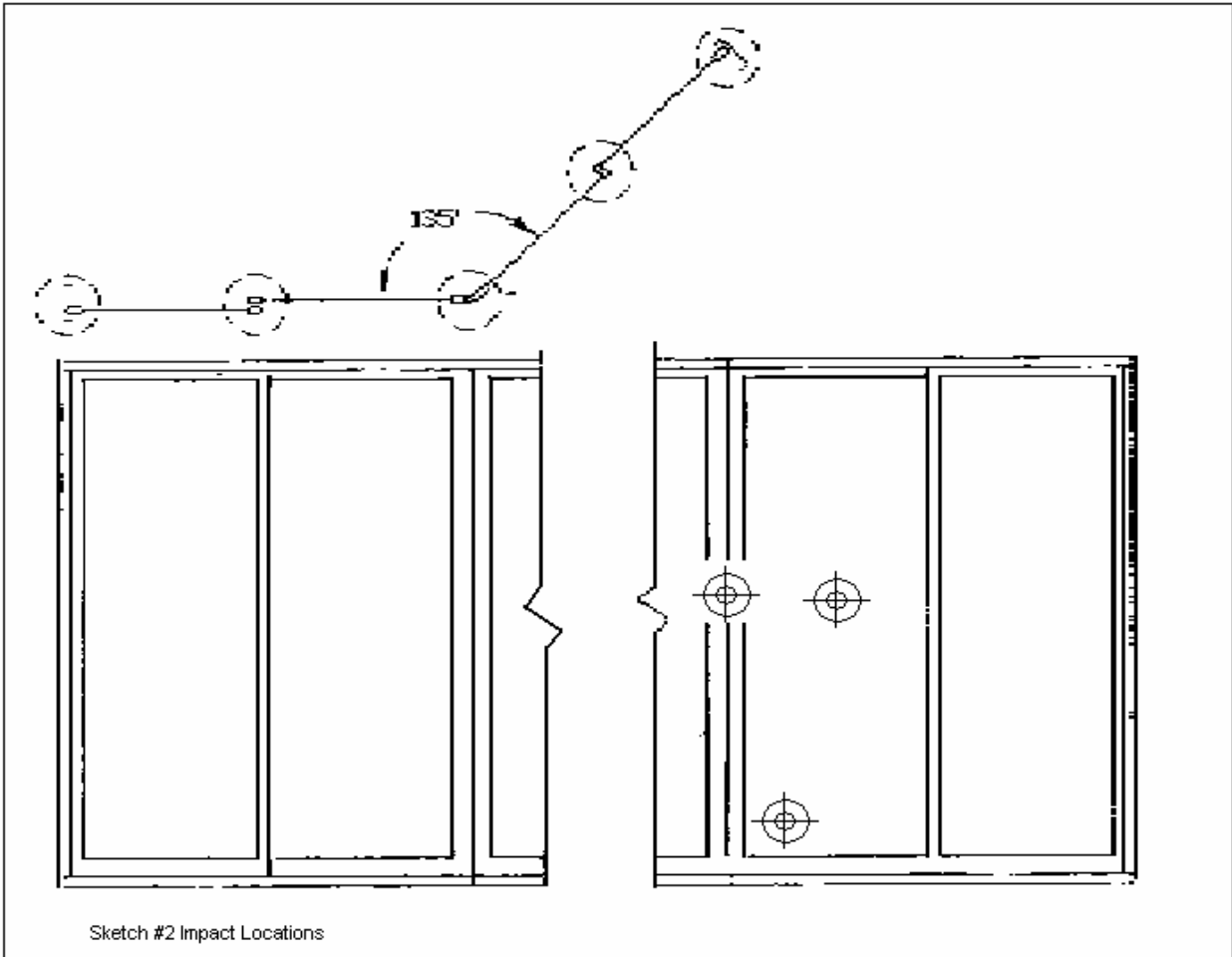

**Sketch #2
Impact Locations**

Appendix B

Drawings

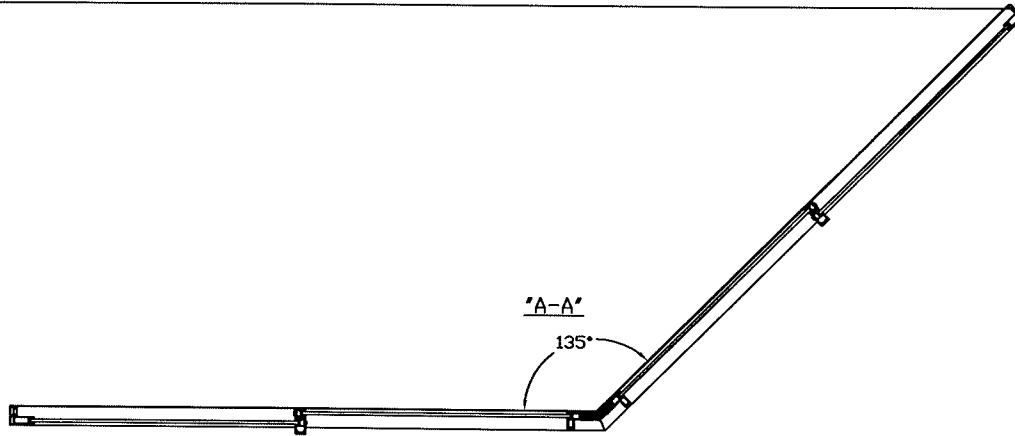

Architectural Testing, Inc
 Test sample complies with these details
 Deviations are noted

7 8 6 7 4

FEB 0 4 2008

Report#

Tech *W*

Date

SEE CORNER CONSTRUCTION
 REQUIREMENTS ON SHEET 1

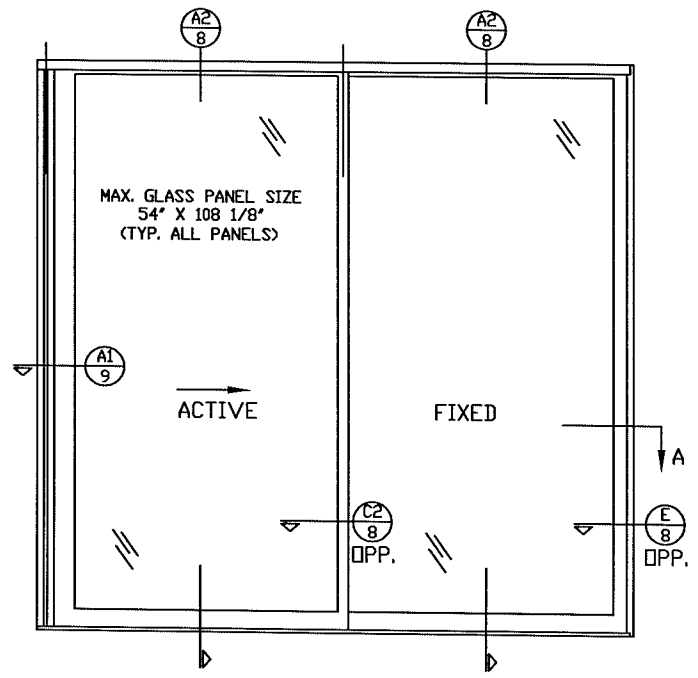
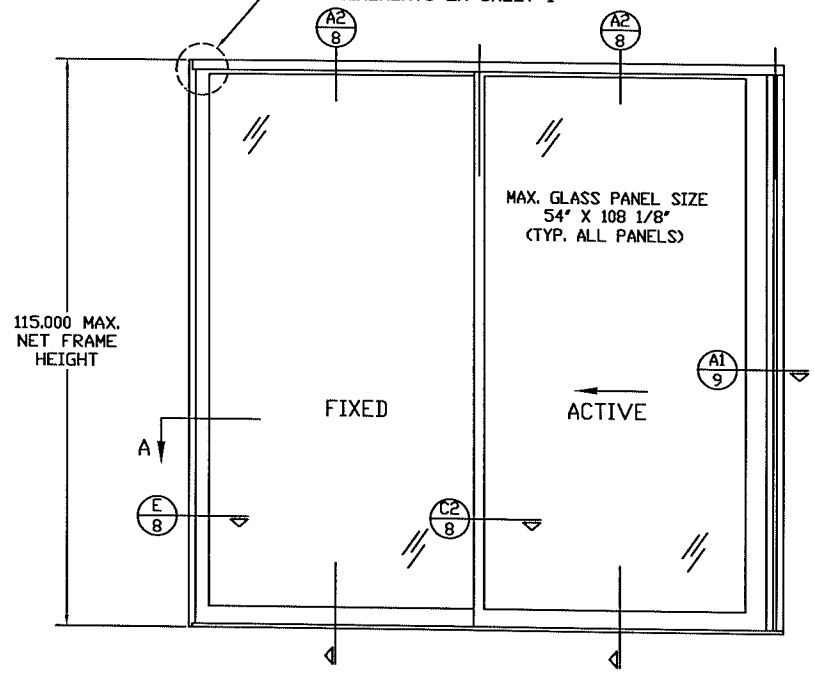

DRAWN BY: WDE	DATE: 01/04/08
SCALE: 1/24	REV:
CONFIGURATION: 135° 0XIX0	

TITLE:
 NORWOOD 3070HI
 2008 CERTIFICATION
 SPECIMEN 4A/4B

	FLEETWOOD WINDOWS & DOORS FleetwoodUSA.com	
	DRAWING NUMBER: CERT-DADE08-S4	SHEET: 4 OF 10



Architectural Testing, Inc.
Test sample complies with these details.
Deviations are noted.

78674

FEB 04 2008

Report#

Test TV

Date

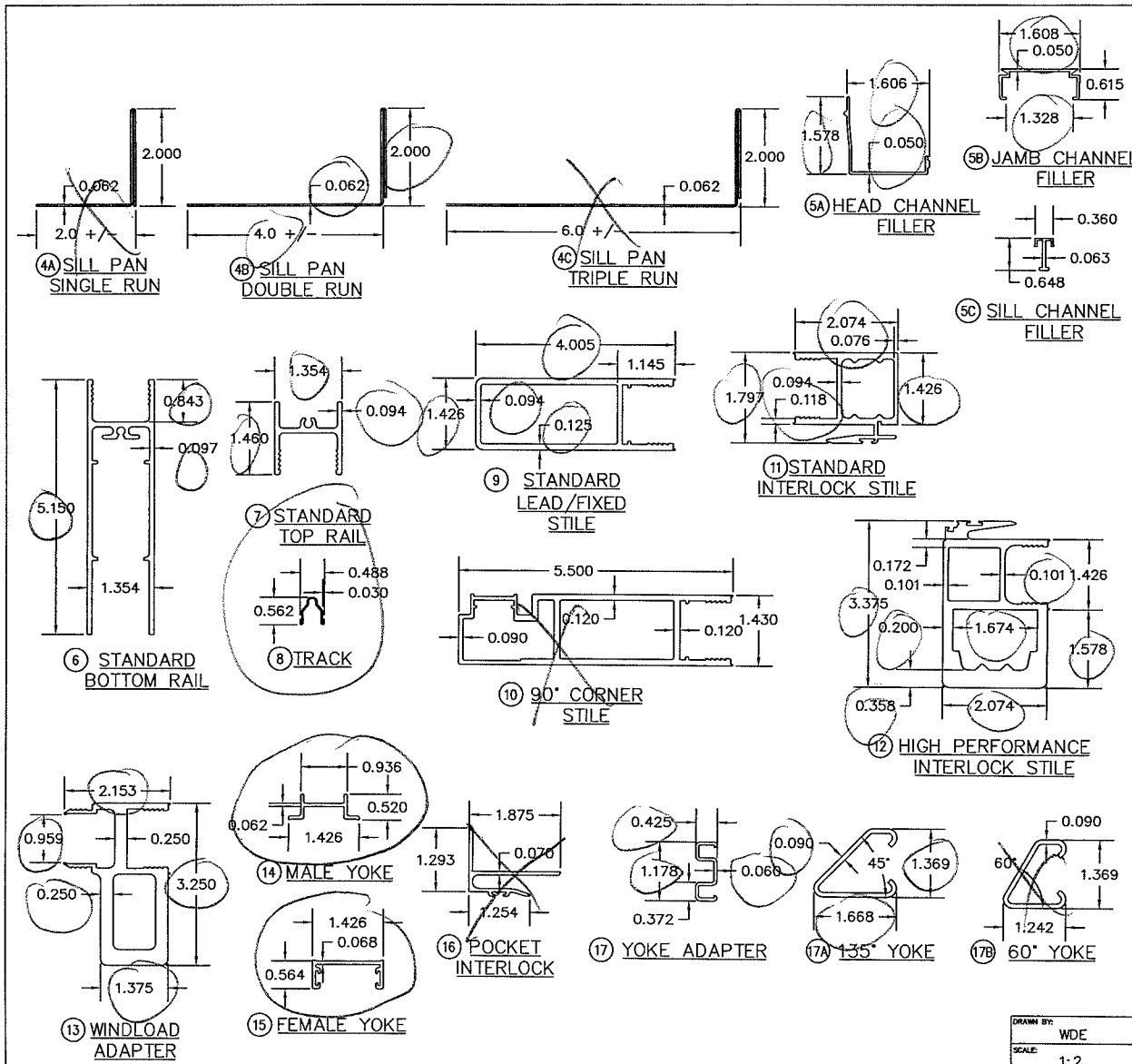

ITEM #	PART	ITEM DESCRIPTION	MANUFACTURER/NOTES
PARTS			
1A	3046	HEAD TRACK (1 RUN)	6063-T6 ALUMINUM
1B	3702	HEAD TRACK (2 RUNS)	6063-T6 ALUMINUM
1C	3703	HEAD TRACK (3 RUNS)	6063-T6 ALUMINUM
2A	3741	SILL TRACK (1 RUN)	6063-T6 ALUMINUM
2B	3742	SILL TRACK (2 RUNS)	6063-T6 ALUMINUM
2C	3743	SILL TRACK (3 RUNS)	6063-T6 ALUMINUM
3A	3048	JAMB TRACK (1 RUN)	6063-T6 ALUMINUM
3B	3712	JAMB TRACK (2 RUNS)	6063-T6 ALUMINUM
3C	3713	JAMB TRACK (3 RUNS)	6063-T6 ALUMINUM
4A	3720	SILL PAN (SINGLE RUN)	6063-T6 ALUMINUM
4C	3720	SILL PAN (TRIPLE RUN)	6063-T6 ALUMINUM
5A	3011	HEAD CHANNEL FILLER	6063-T5 ALUMINUM
5B	3747	SILL CHANNEL FILLER	6063-T5 ALUMINUM
5C	3750	JAMB CHANNEL FILLER	6063-T5 ALUMINUM
6	3004	STANDARD TOP RAIL	6063-T5 ALUMINUM
7	3709	STANDARD BOTTOM RAIL	6063-T6 ALUMINUM
8	M622	TRACK	STAINLESS STEEL
9	3767	STANDARD LEAD/FIXED STILE	6063-T5 ALUMINUM
10	3750	90° CORNER LOCK STILE	6063-T6 ALUMINUM
11	3006	STANDARD INTERLOCK STILE	6063-T6 ALUMINUM
12	3034	HIGH PERFORMANCE INTERLOCK STILE	6063-T6 ALUMINUM
13	3715	WINDLOAD ADAPTER	6063-T5 ALUMINUM
14	3039	MALE YOKE	6063-T6 ALUMINUM
15	3040	FEMALE YOKE	6063-T5 ALUMINUM
16	3730	POCKET INTERLOCKER	6063-T6 ALUMINUM
17	FW1037	YOKE ADAPTER	6063-T6 ALUMINUM
18A	FW1036	135° YOKE	6063-T6 ALUMINUM
18B	FW1036	60° YOKE	6063-T6 ALUMINUM
SEALS & SEALANTS			
20	-	LARGE MOHAIR	AMESBURY 13330-270R
21	-	FIN SEAL	AMESBURY 43629-270R
22	-	SEALANT	DOW CORNING 995
23	FW1036	PANEL BUMPER	
24	U-5212	Q-LON SEAL	SCHLAGE
HARDWARE			
30	117-101	HANDLE SET W/ LATCH	FLEETWOOD
31	117-106	HANDLE SET	FLEETWOOD
32	1059-1	STRIKE PLATE ASSY.(JAMB)	FLEETWOOD
33	3764	STRIKE PLATE(MALE YOKE)	FLEETWOOD
33	3765	STRIKE PLATE BACKUP(MALE YOKE)	FLEETWOOD
34	FW-1120	YOKE ADAPTER BACKUP PLATE	FLEETWOOD
35	FW-1120	MALE YOKE BACKUP PLATE	FLEETWOOD
36	FW-1042	MAMMOTH ROLLER ASSEMBLY	FLEETWOOD
37	AN7839	AIR BARRIER	PEMCO
38	AN7839-L	AIR BARRIER	PEMCO
MISCELLANEOUS			
40	-	4" LONG SETTING BLOCK	AS REQ'D
41	R10882	PVC M/S TRACK CONNECTOR	RYKO
42	3762	PANEL SETTING BLOCK	6063-T6 ALUMINUM
43	-	NO.8 X 1/2" PHND SMS	STAINLESS STEEL
44	-	NO.8 X 1/2" SMS	STAINLESS STEEL
45	-	#8 TEK X 3/8"	STAINLESS STEEL

DRAWN BY: WDE
SCALE: 1:2
CONFIGURATION: SECTION DETAILS

DATE: 01/04/08
REV:

TITLE: NORWOOD 3070HI '08 CERTIFICATION

FLEETWOOD
WINDOWS & DOORS
FleetwoodUSA.com

DRAWING NUMBER: CFRT-DADFOR-S10
SHEET: 10 OF 10



Architectural Testing, Inc.
 Test sample complies with these details.
 Revisions are noted.

78674

FEB 04 2008

Report#

Date

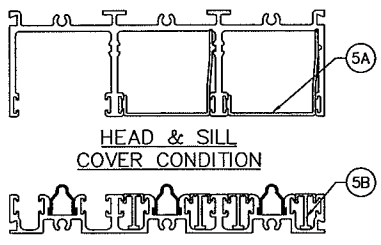

HEAD & SILL
COVER CONDITION

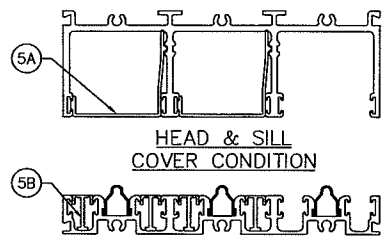

HEAD & SILL
COVER CONDITION

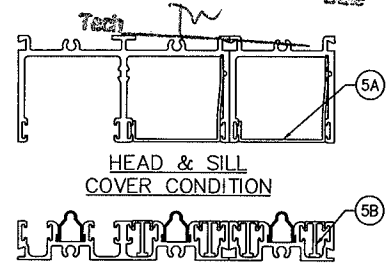

HEAD & SILL
COVER CONDITION

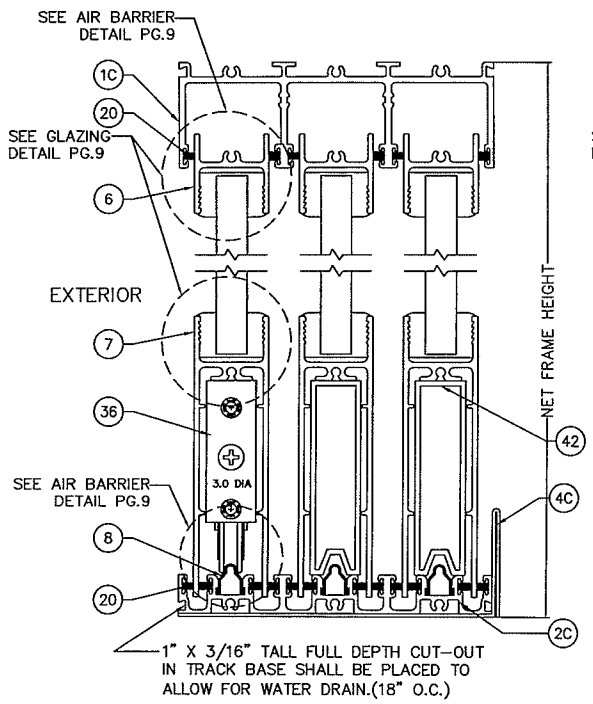

A1 SECTION
7 SCALE: 1/2 FULL

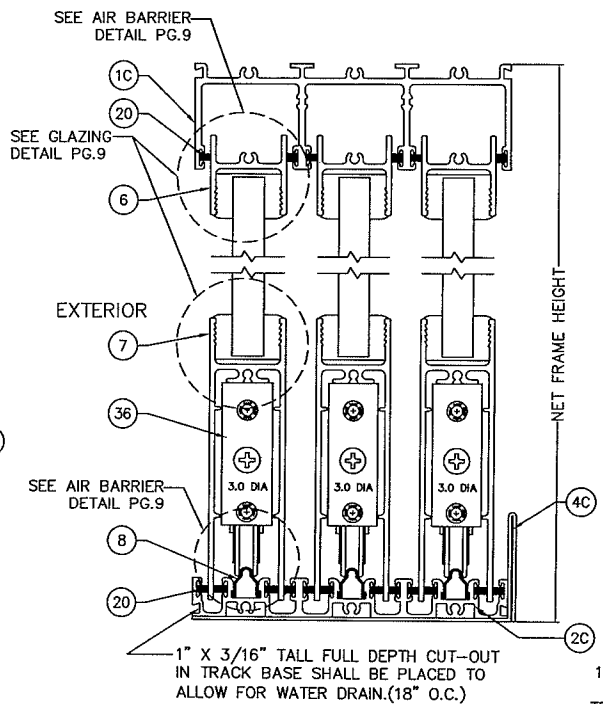

A2 SECTION
7 SCALE: 1/2 FULL

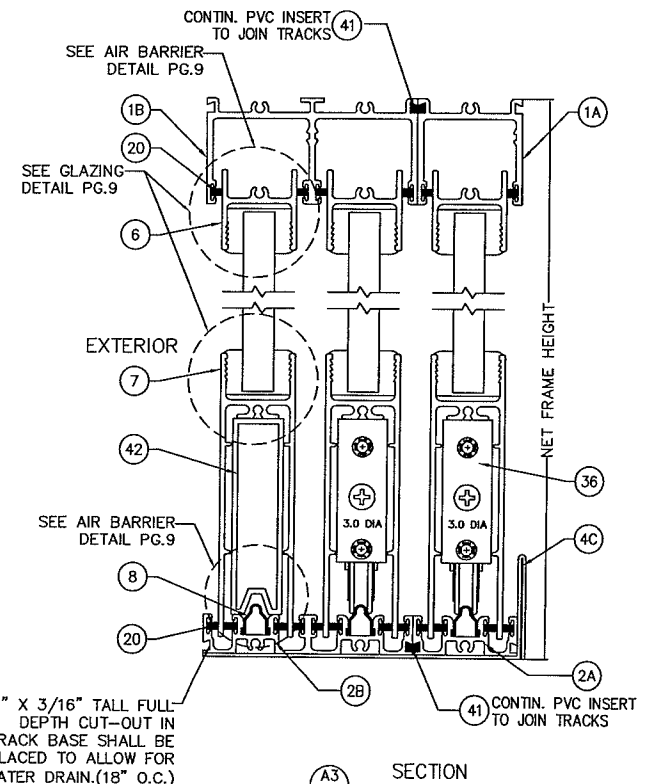

A3 SECTION
7 SCALE: 1/2 FULL

DRAWN BY:	DATE:	TITLE:
WDE	01/04/08	
SCALE:	REV:	
1:2		
CONFIGURATION:		
SECTION DETAILS		

NORWOOD 3070HI
 '08 CERTIFICATION

FLEETWOOD
 WINDOWS & DOORS
 FleetwoodUSA.com

DRAWING NUMBER: SEPT-DAD08-110 SHEET: 7 OF 10



Architectural Testing, Inc
 Test sample complies with these details
 Deviations are noted

7 8 6 7 4

FEB 0 4 2008

Report#

Date

Techn *rw*

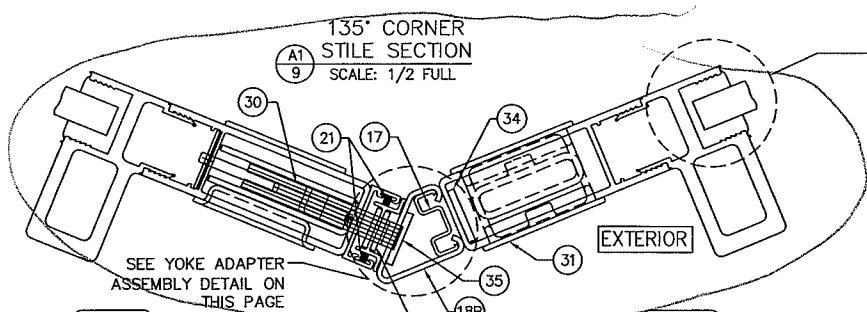

SEE GLAZING DETAIL ON THIS PAGE

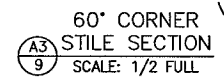

AIR BARRIER DETAIL (TYP.) ALL PANELS

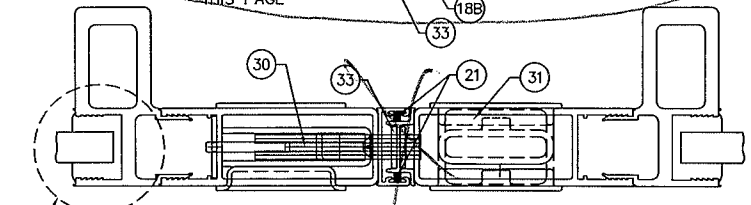
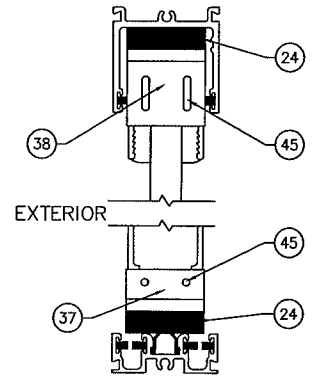

SEE GLAZING DETAIL ON THIS PAGE

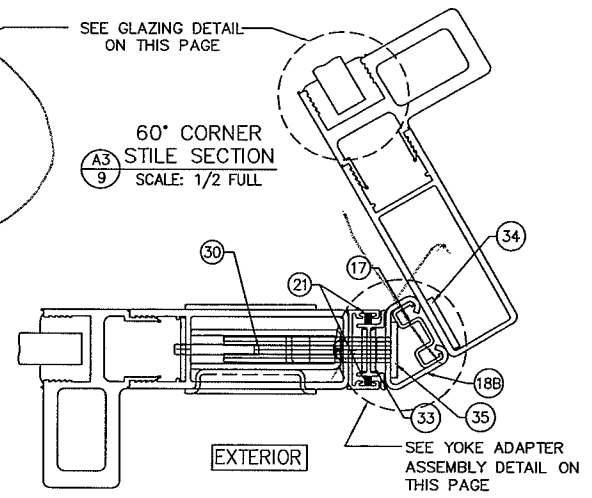
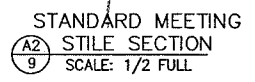

SEE YOKE ADAPTER ASSEMBLY DETAIL ON THIS PAGE

YOKE ADAPTER ASSEMBLY DETAIL

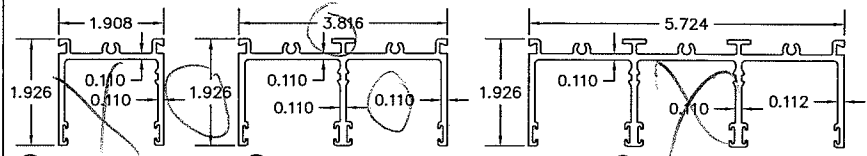
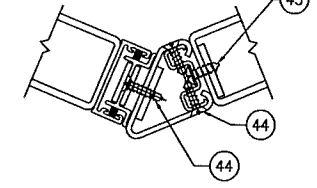

(1A) HEAD TRACK SINGLE RUN (1B) HEAD TRACK DOUBLE RUN (1C) HEAD TRACK TRIPLE RUN

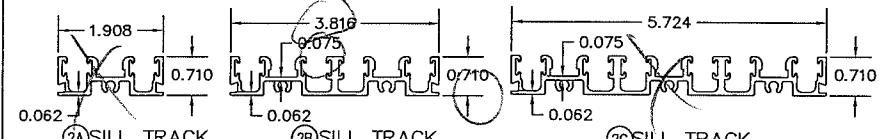

(2A) SILL TRACK SINGLE RUN (2B) SILL TRACK DOUBLE RUN (2C) SILL TRACK TRIPLE RUN

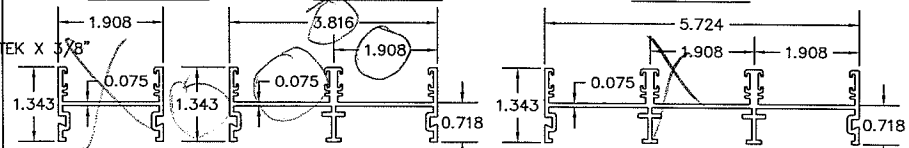

(3A) SIDE TRACK SINGLE RUN (3B) SIDE TRACK DOUBLE RUN (3C) SIDE TRACK TRIPLE RUN

SEE GLAZING DETAIL ON THIS PAGE

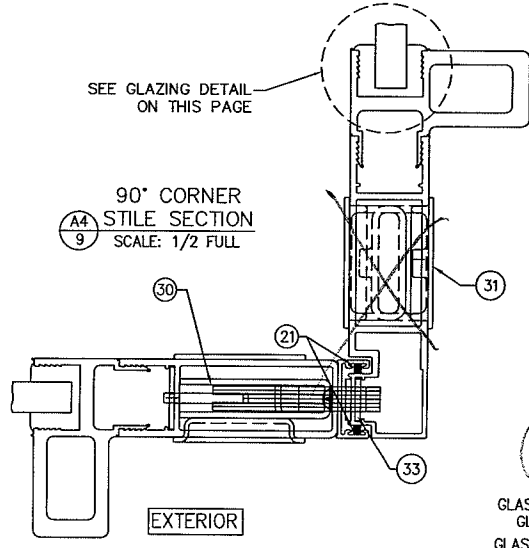
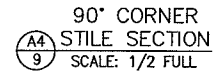

GLAZING DETAIL

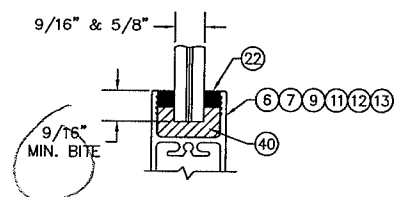

GLASS "A": 5/8" THICK LAMINATED, IMPACT GLASS BY GLASSLAM (1/4" H.S./0.100 SAFETY PLUS/ 1/4" H.S.
 GLASS "B": 9/16" THICK LAMINATED, IMPACT GLASS BY OLD CASTLE (1/4" H.S./0.100 SAFETY PLUS/ 1/4" H.S.

DRAWN BY: WDE	DATE: 01/04/08	TITLE: SECTION DETAILS
SCALE: 1:2	REV:	
CONFIGURATION:		

NORWOOD 3070HI '08 CERTIFICATION

FLEETWOOD WINDOWS & DOORS
 FleetwoodUSA.com
 DRAWING NUMBER: CERT-DANFOR-LS9
 SHEET: 10 OF 10



Architectural Testing, Inc.
 Test sample complies with these details
 Exceptions are noted

7 8 6 7 4

FEB 0 4 2008

Report#

Date

Test TW

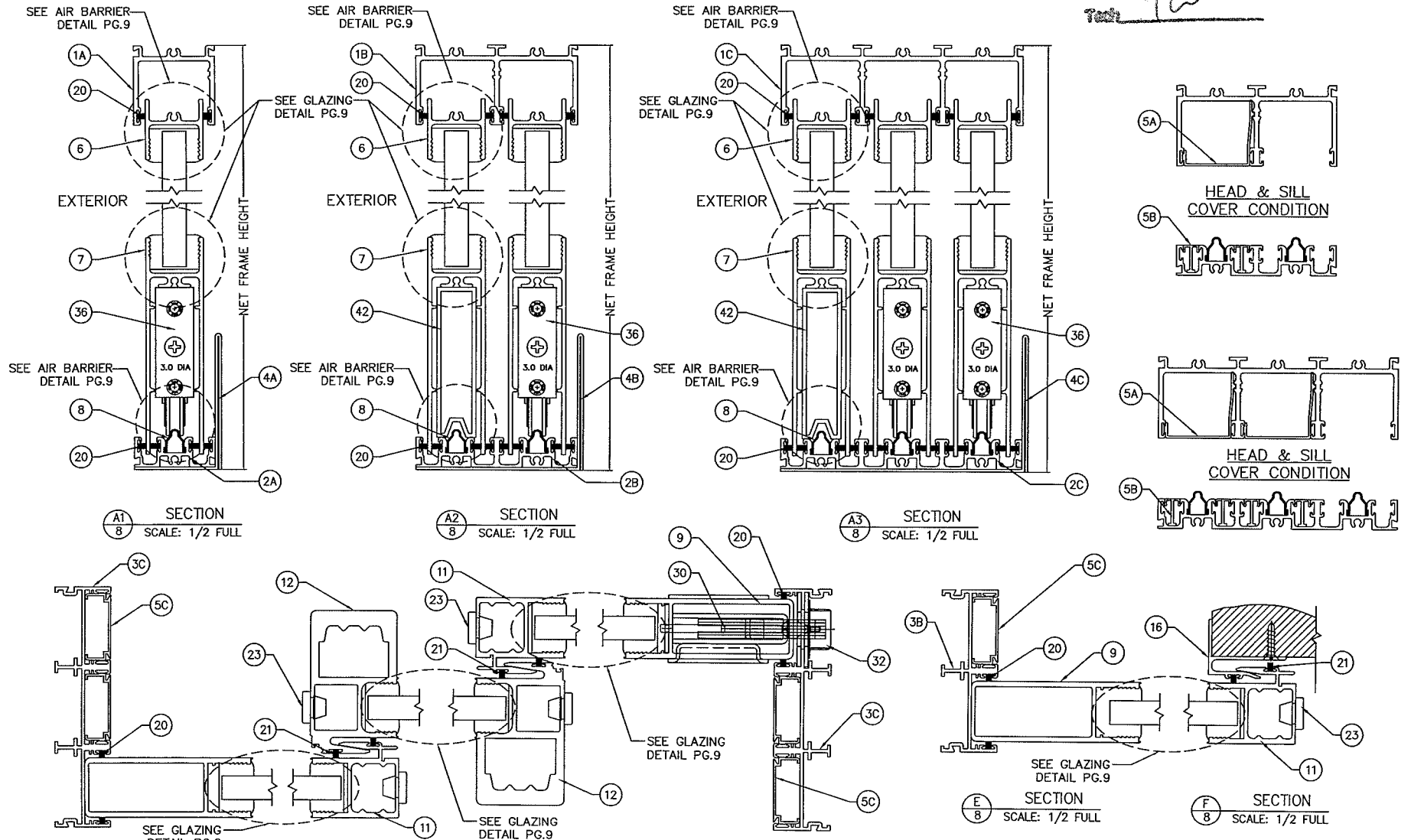

A1 SECTION
 SCALE: 1/2 FULL

A2 SECTION
 SCALE: 1/2 FULL

A3 SECTION
 SCALE: 1/2 FULL

B SECTION
 SCALE: 1/2 FULL

C1 SECTION
 SCALE: 1/2 FULL

C2 SECTION
 SCALE: 1/2 FULL

D SECTION
 SCALE: 1/2 FULL

E SECTION
 SCALE: 1/2 FULL

F SECTION
 SCALE: 1/2 FULL

DRAWN BY: WDE	DATE: 01/04/08	TITLE: SECTION DETAILS
SCALE: 1:2	REV:	
CONFIGURATION:		

NORWOOD 3070HI
 '08 CERTIFICATION

	FLEETWOOD
	WINDOWS & DOORS
	FleetwoodUSA.com
DRAWING NUMBER: CERT-DADFOR-SR	SHEET 8 OF 10