

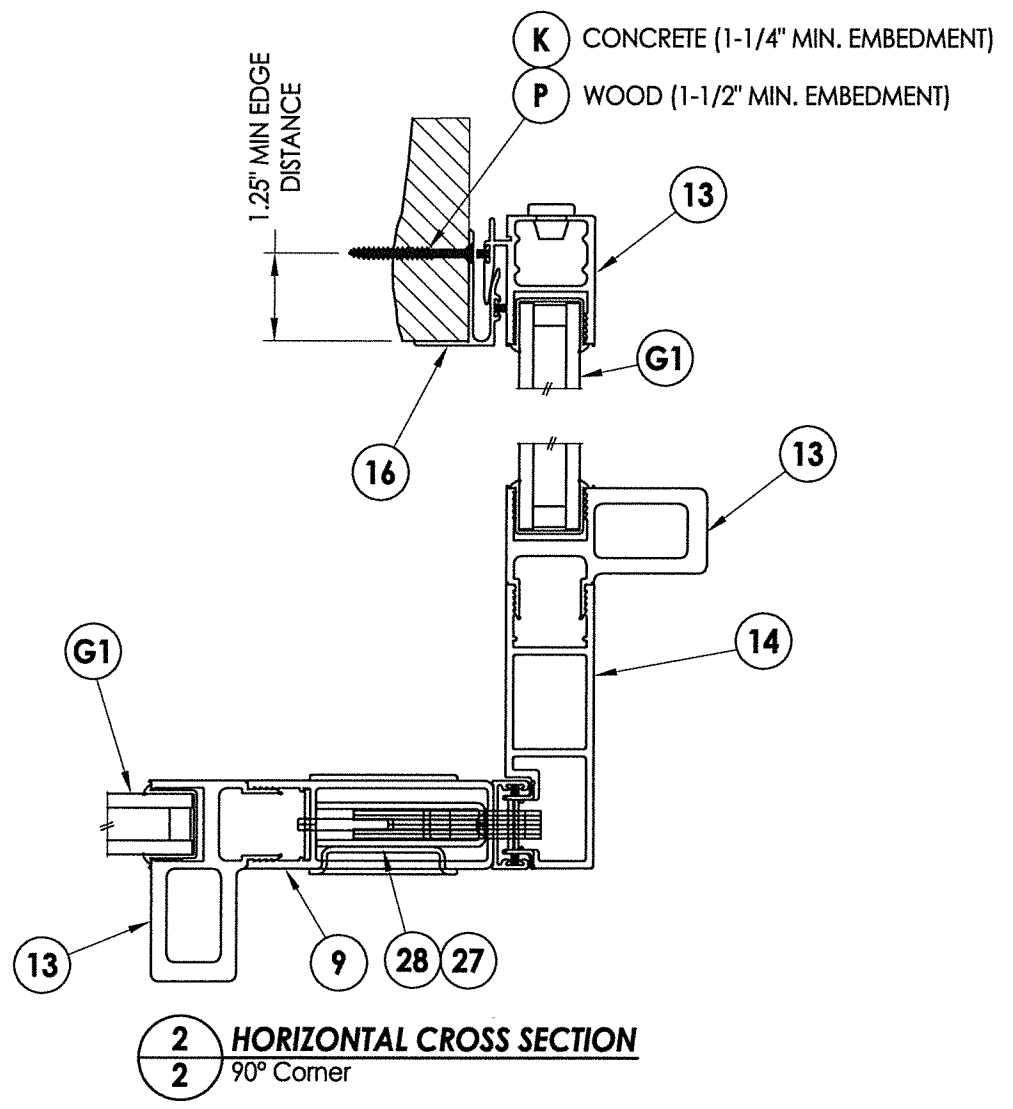

\\c001\wbc\clients\PERMANENTIA - Florida Product Approvals\EL-15560 Sliding Patio Doors\C - Drawings\EL-15560\EL-15560.8-10.dwg

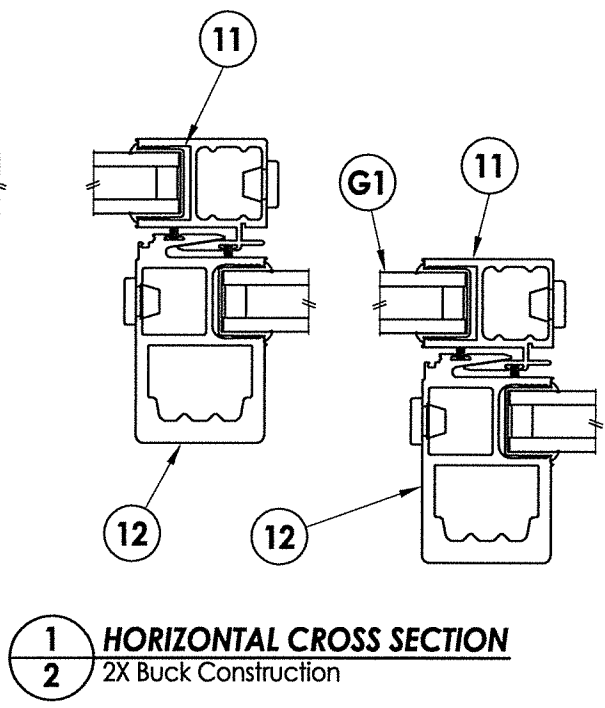
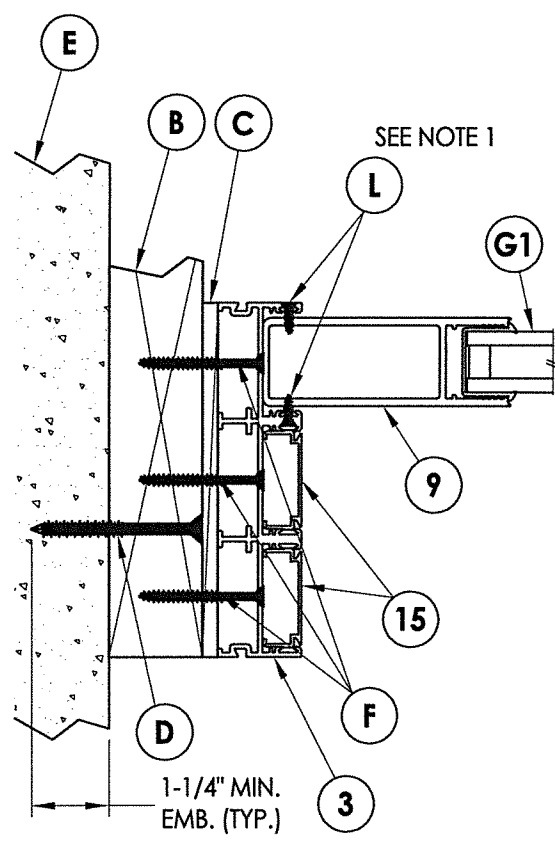
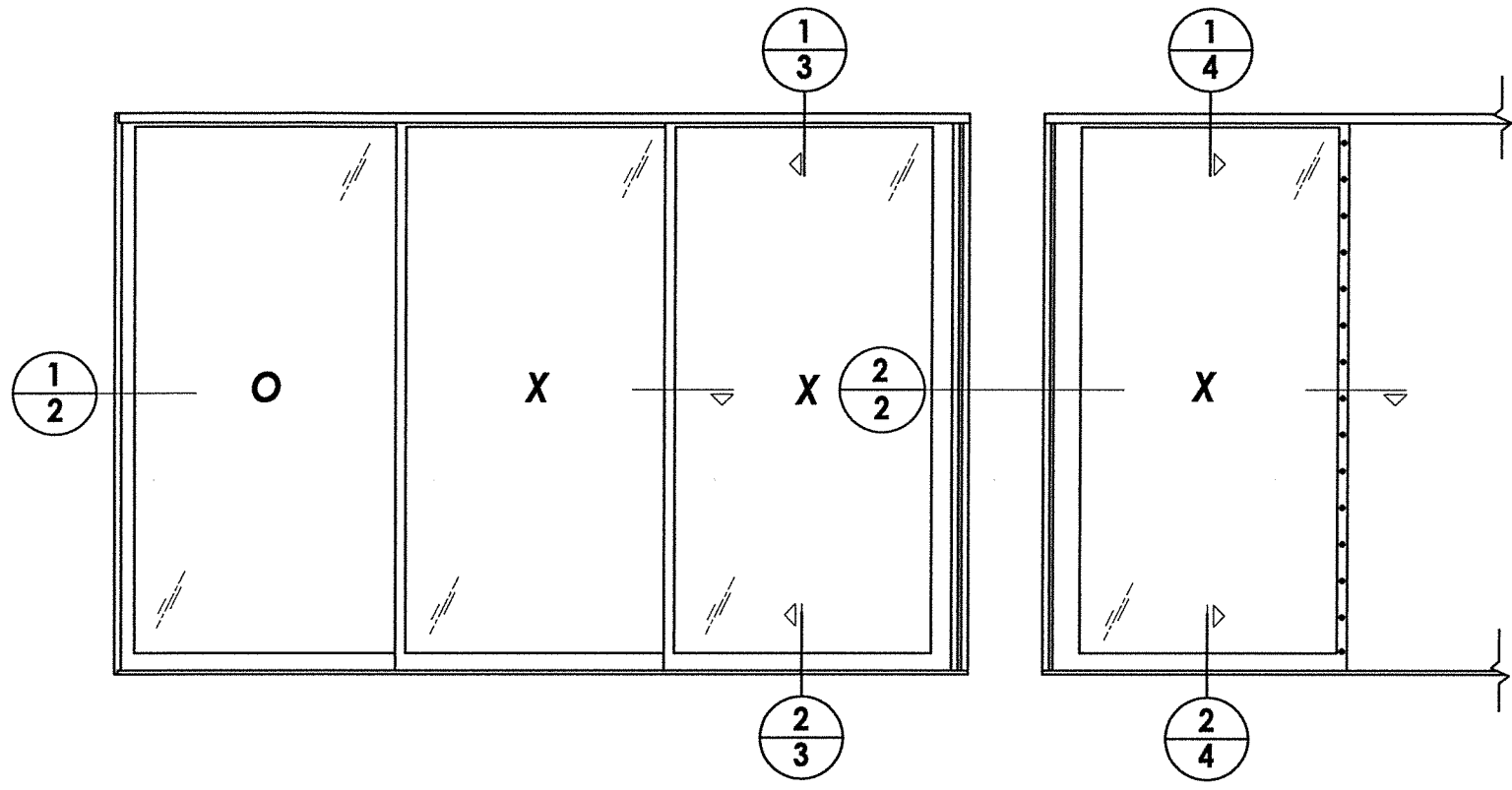

NOTE:  
1. Fixed panel screws located 39" from each end.

August 10, 2020  
 Documents Prepared By:  
 Lyndon F. Schmidt  
 P.E. No. 43409  
 R.W. BUILDING CONSULTANTS, INC.  
 P.O. Box 230, Valrico, FL 33595  
 Phone No.: 813.659.9197  
 FBPE Registry No. 9813

PRODUCT:		FLEETWOOD WINDOWS & DOORS	
PART OR ASSEMBLY:		HORIZONTAL CROSS SECTIONS	
NO.	DATE	REVISIONS	BY
4	8/10/20	UPDATE TO 7th ED. (2020) FBC	DAC
3	08/08/17	UPDATE TO 6TH ED. (2017) FBC	LFS
2	8/06/15	CLARIFY MAX PANEL SIZE & CHANGE NAME	JK
1	04/22/15	UPDATE TO 5TH ED. (2014) FBC	JK
DATE: 3/20/14		SCALE: N.T.S.	
DWG. BY: JK		CHK. BY: LFS	
DRAWING NO.: FL-15560.9		SHEET 2 OF 8	

\\dc01\rbw\clients\Fleetwood PERMANENT\A - Florida Product Approvals\FL-15560 Sliding Patio Doors\C - Drawings\FL 15560 (2020)\FL-15560.8-.10.dwg

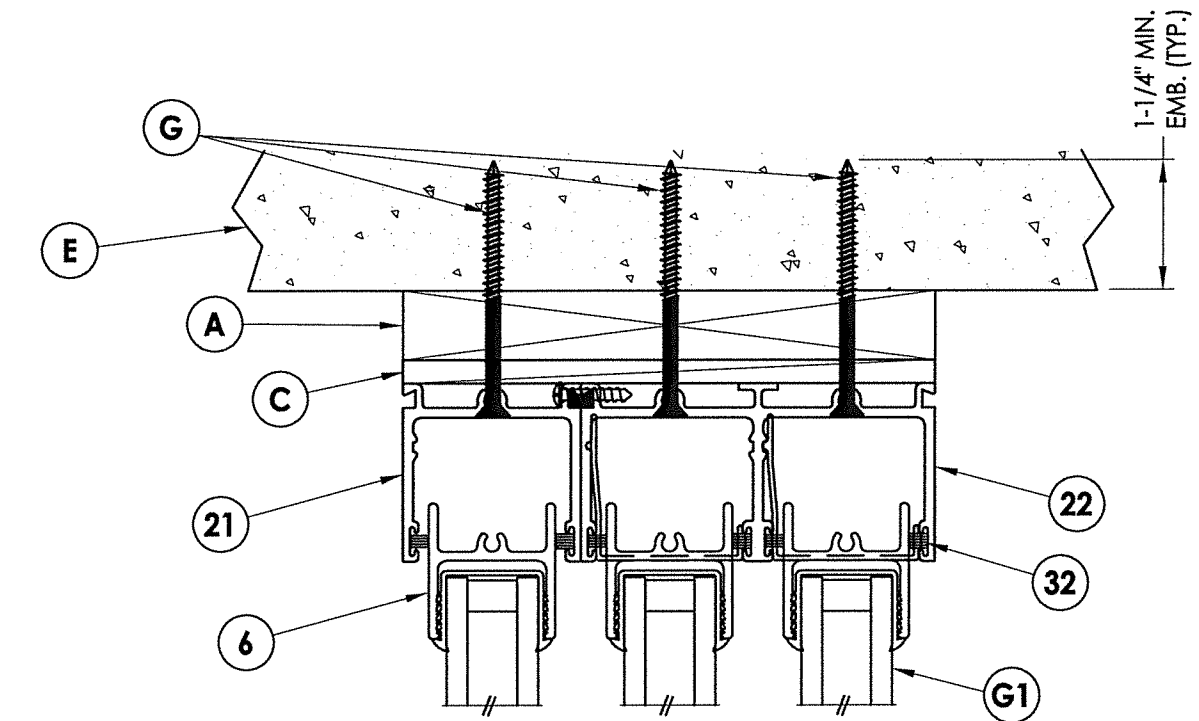

**1 VERTICAL CROSS SECTION**  
3 1X Buck Construction

EXTERIOR

INTERIOR

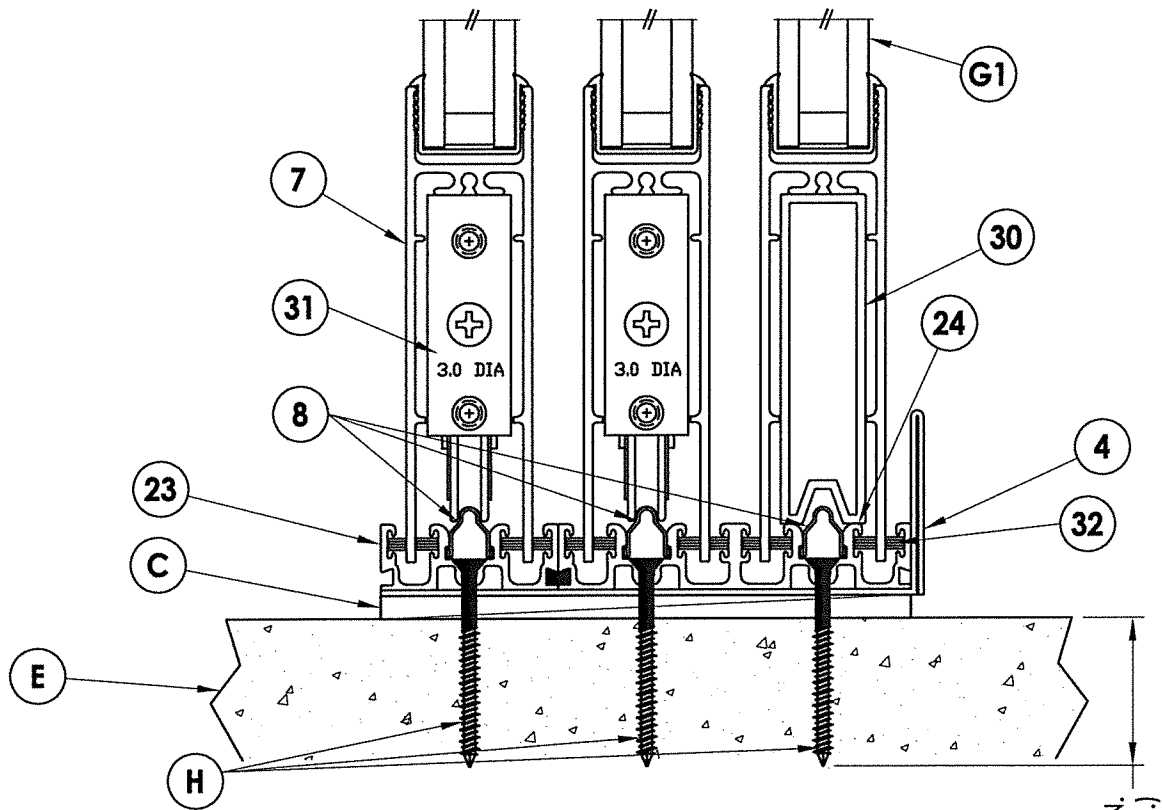

**2 VERTICAL CROSS SECTION**  
3 Direct to masonry

1-1/4" MIN.  
EMB. (TYP.)

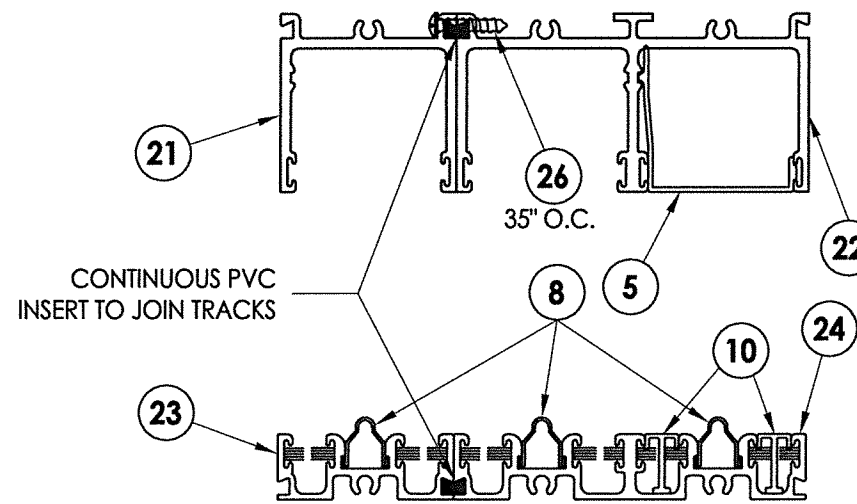

**HEAD & SILL COVER CONDITION**

**NOTE:**

1. A full-depth cut-out (1" wide x 3/16" tall) in track base is necessary to allow for water drainage (12" from each end and 24" o.c.).

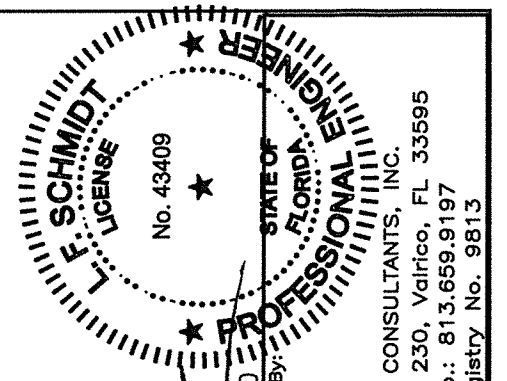

August 10, 2020  
 Documents Prepared By:  
 Lyndon F. Schmidt  
 P.E. No. 43409  
 RW BUILDING CONSULTANTS, INC.  
 P.O. Box 230, Vairico, FL 33595  
 Phone No.: 813.659.9197  
 FBPE Registry No. 9813

PRODUCT:  
 FLEETWOOD WINDOWS & DOORS  
 PART OR ASSEMBLY:  
 VERTICAL CROSS SECTIONS

NO.	DATE	REVISIONS
4	8/10/20	UPDATE TO 7th ED. (2020) FBC DAC
3	08/08/17	UPDATE TO 6TH ED. (2017) FBC LFS
2	8/06/15	CLARIFY MAX PANEL SIZE & CHANGE NAME JK
1	04/22/15	UPDATE TO 5TH ED. (2014) FBC JK
		BY

DATE: 3/20/14  
 SCALE: N.T.S.  
 DWG. BY: JK  
 CHK. BY: LFS  
 DRAWING NO.: FL-15560.9  
 SHEET 3 OF 8

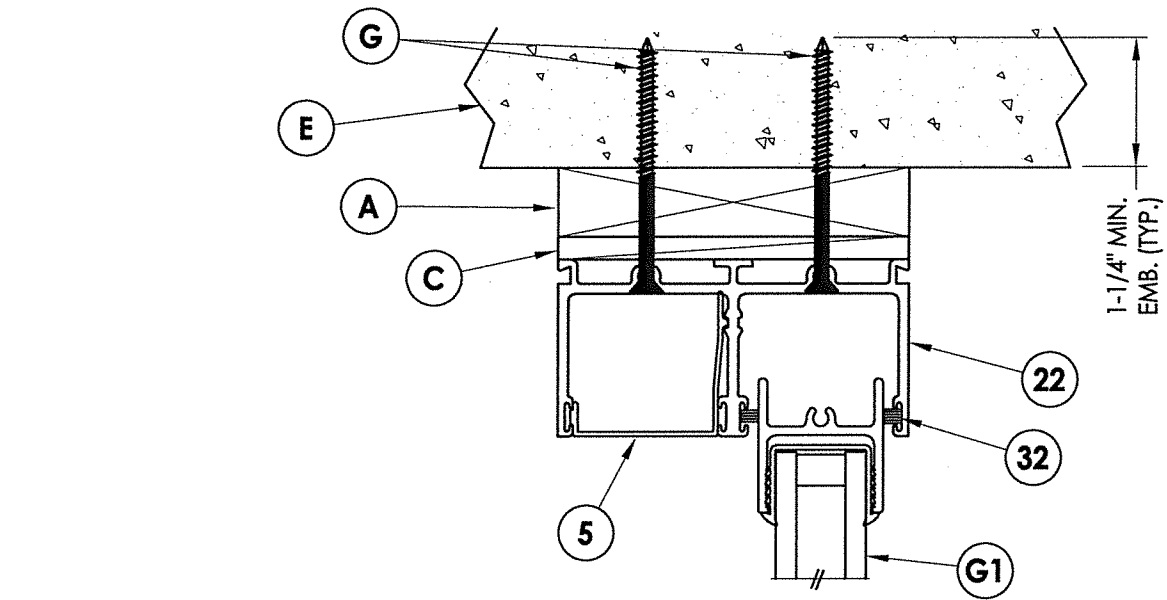

**1 VERTICAL CROSS SECTION**  
4 1X Buck Construction

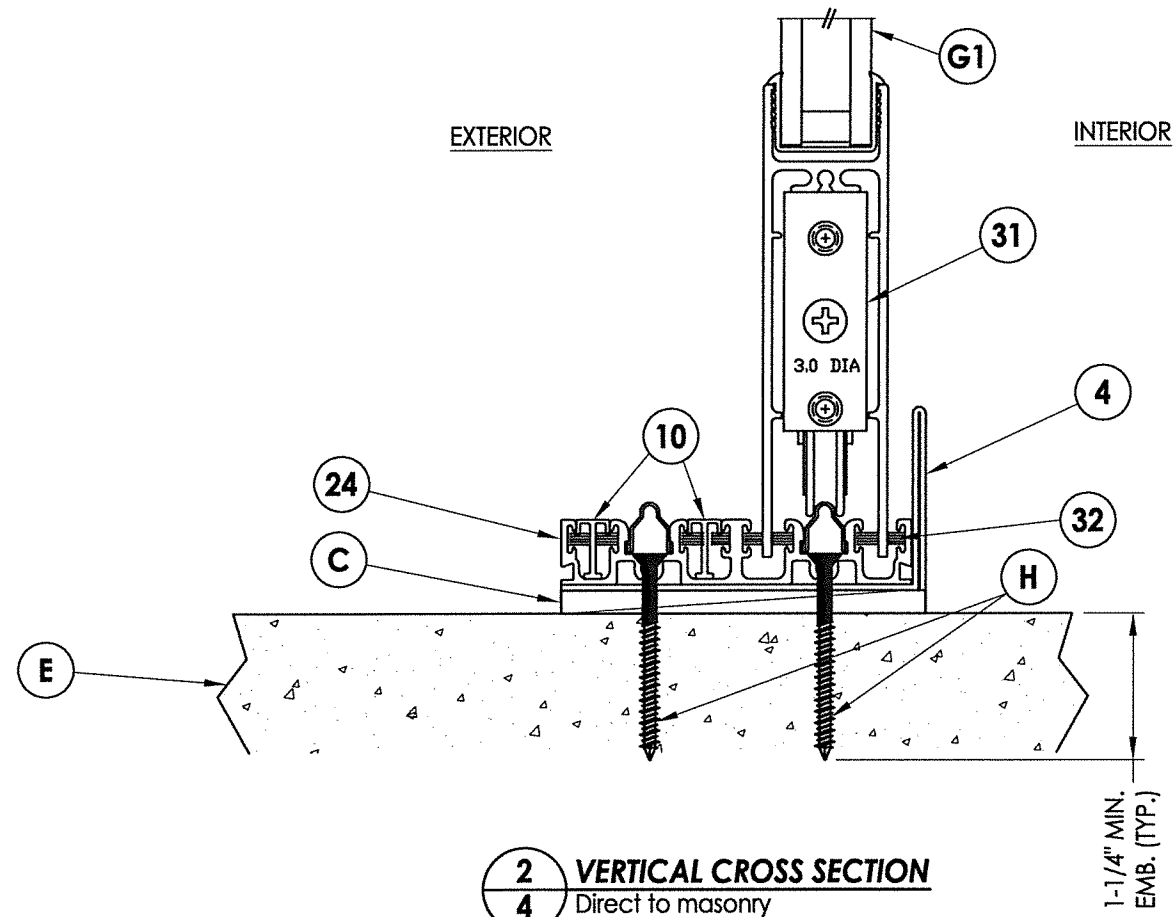

**2 VERTICAL CROSS SECTION**  
4 Direct to masonry

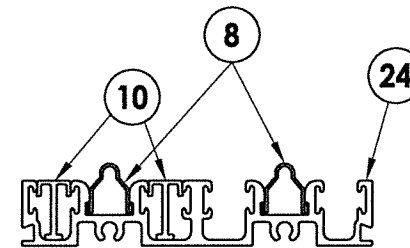
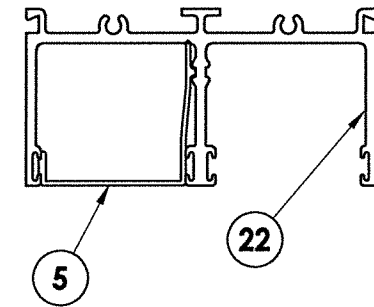

**HEAD & SILL COVER CONDITION**

NOTE:  
1. A full-depth cut-out (1" wide x 3/16" tall) in track base is necessary to allow for water drainage (12" from each end and 24" o.c.).

August 10, 2020  
Documents Prepared By: Lyndon F. Schmidt  
P.E. No. 43409

**L. F. SCHMIDT**  
LICENSE  
No. 43409  
STATE OF FLORIDA  
PROFESSIONAL ENGINEER

*RW*  
BUILDING CONSULTANTS, INC.  
P.O. Box 230, Vairico, FL 33595  
Phone No.: 813.659.9197  
FBPE Registry No. 9813

PRODUCT:		FLEETWOOD WINDOWS & DOORS	
PART OR ASSEMBLY:		VERTICAL CROSS SECTIONS	
NO.	DATE	REVISIONS	
4	8/10/20	UPDATE TO 7th ED. (2020)	DAC
3	08/08/17	UPDATE TO 6TH ED. (2017)	LFS
2	8/06/15	CLARIFY MAX PANEL SIZE & CHANGE NAME	JK
1	04/22/15	UPDATE TO 5TH ED. (2014)	JK
			BY

DATE: 3/20/14  
SCALE: N.T.S.  
DWG. BY: JK  
CHK. BY: LFS  
DRAWING NO.: FL-15560.9  
SHEET 4 OF 8

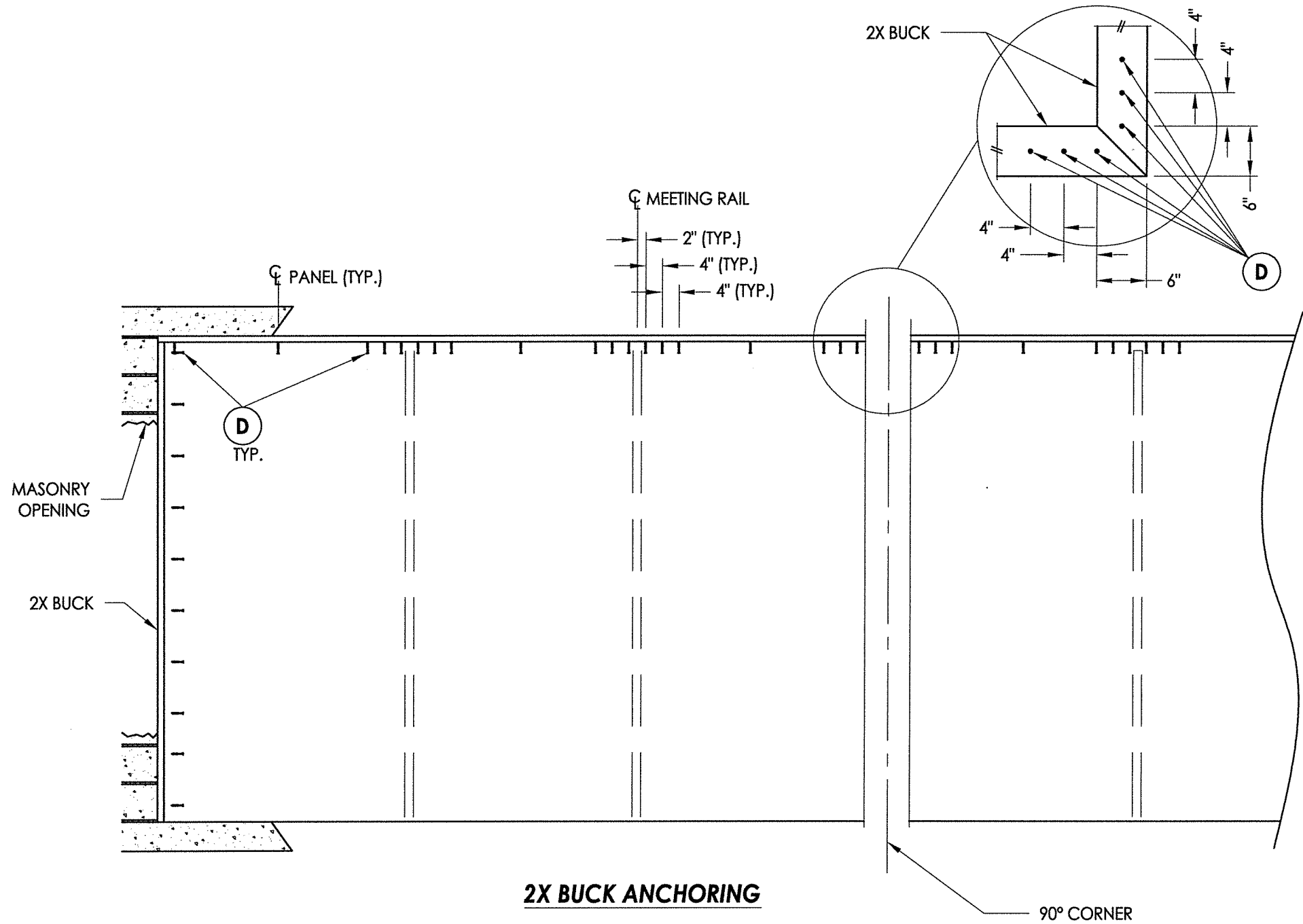

**2X BUCK ANCHORING**

90° CORNER

**CONCRETE ANCHOR NOTES:**

1. Concrete anchor locations at the corners may be adjusted to maintain the min. edge distance to mortar joints.
2. Concrete anchor locations noted as "MAX. ON CENTER" must be adjusted to maintain the min. edge distance to mortar joints, additional concrete anchors may be required to ensure the "MAX. ON CENTER" dimension are not exceeded.
3. Concrete anchor table:

ANCHOR TYPE	ANCHOR SIZE	MIN. EMBEDMENT	MIN. CLEARANCE TO MASONRY EDGE	MIN. CLEARANCE TO ADJACENT ANCHOR
ITW TAPCON®	1/4"	1-1/4"	2"	4"
DeWALT ULTRACON+®	1/4"	1-1/4"	2-1/2"	4"

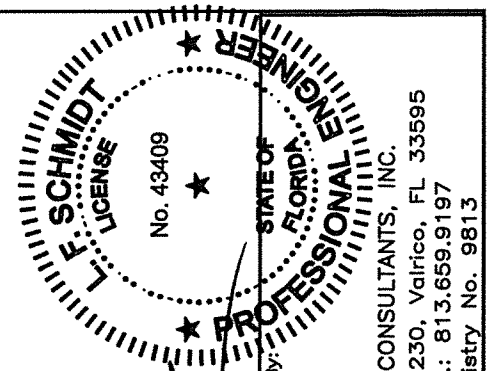

August 10, 2020  
 Documents Prepared By:  
 Lyndon F. Schmidt  
 P.E. No. 43409

*RW* BUILDING CONSULTANTS, INC.  
 P.O. Box 230, Valrico, FL 33595  
 Phone No.: 813.659.9197  
 FBPE Registry No. 9813

PRODUCT:		FLEETWOOD WINDOWS & DOORS	
PART OR ASSEMBLY:		BUCK ANCHORING	
NO.	DATE	REVISIONS	
4	8/10/20	UPDATE TO 7TH ED. (2020) FBC	DAC
3	08/08/17	UPDATE TO 6TH ED. (2017) FBC	LFS
2	8/06/15	CLARIFY MAX PANEL SIZE & CHANGE NAME	JK
1	04/22/15	UPDATE TO 5TH ED. (2014) FBC	JK
			BY

DATE: 3/20/14  
 SCALE: N.T.S.  
 DWG. BY: JK  
 CHK. BY: LFS  
 DRAWING NO.: FL-15560.9  
 SHEET 5 OF 8

\\dc01\rbw\clients\Fleetwood PERMANENTA - Florida Product Approvals\FL-15560 Sliding Patio Doors\C - Drawings\FL-15560 (2020)\FL-15560.8-10.dwg

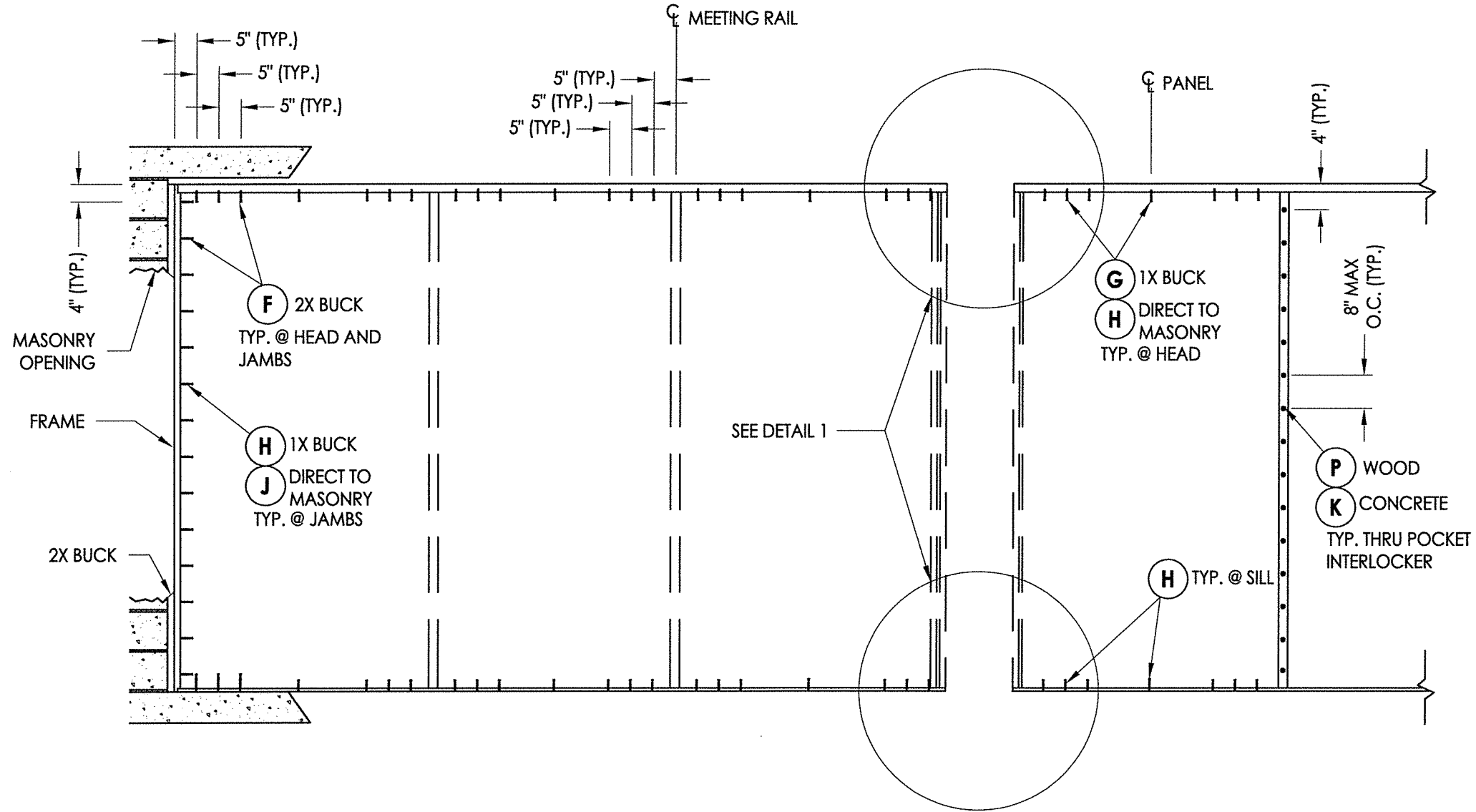

**FRAME ANCHORING**

(NOTE: 1 ANCHOR REQUIRED PER EACH TRACK RUN @ EACH LOCATION)

**CONCRETE ANCHOR NOTES:**

1. Concrete anchor locations at the corners may be adjusted to maintain the min. edge distance to mortar joints.
2. Concrete anchor locations noted as "MAX. ON CENTER" must be adjusted to maintain the min. edge distance to mortar joints, additional concrete anchors may be required to ensure the "MAX. ON CENTER" dimension are not exceeded.
3. Concrete anchor table:

ANCHOR TYPE	ANCHOR SIZE	MIN. EMBEDMENT	MIN. CLEARANCE TO MASONRY EDGE	MIN. CLEARANCE TO ADJACENT ANCHOR
ITW TAPCON®	3/16"	1-1/4"	2"	1-7/8"
DeWALT ULTRACON+®	1/4"	1-1/4"	1"	6"

**WOOD SCREW INSTALLATION NOTES:**

1. Maintain a minimum 3/4" edge distance, 1" end distance, & 1" o.c. spacing of wood screws to prevent the splitting of wood.

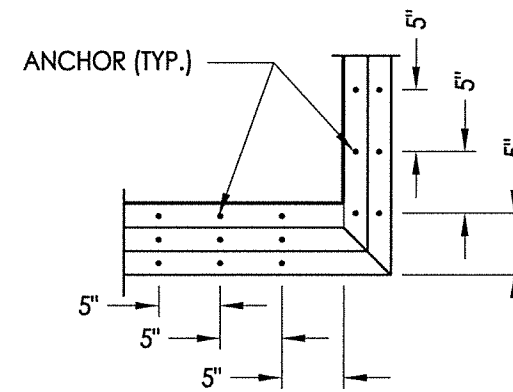

**DETAIL 1**

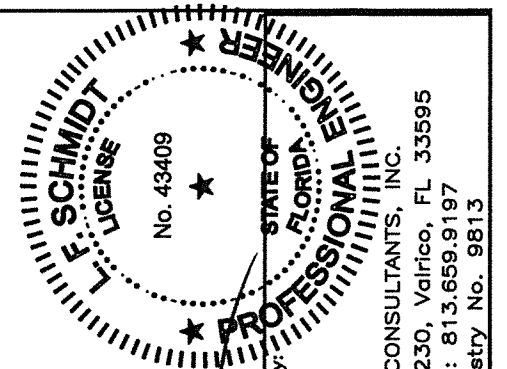

August 10, 2020  
 Documents Prepared By:  
 Lyndon F. Schmidt  
 P.E. No. 43409  
 R.W. BUILDING CONSULTANTS, INC.  
 P.O. Box 230, Valrico, FL 33595  
 Phone No.: 813.659.9197  
 FBPE Registry No. 9813

PRODUCT:		FLEETWOOD WINDOWS & DOORS	
PART OR ASSEMBLY:		FRAME ANCHORING	
4	8/10/20	UPDATE TO 7TH ED. (2020) FBC	DAC
3	08/08/17	UPDATE TO 6TH ED. (2017) FBC	LFS
2	8/06/15	CLARIFY MAX PANEL SIZE &	JK
1	04/22/15	CHANGE NAME	JK
		UPDATE TO 5TH ED. (2014) FBC	BY
	NO. DATE		
REVISIONS			
DATE: 3/20/14			
SCALE: N.T.S.			
DWG. BY: JK			
CHK. BY: LFS			
DRAWING NO.: FL-15560.9			
SHEET 6 OF 8			

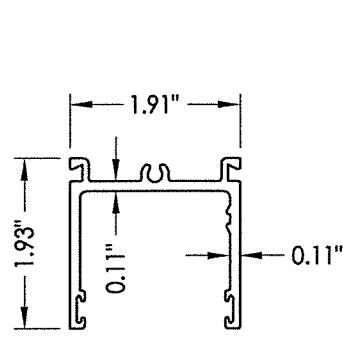

**21 HEAD TRACK**  
1 Run

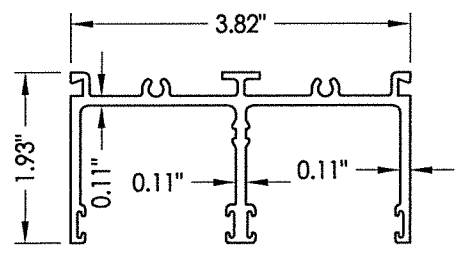

**22 HEAD TRACK**  
2 Runs

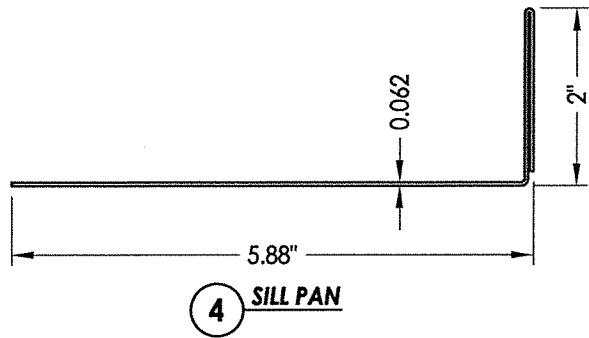

**4 SILL PAN**

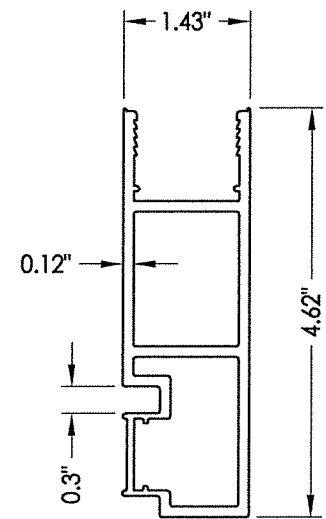

**14 90° CORNER LOCK STILE**

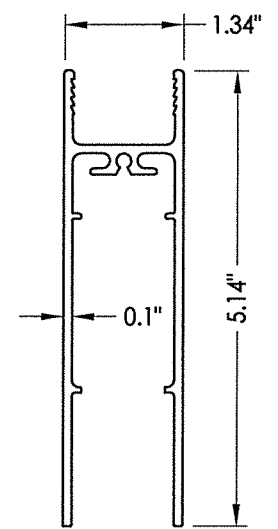

**7 BOTTOM RAIL**

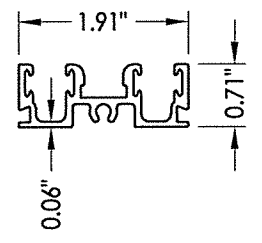

**23 SILL TRACK**  
1 Run

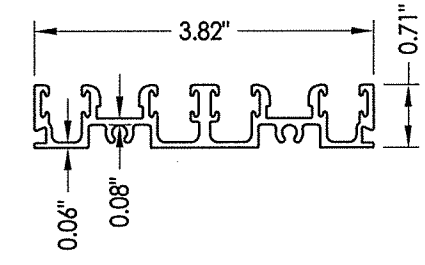

**2 SILL TRACK**  
2 Runs

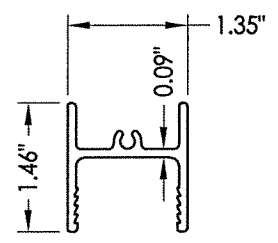

**6 TOP RAIL**

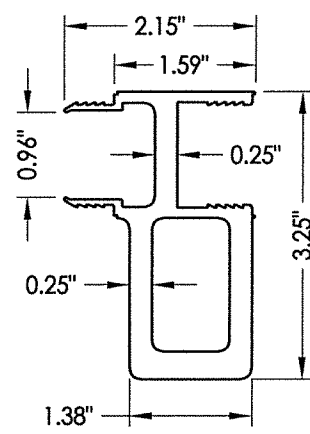

**13 WINDLOAD ADAPTER**

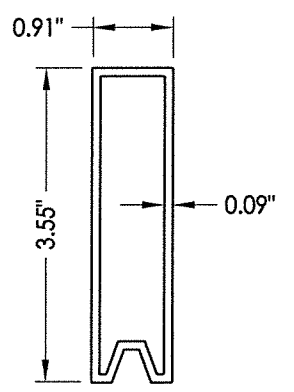

**30 PANEL SETTING BLOCK**

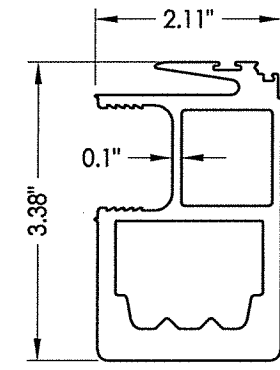

**12 INTERLOCK STILE**  
High Performance

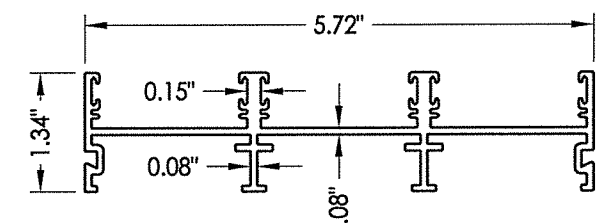

**3 JAMB TRACK**

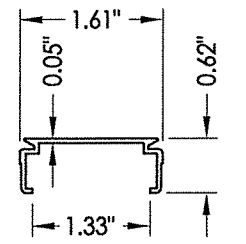

**15 JAMB CHANNEL FILLER**

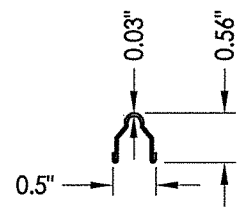

**8 TRACK**

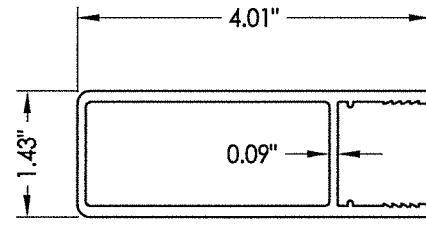

**9 STILE**

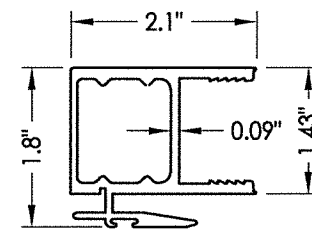

**11 INTERLOCK STILE**  
Standard

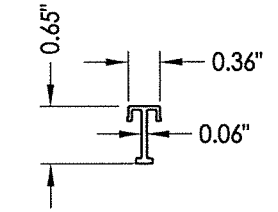

**10 SILL CHANNEL FILLER**

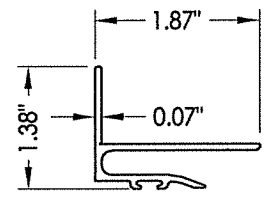

**16 POCKET INTERLOCKER**

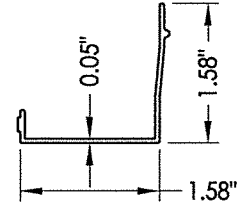

**5 HEAD CHANNEL FILLER**

August 10, 2020  
 Documents Prepared By: Lyndon F. Schmidt  
 P.E. No. 43409  
 No. 43409  
 F. SCHMIDT  
 LICENSE  
 STATE OF FLORIDA  
 PROFESSIONAL ENGINEER  
 R.W. BUILDING CONSULTANTS, INC.  
 P.O. Box 230, Valrico, FL 33595  
 Phone No.: 813.659.9197  
 FBPE Registry No. 9813

PRODUCT:		FLEETWOOD WINDOWS & DOORS	
PART OR ASSEMBLY:		COMPONENTS	
NO.	DATE	REVISIONS	BY
4	8/10/20	UPDATE TO 7th ED.(2020) FBC	DAC
3	08/08/17	UPDATE TO 6TH ED. (2017) FBC	LFS
2	8/06/15	CLARIFY MAX. PANEL SIZE & CHANGE NAME	JK
1	04/22/15	UPDATE TO 5TH ED. (2014) FBC	JK

DATE: 3/20/14  
 SCALE: N.T.S.  
 DWG. BY: JK  
 CHK. BY: LFS  
 DRAWING NO.: FL-15560.9  
 SHEET 7 OF 8

\\dc01\rbw\clients\Fleetwood PERMANENT\A - Florida Product Approvals\FL-15560 Sliding Patio Doors\C - Drawings\FL 15560 (2020)\FL-15560.8-10.dwg

BILL OF MATERIALS		
ITEM #	DESCRIPTION	MATERIAL
A	1X BUCK SG >= 0.55	WOOD
B	2X BUCK SG >= 0.55	WOOD
C	1/4" MAX. SHIM SPACE	-
D	1/4" X 2-3/4" DeWALT OR ITW PFH CONCRETE SCREW	STEEL
E	MASONRY - 3,000 PSI MIN. CONCRETE CONFORMING TO ACI 301 OR HOLLOW BLOCK CONFORMING TO ASTM C90	CONCRETE
F	#10 X 2" PFH SMS (1" MIN. EMBEDMENT)	STEEL
G	3/16" X 2-3/4" ITW PFH CONCRETE SCREW	STEEL
H	3/16" X 2-1/4" ITW PFH CONCRETE SCREW	STEEL
J	3/16" X 3-1/4" ITW PFH CONCRETE SCREW	STEEL
K	1/4" X 1- 3/4" DeWALT PFH CONCRETE SCREW	STEEL
L	#8 X 1/2" PFH SMS	STEEL
P	#10 X 2" PFH SMS (1-1/2" MIN. EMBEDMENT)	STEEL
3	JAMB TRACK (3 RUNS)	6063-T6 ALUM
4	SILL PAN (TRIPLE RUN)	5052 -ALUM
5	HEAD CHANNEL FILLER	6063-T6 ALUM
6	TOP RAIL	6063-T6 ALUM
7	BOTTOM RAIL	6063-T6 ALUM
8	TRACK	S.S.
9	STILE	6063-T6 ALUM
10	SILL CHANNEL FILLER	6063-T6 ALUM
11	STANDARD INTERLOCK STILE	6063-T6 ALUM
12	HIGH PERFORMANCE INTERLOCK STILE	6063-T6 ALUM
13	WINDLOAD ADAPTER	6063-T6 ALUM
14	90° CORNER LOCK STILE	6063-T6 ALUM
15	JAMB CHANNEL FILLER	6063-T6 ALUM
16	POCKET INTERLOCKER	6063-T6 ALUM
21	HEAD TRACK (1 RUN)	6063-T6 ALUM
22	HEAD TRACK (2 RUNS)	6063-T6 ALUM
23	SILL TRACK (1 RUN)	6063-T6 ALUM
24	SILL TRACK (2 RUNS)	6063-T6 ALUM
26	#8 X 3/4" PPH SMS	STEEL
27	PRIMARY LATCH	-
28	SECONDARY LATCH	-
29	HANDLE SET	-
30	PANEL SETTING BLOCK	6063-T6 ALUM
31	MAMMOTH ROLLER ASSEMBLY	-
32	CENTER-FIN WEATHERSEAL .290 HIGH PILE (AMESBURY 43629-270)	-
33	HEAVY DENSITY WEATHERSEAL .300 HIGH PILE (AMESBURY 413330-270)	-

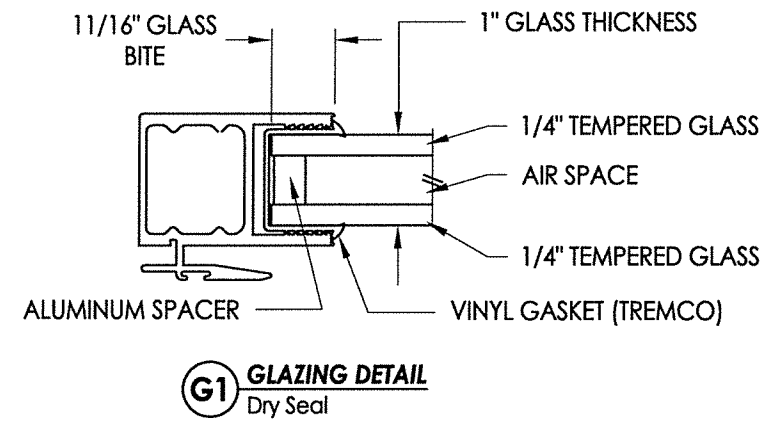

August 10, 2020  
 Documents Prepared By:  
 Lyndon F. Schmidt  
 P.E. No. 43409

R.W.  
 BUILDING CONSULTANTS, INC.  
 P.O. Box 230, Vairco, FL 33595  
 Phone No.: 813.659.9197  
 FBPE Registry No. 9813

PRODUCT:		FLEETWOOD WINDOWS & DOORS	
PART OR ASSEMBLY:		BILL OF MATERIALS AND GLAZING DETAILS	
4	8/10/20	UPDATE TO 7th ED. (2020)	DAC
3	08/08/17	UPDATE TO 6TH ED. (2017)	LFS
2	8/06/15	CLARIFY MAX. PANEL SIZE & CHANGE NAME	JK
1	04/22/15	UPDATE TO 5TH ED. (2014)	JK
	NO.	DATE	BY
REVISIONS			
DATE: 3/20/14			
SCALE: N.T.S.			
DWG. BY: JK			
CHK. BY: LFS			
DRAWING NO.: FL-15560.9			
SHEET 8 OF 8			