

**Table of Contents**

**I. Care and Maintenance..... 2**

**II. Tools / Materials, Sealant Requirements, & Anchor Instructions ..... 2**

**III. Assembly and Installation ..... 2**

**IV. Structure Verification & Arche-Duct Installation ..... 3**

    1. Opening Verification.....3

    2. Pre-Fit and Leveling.....3

    3. Arche-Duct Installation.....4

    4. Arche-Duct Water Test.....4

    5. Arche-Duct Install.....4

    6. Confirm Weeping Slots .....5

    7. Backfill.....5

**V. Frame Assembly ..... 5**

**VI. Frame Installation ..... 5**

**VII. Panel Assembly (when panels received unassembled)..... 7**

**VIII. Glazing Instructions ..... 8**

**IX. Panel Installation ..... 9**

**X. Flashing after Installation ..... 10**

**XI. Finished Flooring Installation..... 11**

**Appendix A: Stucco Surround Application (Optional)..... 12**

**Appendix B: Panel Squaring Instructions ..... 13**

## I. Care and Maintenance

This product is factory finished. Please handle with extreme care. Protect all exposed surfaces from contact with caustics, corrosives, solvents, abrasions, impacts, wet packing material etc.

**FAILURE TO DO SO WILL NULLIFY THE WARRANTY.** Before **ANY CLEANING**, review the Care & Maintenance Instructions (go to [www.fleetwoodusa.com](http://www.fleetwoodusa.com) for more information).

**Contact the local dealer with any questions or concerns.** Fleetwood strongly recommends that all products be cleaned after installation and totally protected from construction debris and equipment.

## II. Tools / Materials, Sealant Requirements, & Anchor Instructions

**Tool Requirements:** Tape measure, level, shims, nails, rubber mallet, putty knife, screws, sealant, caulk gun, backer rod, 6mm hex wrench, scissors or utility knife, drill bit, drive bit and powered drill.

### Sealant Requirements

- The sealant referred to within this document for seals associated with the assembly of the product should conform to **AAMA 800-16**. It is recommended that all other sealants should also conform to **AAMA 800-16** but may be a sealant recommended and approved by the sealant manufacturer that is compatible with the framing, finish and surrounding materials.
- All sealant bead sizes must conform to the sealant manufacturers' size requirements.
- The Owner / General Contractor is responsible for identifying the need for any additional sealant to be applied by others. Such sealant shall be elastomeric material, with the framing, finish and surrounding materials.

### Anchor Instructions

- Structural engineer to determine anchor quantity and spacing for design load requirements.
- Proper isolating material must be between dissimilar surfaces (i.e. block/concrete & metals).

## III. Assembly and Installation

**It is essential that each Fleetwood product be assembled and glazed in accordance with AAMA standards and factory instructions.** It is the installer's responsibility to ensure that each Fleetwood product is assembled, glazed and installed and completely sealed to ensure that the product is leak-free and operates correctly. **Installation of Fleetwood products must be in accordance with the standards set forth in ASTM E 2112.** If there are any questions regarding the installation of a Fleetwood product contact the factory customer service department.

Due to inherent manufacturing tolerances Fleetwood has provided this product with recommended field glazed weather-stripping. If the provided weather-stripping does not ensure an optimum fit of glass to frame the Fleetwood Authorized Dealer should contact Customer Service for an expedited **NO CHARGE** shipment of replacement weather-stripping.

#### IV. Structure Verification & Arche-Duct Installation

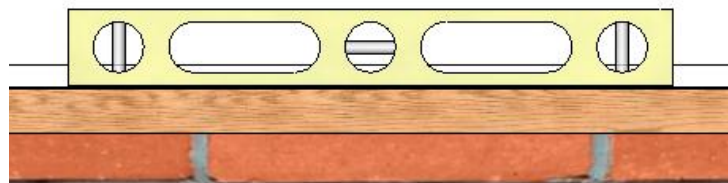
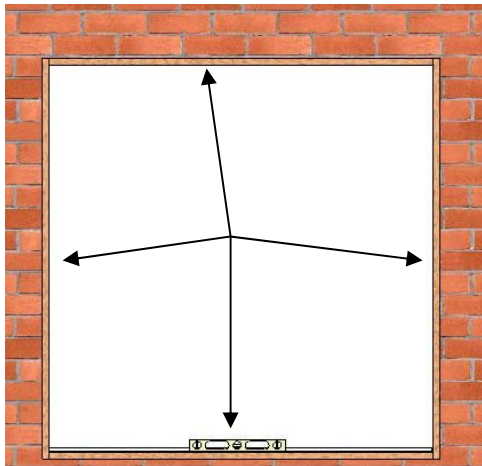
**Note:** If the factory provided Arche-Duct drain system is not desired, the product warranty will remain intact if the substitute system emulates the essential factory design.

##### 1. Opening Verification

- Check the measurements of the opening and verify that the door will fit into the opening. Measure all four sides of the opening to make sure there is a clearance of 1/2" in width and 1/4" in height.
- Remove the door(s) from the packaging and lay it in front of the opening. Check width and height dimensions.
- Verify the opening is plumb and level.

##### 2. Pre-Fit and Leveling

- Place the Arche-Duct drain system into the opening and determine any leveling that must be done prior to installation (Figure 1). Prepare relief areas for the PVC drain flange(s).
- Shim as necessary to stabilize the entire depth and length of the Arche-Duct. No unsupported width of more than 8" is allowed. Shim to be load bearing, non-porous, non-absorbent and inorganic.
- If more than 1/8" shim height is required, it is recommended that pouring self-leveling "Rock Hard" (or equal) to achieve level and stable surface.

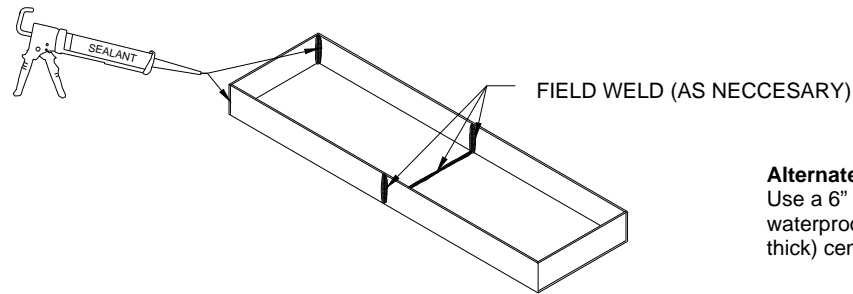


**Figure 1:**  
Use level to determine if the opening is plumb and level

### 3. Arche-Duct Installation

**Note:** Multiple piece Arche-Duct sections require field splicing.

- It is necessary to use an insulating material between the outer edge of the Arche-Duct and the rough opening. Direct contact with grout, concrete, or dissimilar metal can lead to corrosion of the Arche-Duct pan.
- Apply sealant in all corners and seams of the pan (Figure 2).



**Alternate Joining Method:**  
Use a 6" piece of adhesive waterproof material (max 1/16" thick) centered on the joint.

**Figure 2:**  
Seal corners and seams

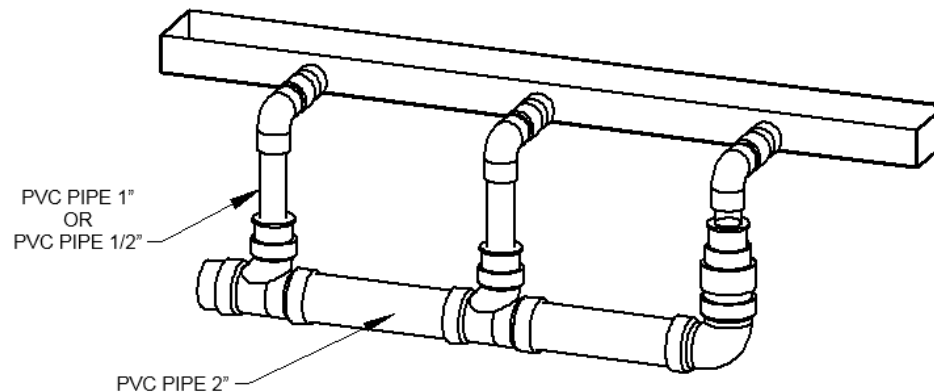
### 4. Arche-Duct Water Test

**Note:** Installer responsible for verifying the integrity of the Arche-Duct for water leakage and performance.

- Block all drain outlets and fill the Arche-Duct with water to verify the integrity of all seams and drain connections. Look for leak points, the water level of the Arche-Duct should remain constant. If the Arche-Duct passes water test, drain Arche-Duct and continue with installation of frame.

### 5. Arche-Duct Install

- Confirm proper orientation of Arche-Duct for tracks and drain location with customer order and/or dealer drawings.
- Install Arche-Duct into already leveled opening. An insulating material should be placed between the Arche-Duct and the supporting structure (concrete, steel, etc.) to prevent corrosion of the aluminum Arche-Duct.
- Connect tubing or pipe to Arche-Duct drain connections.



**Figure 3:**  
Drain Pipes Connected (side drains shown)

## 6. Confirm Weeping Slots

- Weep slot locations should be 8" from the ends and less than 60" (equally spaced) for proper drainage.

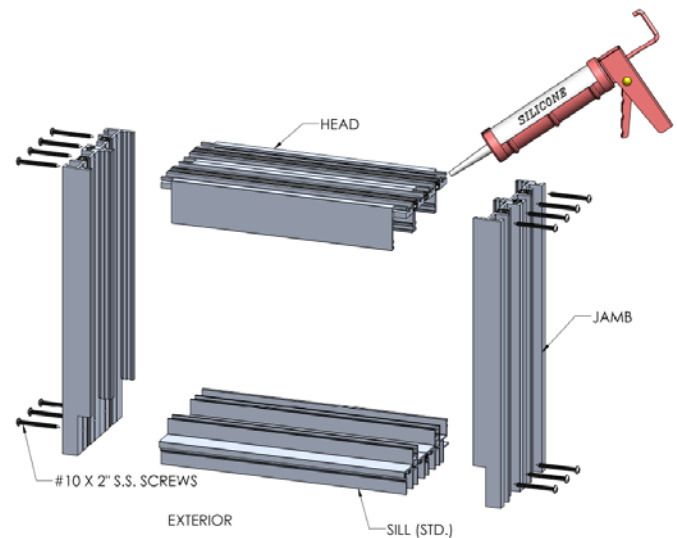
## 7. Backfill

- Do not back-fill until door operation is fully tested, including locking into jamb(s) and locking into pocket interlocker (when applicable).
- Verify you have access to drainage connections and clean out as necessary.

## V. Frame Assembly

**Note:** Due to the potential disruption during handling and installation, the installer is responsible for the integrity of all areas requiring sealant whether or not these frames were factory assembled.

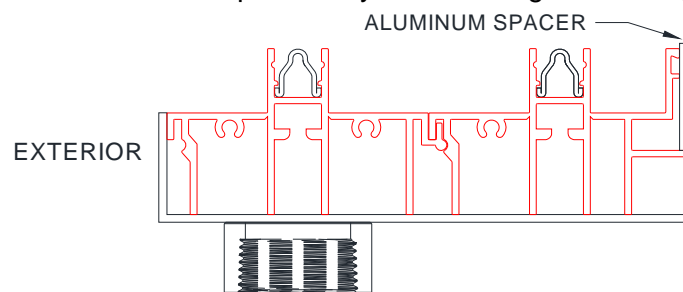
1. Check with customer order and/or dealer drawings to ensure left and right jamb orientation. Note the sill weep channel is to the interior.
2. Remove all pre-installed screws from head and sill.
3. Add sealant to the upper corners of the jamb(s) and to the end of the head that is compatible to the entire assembly as shown in Figure 4.
4. Attach the jamb(s) to the head using #10 x 2" long pan head screws. Check that the screws pass through jamb(s) and into the screw raceways in the head. It is recommended to add wax to the threads of all fasteners to reduce the drive torque.
5. Attach the jamb(s) to the sill using #10 x 2" long pan head screws. Check that the screws pass through jamb(s) and into the screw raceways in the sill. It is recommended to add wax to the threads of all fasteners to reduce the drive torque.



**Figure 4:**  
Frame Joint Sealing (2 tracks shown)

## VI. Frame Installation

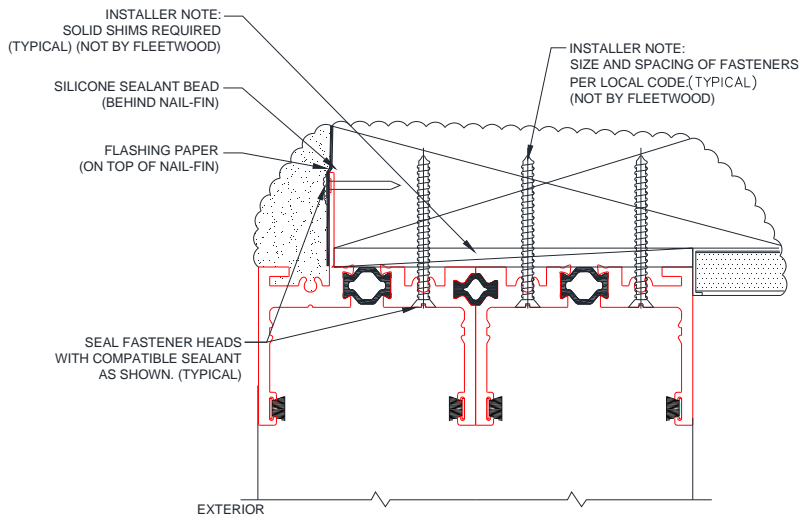
1. Place sill in Arche-Duct as shown in Figure 5.
2. Cut to length and insert aluminum spacer into weep channel along the full width of the frame. This will help protect from debris buildup that may occur during the flooring process.



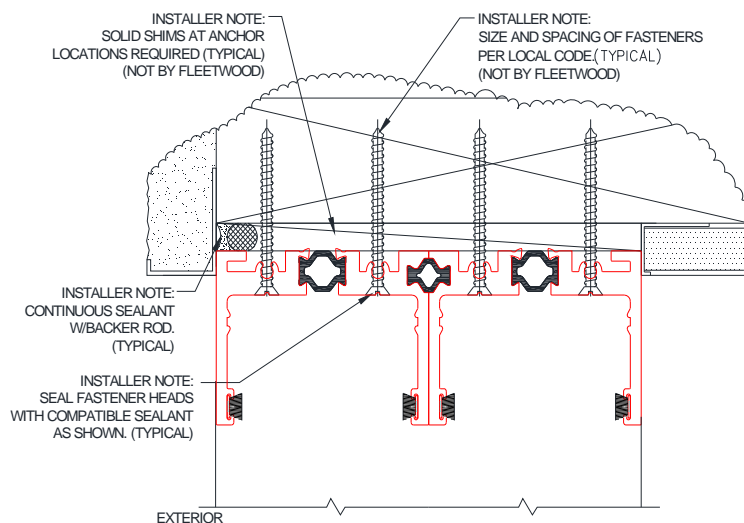
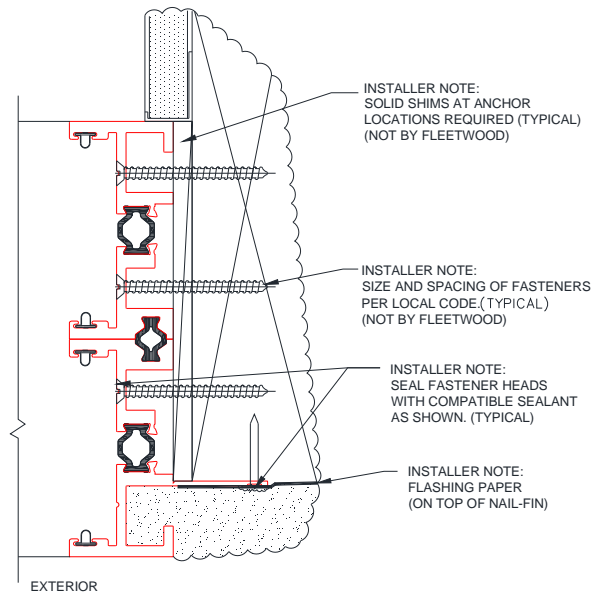
**Figure 5:**  
Sill Placement (2 tracks shown)

- Pre-fit the frame into the opening (*ensuring orientation is correct*). Confirm that the frame is centered and square, sill is level and jambs are plumb. Once you have confirmed the fit, attach frame to structure as shown below (Figures 6 & 7).

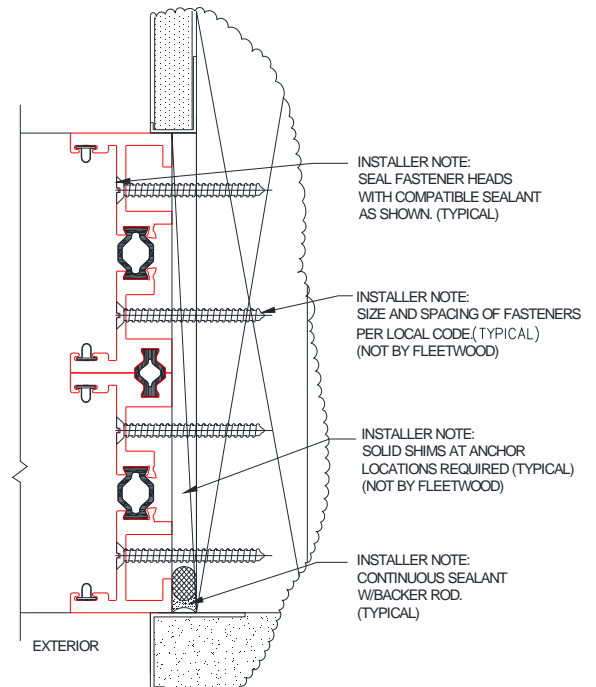
**Note:** Blocking, stainless steel screws (recommended), and wall finish not furnished by Fleetwood. Frame installation anchors furnished by installer. Fleetwood recommends countersink of all anchor screws.



**Figure 6:**  
Typical Nail-Fin Frame Installation  
(Head shown on the left, Jamb shown on the right)



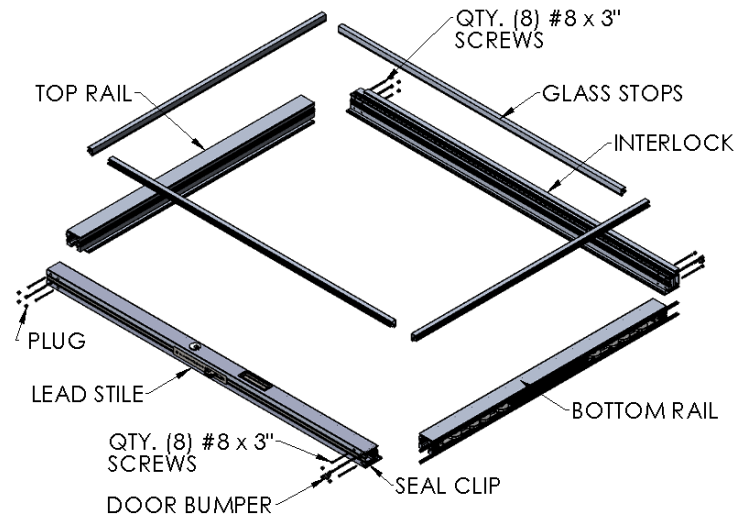
**Figure 7:**  
Typical Block Frame Installation  
(Head shown on the left, Jamb shown on the right)



## VII. Panel Assembly (when panels received unassembled)

**Note:** Make sure to keep individual panel components together. Match door configuration and panel orientation with customer order and/or dealer drawings. Configuration and orientation of panels shown in assembly instructions is for illustration purposes only.

- Check the red bag for keys, plugs, and door bumpers.
- Remove glass stops from panel components. Must be field cut to fit once panel is assembled.
- Remove all pre-installed screws from top and bottom rails.
- On the top and bottom rail cut the bulb vinyl a 1/4" long on both ends. Cut the bulb vinyl on the vertical stiles to length with the inner edge of the top and bottom rails.
- Apply sealant to the top and bottom rail where they make contact with the vertical stiles. Place the vertical stiles up against the top and bottom rail.



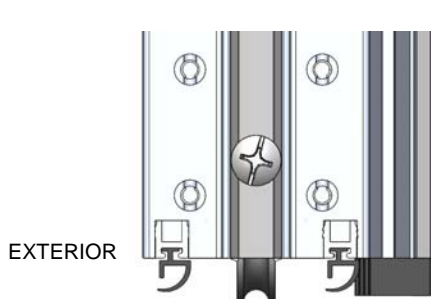
**Figure 8:**  
Panel Assembly (locking panel shown)

**Note:** For 90° Corner Doors remove the Stainless-Steel plates at top and bottom prior to top/bottom rail installation. After rails have been attached reattach Stainless Steel Plates.

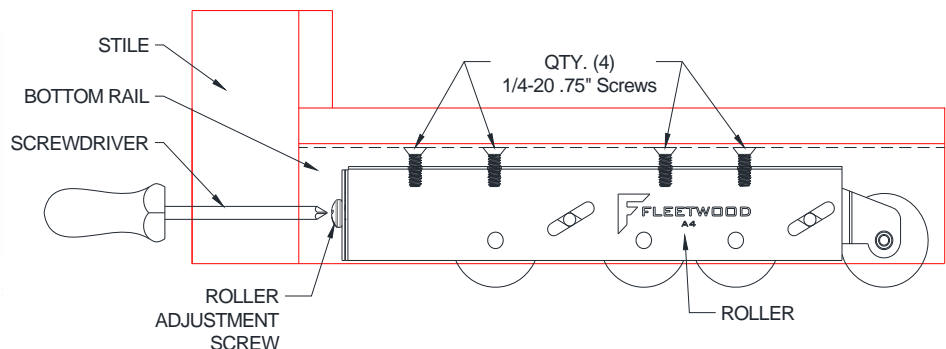
- Fasten the stiles to the rails with #8x3" flat head screws (8 per side), repeat for opposite side (Figure 8). It is recommended that wax is used on all fasteners to reduce the drive torque. Ensure the Roller adjustment holes and rollers align (Figure 9). Place the plugs over screw holes.
- Cut the Q-Lon in the bottom rail flush to the vertical stiles and secure using the clips provided (Figure 9).

**Note:** Do not cut the interlocker vinyl (to be trimmed in section IX).

- Adjust the rollers to the full up (into the extrusion) position using the adjustment screw (Figure 10). Before adjusting rollers, lift panels to relieve weight. Add plugs to panel when finished adjusting rollers.



**Figure 9:**  
Q-Lon Alignment



**Figure 10:**  
Roller Adjustment



### VIII. Glazing Instructions

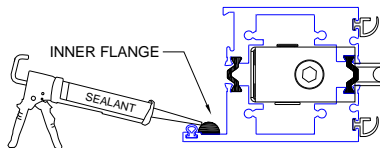
**Note:** When glazing Fleetwood recommends the use of a hydraulic glass lifter.

1. If glazing after panel installation (Figure 11), see Section VIII Panel Installation.
2. Remove precut glass stops from the panel, making sure to note the location from which each has been removed.
3. Check the red bag for the setting blocks.

#### 4a. Dry Glazed

- Apply a 1/4"×1/4"×6" bead of compatible sealant from each corner on inner flange of panel (Figure 12).
- Install 4"×1/8"×1" glass setting blocks located in red bag (10 per panel) at 1/4 points into stiles, top and bottom rails. To properly support insulated glass panes, stagger the setting blocks at bottom (Figure 13).
- Install glass to rest on the inner flange of panel then install glass stops (Figure 13). For instructions on squaring the panels see Appendix C.

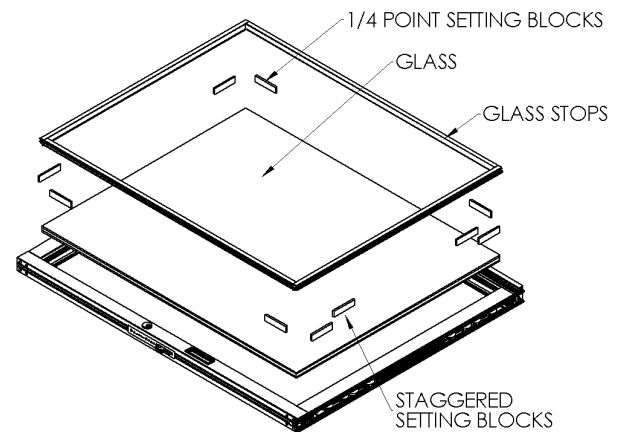
**Note:** For panel heights over 8 feet tall Fleetwood recommends an additional 24" of compatible sealant be applied halfway up on the vertical stiles.



**Figure 12:**  
Sealant location (bottom rail shown)



**Figure 11:**  
Glass Installation (after panel installation shown)

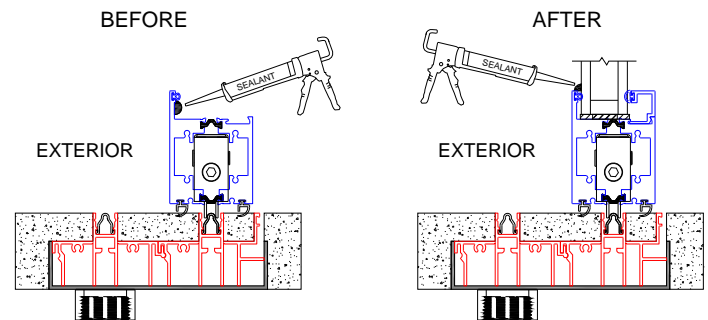


**Figure 13:**  
Glass Installation (horizontal installation shown)

#### 4b. Alternate Glazing Procedure

**Note:** Applies to inside glazed or outside glazed where additional water sealant is required.

- Apply a continuous 1/4"×1/4" bead of sealant before glazing. (Figure 14).
- Install 4"×1/8"×1" glass setting blocks located in red bag (10 per panel) at 1/4 points into stiles, top and bottom rails. To properly support insulated glass panes, stagger the setting blocks at bottom (Figure 13).
- Install glass to rest on the inner flange of panel (Figure 12) then install glass stops (Figure 13).
- Apply a bead of compatible sealant along the glass and glass stop edge.



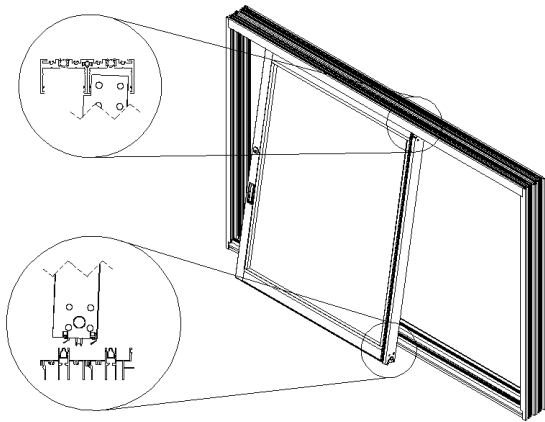
**Figure 14:**  
Inside Glazing Sealant Locations



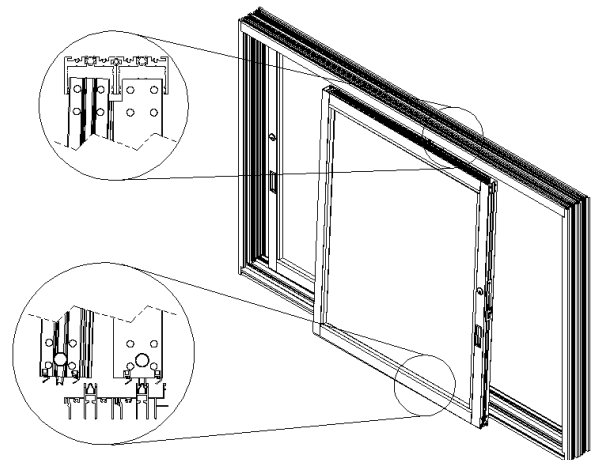
## IX. Panel Installation

**Note:** Check customer order and/or dealer drawings for proper panel configuration and orientation. Panels may be installed prior to glazing.

1. From the outside, with the weather-strip facing outside, insert the “X” panel into the furthest channel of the head. Push up and swing the bottom of the panel in (Figure 15) and down onto the sill. Ensure the rollers are correctly seated on the stainless-steel track.
2. Repeat for remaining panels ensuring the panels interlock properly (Figure 16).
3. After flooring has been installed, adjust rollers so that the bottom rail Q-Lon firmly contacts sill. Cut the interlocker vinyl so that an air barrier is formed with the flooring.
4. Adjust strike plate(s) to lock securely.



**Figure 15:**  
Initial Panel Installation

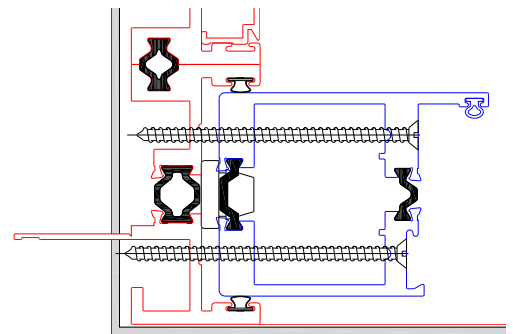


**Figure 16:**  
Sequential Panel Installation

### “O” Panel Installation

**Note:** Check customer order and/or dealer drawings for proper panel configuration and orientation. “O” Panels must be installed prior to glazing.

1. Lift and move the panel into the fixed jamb as far as possible.
2. Verify that the weather stripping in the frame head is located so that it contacts the width of the “O” panel. To properly adjust rollers, see Figure 10.
3. Using the pre-drilled holes as a guide, located in the stile, drill into the jamb with a 1/8” diameter drill bit.
4. Attach screws through the lead stile into the jamb (Figure 17).



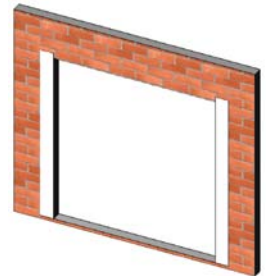
**Figure 17:**  
“O” Panel Installation

## X. Flashing after Installation

The flashing paper referred to in this document is Moistop or other code compliant flashing material that conforms to **Federal Specification UU-B-790a, Type 1, Grade A, Style 4**. The strips of flashing paper are to be no less than 9 inches wide (or wider as required by local codes). Flashing paper must be applied with galvanized nails or corrosion resistant staples. Flashing paper shall be applied in a weatherboard fashion around the full perimeter of the framed opening.

1. Once satisfied that the frame is water tight, and immediately prior to application of the flashing paper at the head and jambs, apply a continuous bead of sealant to the exposed mounting flange (nail-fin) at the top (head) and sides (jambs) of the installed frame. Also, apply sealant at corners of the frame, the full length of the seams where the nail fin flashing is mounted.
2. At each jamb, embed the flashing paper into the sealant onto mounting flange and fasten into place. The flashing paper should be cut sufficiently long enough to extend at least 3 in. past the weep-screed or diado flashing and at least 6 inches above the head of the window (Figure 18).
3. Finally, at the head, embed the flashing into the sealant on the mounting flange and fasten into place. The flashing paper should be cut sufficiently long enough to extend past the flashing paper at each jamb by at least 3 in (Figure 19).
4. Weather resistant building paper should be applied in a weatherboard fashion to complete the installation (Figure 20).

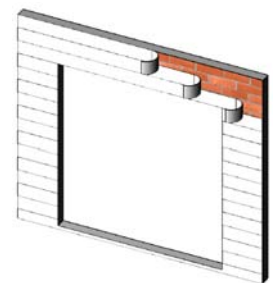
**Note:** Where weather resistant building paper, insulating board, or other materials by other trades may constitute the primary weather barrier behind the exterior wall finish (i.e. stucco, masonry, siding, etc.), the owner / General Contractor are responsible to ensure that the weather barrier is continuous by effectively sealing the material to the window frame.



**Figure 18:**  
Jamb flashing



**Figure 19:**  
Head Flashing



**Figure 20:**  
Building Flashing

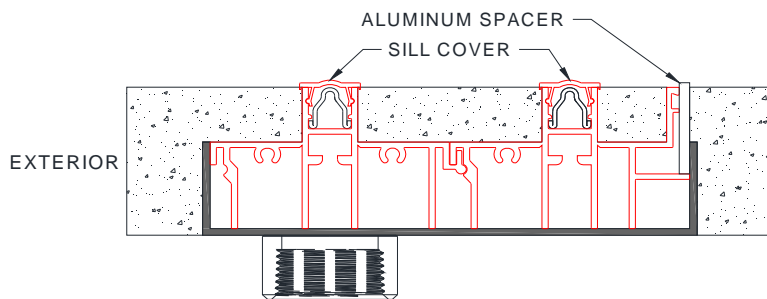
## XI. Finished Flooring Installation

**Flooring Material:** The sill for this product was designed to incorporate the finished flooring as a key component to the bottom rail sealing and the linear weep channel. The material chosen to surround the extruded sill should be such that water will not damage it.

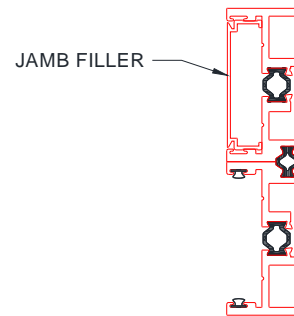
**Linear Weep Channel:** The sill comes with an aluminum spacer (Figure 21) to ensure the linear drain is correct.

**Construction & Installation Protection:** Included is an aluminum spacer and aluminum sill cover for each stainless steel track (Figure 21). Each extrusion should be removed and recycled after construction is completed.

**Jamb Filler Installation:** After the spacer and covers are removed, insert the jamb fillers from the bottom upward (Figure 22).

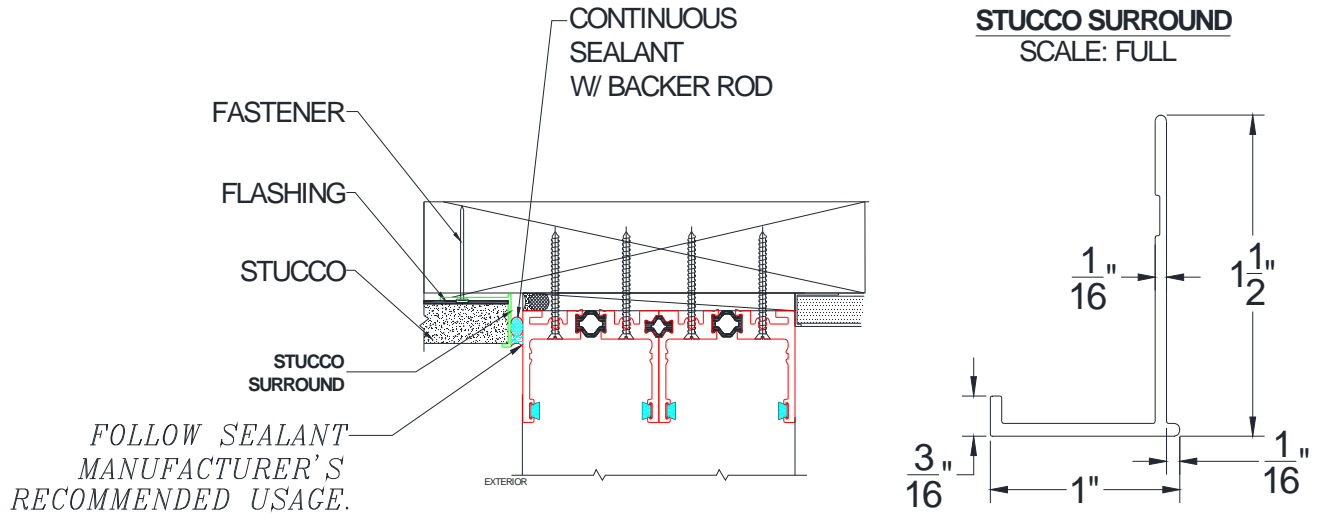


**Figure 21:**  
Flooring Installation (bottom drain shown)



**Figure 22:**  
Jamb Filler Installation (2 track shown)

**Appendix A: Stucco Surround Application (Optional)**

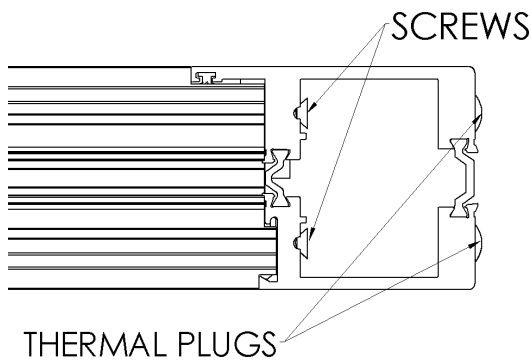


**Figure A1:**  
 Stucco Surround Detail and Extrusion

## Appendix B: Panel Squaring Instructions

**Tool Requirements:** screwdriver, pliers, tape measure, setting blocks, plate glass lifting tool.

1. Make sure the frame is squared before any adjustment to panel.
2. Lay panel on table and check distance of both diagonals. If they are not the same, the panel is not square.
3. Remove thermal plugs and loosen screws at 4 corners (Figure C1).
4. Use plate glass lifting tool and add additional shim(s) to the bottom of the panel on the side with the shorter diagonal measurement, between the glass and bottom rail. See Figure C2 on how to use the plate glass lifting tool.
5. Check diagonal distances, gap of panel to frame.
6. Tighten screws back into place and replace plugs.



**Figure B1:**  
Panel Screw Location (lock stile shown)



**Figure B2:**  
Plate Glass Lifter