

# ASSEMBLY / PARTS LIST (B.O.M.)

**Series: 3600-T**  
**Type: 4L1R and 1L4R Configuration**

TABLE OF CONTENTS			
ITEM NO.	DESCRIPTION	QTY.	PAGE #
1	Frame Assembly	1	2
2	Panel 1 Assembly	1	3-4
3	Panel 2 Assembly	1	5-6
4	Panel 3 Assembly	1	7-8
5	Panel 4 Assembly	1	9-10
6	Panel 5 Assembly	1	11-13

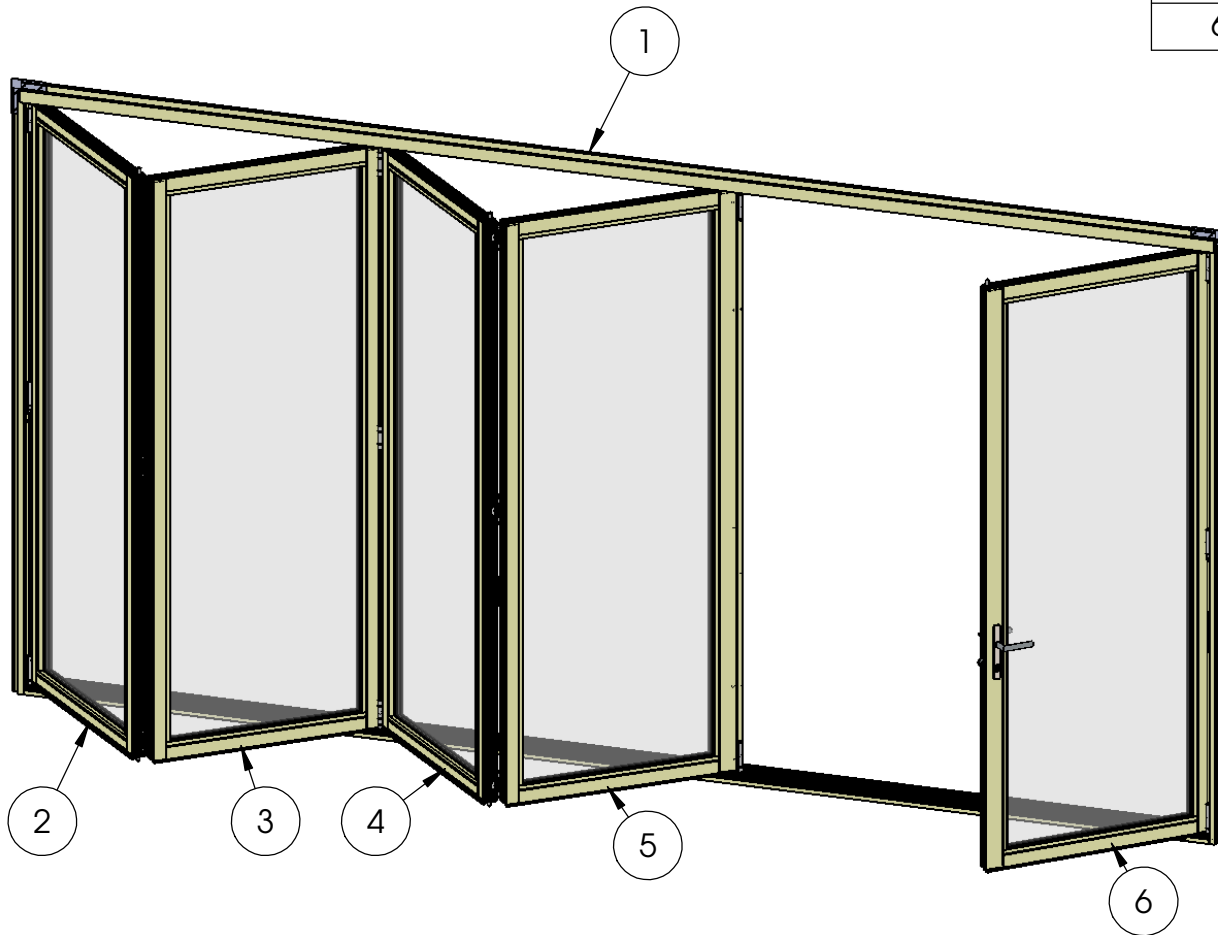

- NOTES:**
1. 4L1R Configuration shown
  2. Out-Swing Door shown
  3. Relative to the exterior numbering of panels is from left to right

**PROPRIETARY AND CONFIDENTIAL**  
THE INFORMATION CONTAINED IN THIS DRAWING IS THE SOLE PROPERTY OF FLEETWOOD WINDOWS & DOORS.  
ANY REPRODUCTION IN PART OR AS A WHOLE WITHOUT THE WRITTEN PERMISSION OF FLEETWOOD WINDOWS & DOORS IS PROHIBITED.

Description Table of Contents	
File Name Series 3600-T 4L1R and 1L4R Assembly	REV -
Released 5/9/2017	SHEET 1 OF 13

# ASSEMBLY / PARTS LIST (B.O.M.)

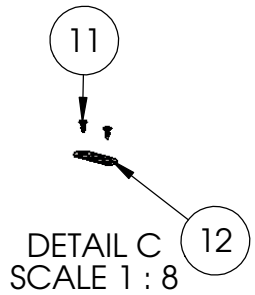
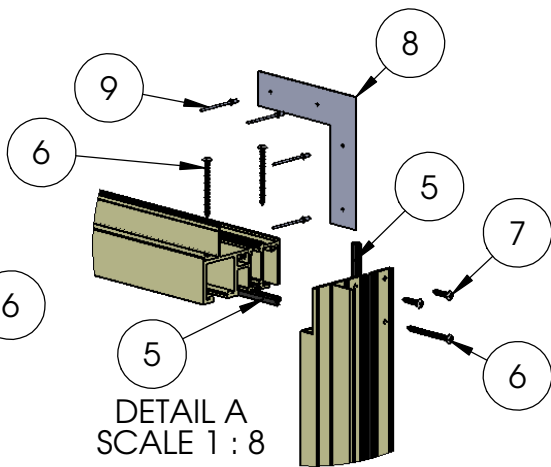
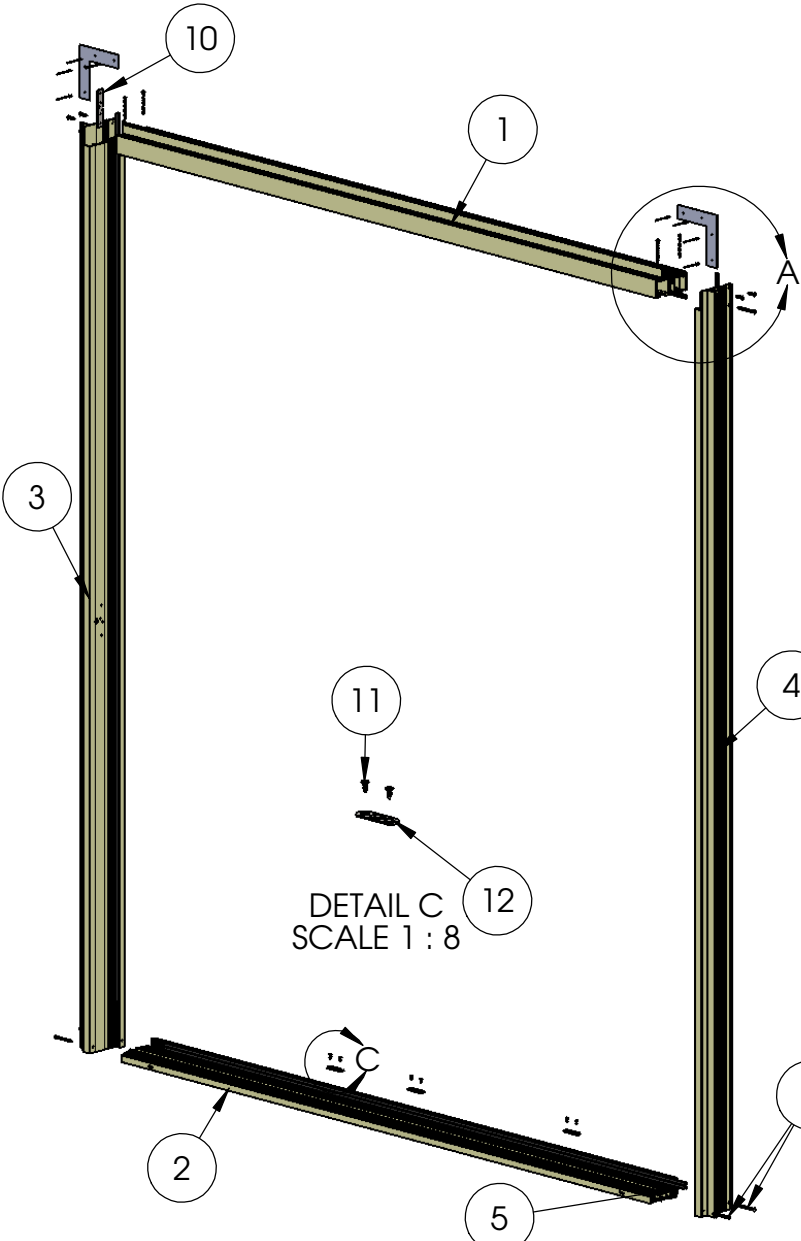

## EXTRUSIONS

ITEM NO.	PART NUMBER	DESCRIPTION	QTY.
1	3601	Head	1
2	3602	Sill	1
3	3603	Left Jamb	1
4	3603	Right Jamb	1

## HARDWARE

ITEM NO.	PART NUMBER	DESCRIPTION	QTY.
5	25059	Q-Lon Foam Seal	5
6	25075	# 10 PHP Screw, 2.5 In	10
7	20350	# 10 PHP Screw, 1 in.	4
8	18629	Nail-Fin Corner (For Nail-Fin Door)	2
9	25504	Pop Rivet	8
10	25585	Jamb Hinge Back Up Plate	1
11	20275	# 10 FHP-A-UC Screw, .5 in., Clear	6
12	25663	Shoot Bolt Strike Plate (part of a kit)	3

**PROPRIETARY AND CONFIDENTIAL**  
THE INFORMATION CONTAINED IN THIS DRAWING IS THE SOLE PROPERTY OF FLEETWOOD WINDOWS & DOORS.  
ANY REPRODUCTION IN PART OR AS A WHOLE WITHOUT THE WRITTEN PERMISSION OF FLEETWOOD WINDOWS & DOORS IS PROHIBITED.

Description Frame Assembly/B.O.M.	
File Name Series 3600-T 4L1R and 1L4R Assembly	REV -
Released 5/9/2017	SHEET 2 OF 13

# ASSEMBLY / PARTS LIST (B.O.M.)

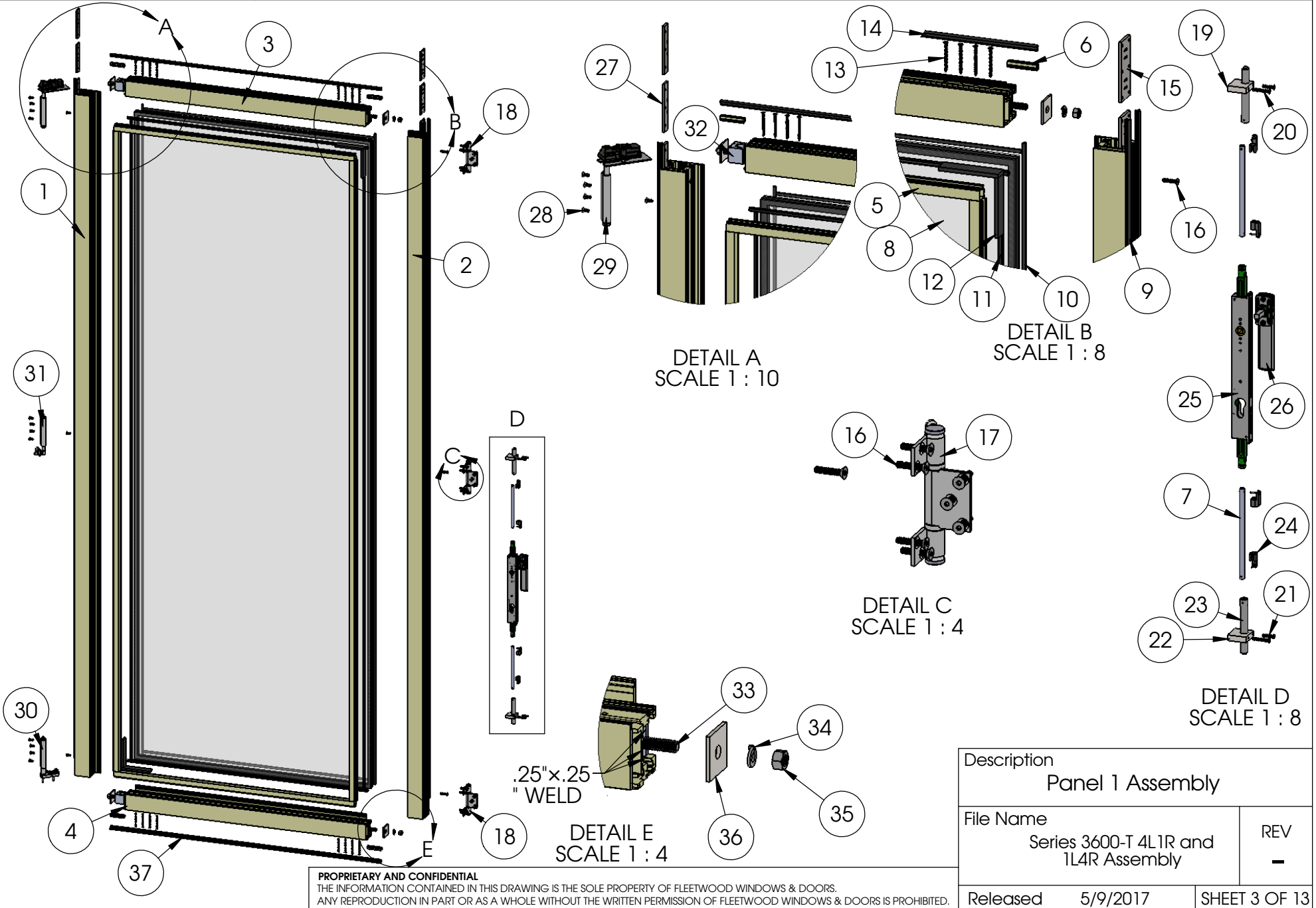

Description	
Panel 1 Assembly	
File Name	REV
Series 3600-T 4L1R and 1L4R Assembly	-
Released	SHEET 3 OF 13
5/9/2017	

**PROPRIETARY AND CONFIDENTIAL**  
THE INFORMATION CONTAINED IN THIS DRAWING IS THE SOLE PROPERTY OF FLEETWOOD WINDOWS & DOORS.  
ANY REPRODUCTION IN PART OR AS A WHOLE WITHOUT THE WRITTEN PERMISSION OF FLEETWOOD WINDOWS & DOORS IS PROHIBITED.

# ASSEMBLY / PARTS LIST (B.O.M.)

## Extrusions

ITEM NO.	PART NUMBER	DESCRIPTION	QTY.
1	3604	Left Stile	1
2	3604	Right Stile	1
3	3604	Top Rail	1
4	3604	Bottom Rail	1
5	3907	1" Glass Stop (Shown)	4
6	3916	Seal Clip	4
7	FW1203	Aluminum Rod	2

## Hardware

ITEM NO.	PART NUMBER	DESCRIPTION	QTY.
8	IG Glass	Glass	1
9	25059	Q-Lon Foam Seal	3
10	25199	Mini Bulb Vinyl	4
11	25031	Bulb Vinyl-Large	4
12	18620	Setting Block 4" x 1/4"x1"	4
13	20258	# 8 FHP Screw, 2"	16
14	25058	Q-Lon Foam Seal (at Head)	1
15	25586	Hinge Back Up Plate	3
16	25488, 25489	# 10-32 FH Torx Screw, 1", Clear, Black, Driver Size T25	24
17	25652,25653	Hinge Handle Offset Middle	1
18	25652,25653	Hinge Handle Offset Top and Bottom	2
19	25587	Top Shoot Bolt Guide	1
20	25343	# 8-32 FHP Screw, 1.125"	2
21	25760	# 8-32 FHP SCrew, .75"	2
22	25588	Bottom Shoot Bolt Guide	1
23	25663	Shoot Bolt Ends (part of a kit)	2
24	25663	Locking Pins (part of a kit)	4
25	25662	DPL Lock Body	1

## Hardware

ITEM NO.	PART NUMBER	DESCRIPTION	QTY.
26	25656,25657	DPL Non-Locking Handle	1
27	25582	Hinge Back Up Plate	3
28	25486, 25487	# 10-32 FH Torx Screw, 0.5", Clear, Black, Driver Size T25	15
29	25638,25639	Pivot Top (part of a set)	1
30	25638,25639	Pivot Bottom (part of a set)	1
31	25640,25641	Jamb Pivot	1
32	3906	Corner Block	4
33	25668	.375-16 Hex Head Cap Screw, 1.625"	4
34	25024	.375 Split Lock Washer	4
35	25023	.375-16 Stainless Steel Hex Nut	4
36	25573	Back up Plate Corner Block	4
37	25683	Foam Seal	1

Description

Panel 1 B.O.M.

File Name

Series 3600-T 4L1R and  
1L4R Assembly

REV

Released

5/9/2017

SHEET 4 OF 13

**PROPRIETARY AND CONFIDENTIAL**

THE INFORMATION CONTAINED IN THIS DRAWING IS THE SOLE PROPERTY OF FLEETWOOD WINDOWS & DOORS.  
ANY REPRODUCTION IN PART OR AS A WHOLE WITHOUT THE WRITTEN PERMISSION OF FLEETWOOD WINDOWS & DOORS IS PROHIBITED.

# ASSEMBLY / PARTS LIST (B.O.M.)

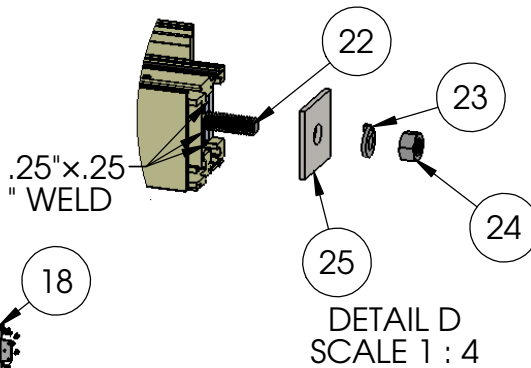
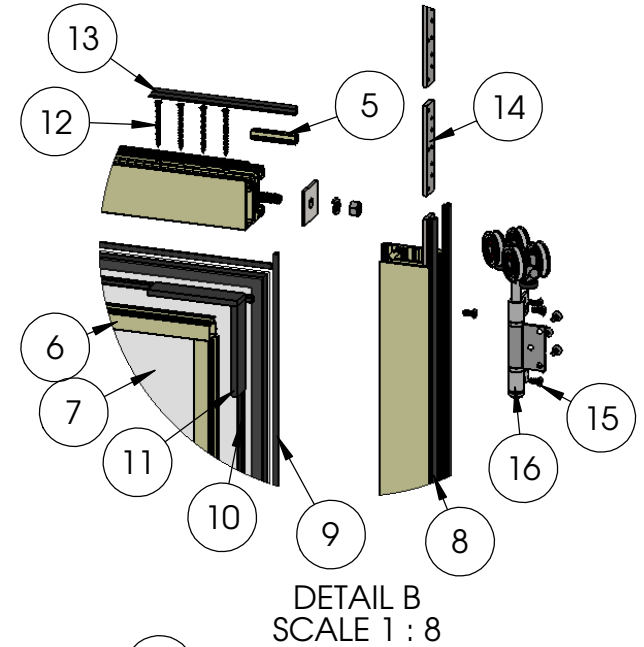
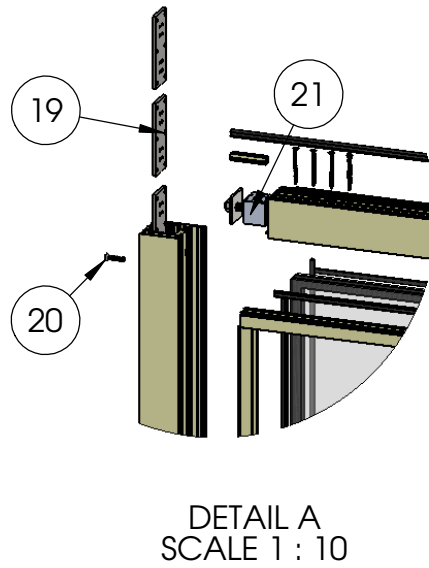
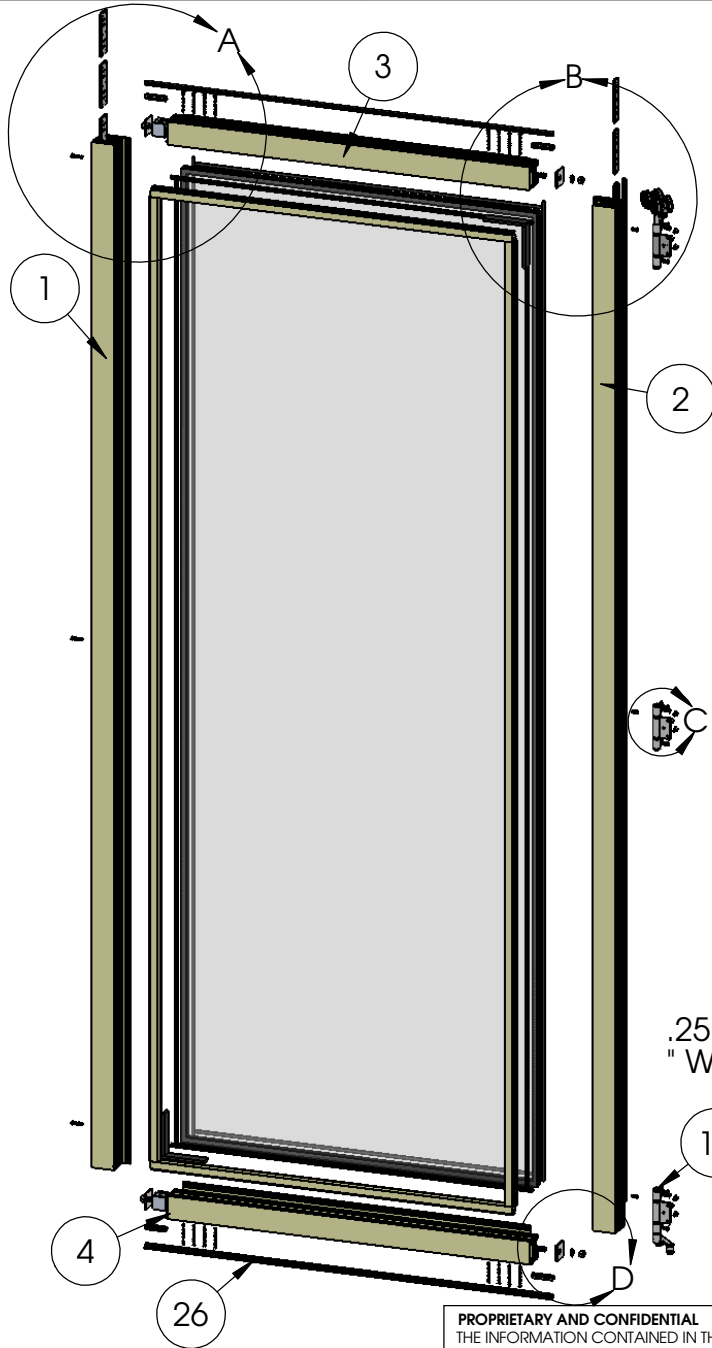

PROPRIETARY AND CONFIDENTIAL  
THE INFORMATION CONTAINED IN THIS DRAWING IS THE SOLE PROPERTY OF FLEETWOOD WINDOWS & DOORS.  
ANY REPRODUCTION IN PART OR AS A WHOLE WITHOUT THE WRITTEN PERMISSION OF FLEETWOOD WINDOWS & DOORS IS PROHIBITED.

Description Panel 2 Assembly	
File Name Series 3600-T 4L1R and 1L4R Assembly	REV -
Released 5/9/2017	SHEET 5 OF 13

# ASSEMBLY / PARTS LIST (B.O.M.)

Extrusions			
ITEM NO.	PART NUMBER	DESCRIPTION	QTY.
1	3604	Left Stile	1
2	3604	Right Stile	1
3	3604	Top Rail	1
4	3604	Bottom Rail	1
5	3916	Seal Clip	4
6	3907	1" Glass Stop (Shown)	4
Hardware			
ITEM NO.	PART NUMBER	DESCRIPTION	QTY.
7	IG Glass	Glass	1
8	25059	Q-Lon Foam Seal	2
9	25199	Mini Bulb Vinyl	4
10	25031	Bulb Vinyl-Large	4
11	18620	Setting Block	4
12	20258	# 8 FHP Screw, 2"	16
13	25058	Q-Lon Foam Seal (at Head)	1
14	25584	Hinge Back Up Plate Intermediate Carrier	3
15	25486, 25487	# 10-32 FH Torx Screw, 0.5", Clear, Black, Driver Size T25	24
16	25644	Intermediate Hanger (part of a set)	1
17	25646,25647	Intermediate Hanger Middle (part of a set)	1
18	25644	Intermediate Guide (part of a set)	1

Hardware			
ITEM NO.	PART NUMBER	DESCRIPTION	QTY.
19	25586	Hinge Back Up Plate	3
20	25488, 25489	# 10-32 FH Torx Screw, 1", Clear, Black, Driver Size T25	3
21	3906	Corner Block	4
22	25668	.375-16 Hex Head Cap Screw, 1.625"	4
23	25024	.375 Split Lock Washer	4
24	25023	.375-16 Stainless Steel Hex Nut	4
25	25573	Back up Plate Corner Block	4
26	25683	Foam Seal	1
27	25199	Mini Bulb Vinyl	2
28	25031	Bulb Vinyl Large	2
29	3907	1" Glass Stop (Shown)	2

Description Panel 2 B.O.M.	
File Name Series 3600-T 4L1R and 1L4R Assembly	REV
Released 5/9/2017	SHEET 6 OF 13

# ASSEMBLY / PARTS LIST (B.O.M.)

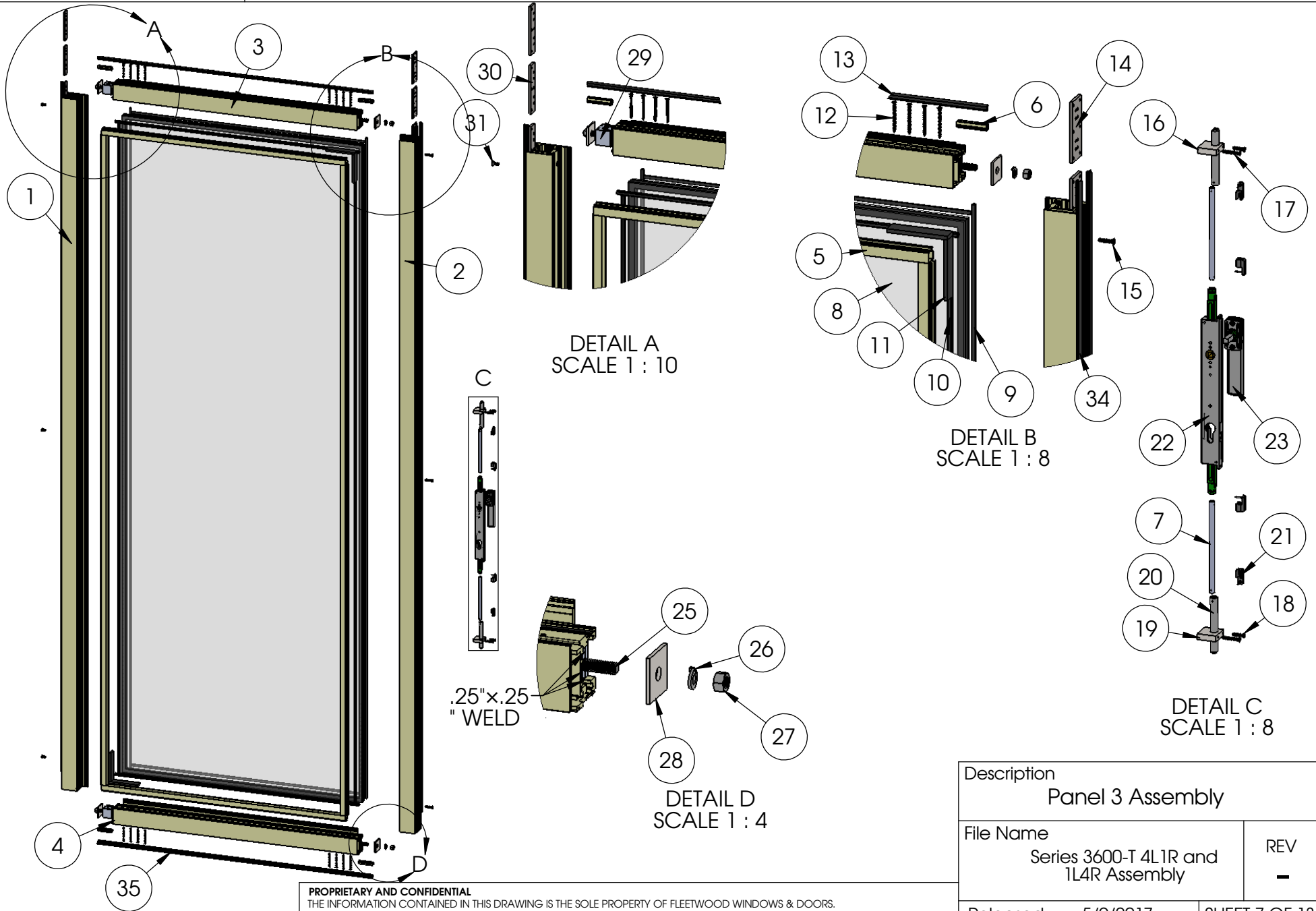

**PROPRIETARY AND CONFIDENTIAL**  
THE INFORMATION CONTAINED IN THIS DRAWING IS THE SOLE PROPERTY OF FLEETWOOD WINDOWS & DOORS.  
ANY REPRODUCTION IN PART OR AS A WHOLE WITHOUT THE WRITTEN PERMISSION OF FLEETWOOD WINDOWS & DOORS IS PROHIBITED.

Description Panel 3 Assembly	
File Name Series 3600-T 4L1R and 1L4R Assembly	REV -
Released 5/9/2017	SHEET 7 OF 13

# ASSEMBLY / PARTS LIST (B.O.M.)

## Extrusions

ITEM NO.	PART NUMBER	DESCRIPTION	QTY.
1	3604	Left Stile	1
2	3604	Right Stile	1
3	3604	Top Rail	1
4	3604	Bottom Rail	1
5	3907	1" Glass Stop (Shown)	2
6	3916	Seal Clip	4
7	FW1203	Aluminum Rod	2

## Hardware

ITEM NO.	PART NUMBER	DESCRIPTION	QTY.
8	IG Glass	Glass	1
9	25199	Mini Bulb Vinyl	4
10	25031	Bulb Vinyl-Large	4
11	18620	Setting Block	4
12	20258	# 8 FHP Screw, 2"	16
13	25058	Q-Lon Foam Seal (at Head)	1
14	25586	Hinge Back Up Plate	3
15	25488, 25489	# 10-32 FH Torx Screw, 1", Clear, Black, Driver Size T25	3
16	25587	Top Shoot Bolt Guide	1
17	25343	# 8-32 FHP Screw, 1.125"	2
18	25760	# 8-32 FHP SCrew, .75"	2
19	25588	Bottom Shoot Bolt Guide	1
20	25663	Shoot Bolt Ends (part of a kit)	2
21	25663	Locking Pins (part of a kit)	4
22	25662	DPL Lock Body	1
23	25656,25657	DPL Non-Locking Handle	1
24	3907	1" Glass Stop (Shown)	2
25	25668	.375-16 Hex Head Cap Screw, 1.625"	4
26	25024	.375 Split Lock Washer	4
27	25023	.375-16 Stainless Steel Hex Nut	4
28	25573	Back up Plate Corner Block	4

## Hardware

ITEM NO.	PART NUMBER	DESCRIPTION	QTY.
29	3906	Corner Block	4
30	25584	Hinge Back Up Plate Intermediate Carrier	3
31	25486, 25487	# 10-32 FH Torx Screw, 0.5", Clear, Black, Driver Size T25	3
32	25199	Mini Bulb Vinyl	2
33	25031	Bulb Vinyl Large	2
34	25059	Q-Lon Foam Seal	3
35	25683	Foam Seal	1

Description

Panel 3 B.O.M.

File Name

Series 3600-T 4L1R and  
1L4R Assembly

REV

-

**PROPRIETARY AND CONFIDENTIAL**

THE INFORMATION CONTAINED IN THIS DRAWING IS THE SOLE PROPERTY OF FLEETWOOD WINDOWS & DOORS.  
ANY REPRODUCTION IN PART OR AS A WHOLE WITHOUT THE WRITTEN PERMISSION OF FLEETWOOD WINDOWS & DOORS IS PROHIBITED.

Released 5/9/2017

SHEET 8 OF 13



# ASSEMBLY / PARTS LIST (B.O.M.)

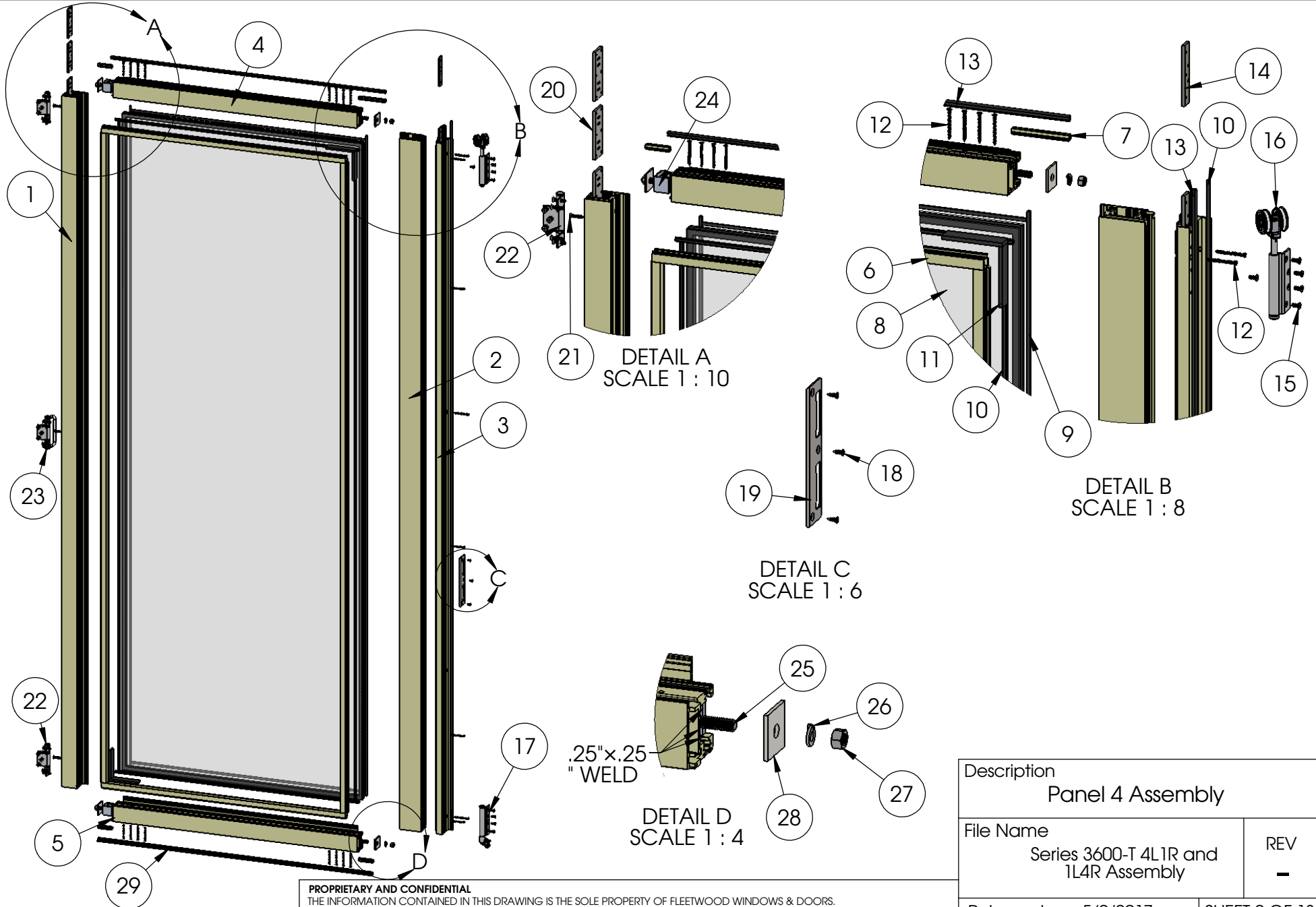

**PROPRIETARY AND CONFIDENTIAL**  
THE INFORMATION CONTAINED IN THIS DRAWING IS THE SOLE PROPERTY OF FLEETWOOD WINDOWS & DOORS.  
ANY REPRODUCTION IN PART OR AS A WHOLE WITHOUT THE WRITTEN PERMISSION OF FLEETWOOD WINDOWS & DOORS IS PROHIBITED.

Description Panel 4 Assembly	
File Name Series 3600-T 4L1R and 1L4R Assembly	REV -
Released	5/9/2017
SHEET 9 OF 13	

# ASSEMBLY / PARTS LIST (B.O.M.)

## Extrusions

ITEM NO.	PART NUMBER	DESCRIPTION	QTY.
1	3604	Left Stile	1
2	3205	Lock Stile	1
3	3206	Astragal	1
4	3604	Top Rail	1
5	3604	Bottom Rail	1
6	3907	1" Glass Stop (Shown)	4
7	3916	Seal Clip	4

## Hardware

ITEM NO.	PART NUMBER	DESCRIPTION	QTY.
8	IG Glass	Glass	1
9	25199	Mini Bulb Vinyl	5
10	25031	Bulb Vinyl-Large	4
11	18620	Setting Block 4" x 1/4"x1"	4
12	20258	# 8 FHP Screw, 2"	24
13	25058	Q-Lon Foam Seal (at Head)	1
14	25582	Hinge Back Up Plate	2
15	25486, 25487	# 10-32 FH Torx Screw, 0.5", Clear, Black, Driver Size T25	10
16	25642,25643	End Hanger Top	1
17	25642,25643	End Hanger Bottom	1
18	20240	# 8 FHP-A-UC, 1/2", Clear	3
19	24993	Latch-Deadbolt Strike Plate	1
20	25586	Hinge Back Up Plate	3
21	25488, 25489	# 10-32 FH Torx Screw, 1", Clear, Black, Driver Size T25	24
22	25652,25653	Hinge Handle Offset	2
23	25652,25653	Hinge Handle Offset middle	1
24	3906	Corner Block	4
25	25668	.375-16 Hex Head Cap Screw, 1.625"	4

## Hardware

ITEM NO.	PART NUMBER	DESCRIPTION	QTY.
26	25024	.375 Split Lock Washer	4
27	25023	.375-16 Stainless Steel Hex Nut	4
28	25573	Back up Plate Corner Block	4
29	25683	Foam Seal	1

Description

Panel 4 B.O.M.

File Name

Series 3600-T 4L1R and  
1L4R Assembly

REV

-

**PROPRIETARY AND CONFIDENTIAL**

THE INFORMATION CONTAINED IN THIS DRAWING IS THE SOLE PROPERTY OF FLEETWOOD WINDOWS & DOORS.  
ANY REPRODUCTION IN PART OR AS A WHOLE WITHOUT THE WRITTEN PERMISSION OF FLEETWOOD WINDOWS & DOORS IS PROHIBITED.

Released 5/9/2017

SHEET 10 OF 13

# ASSEMBLY / PARTS LIST (B.O.M.)

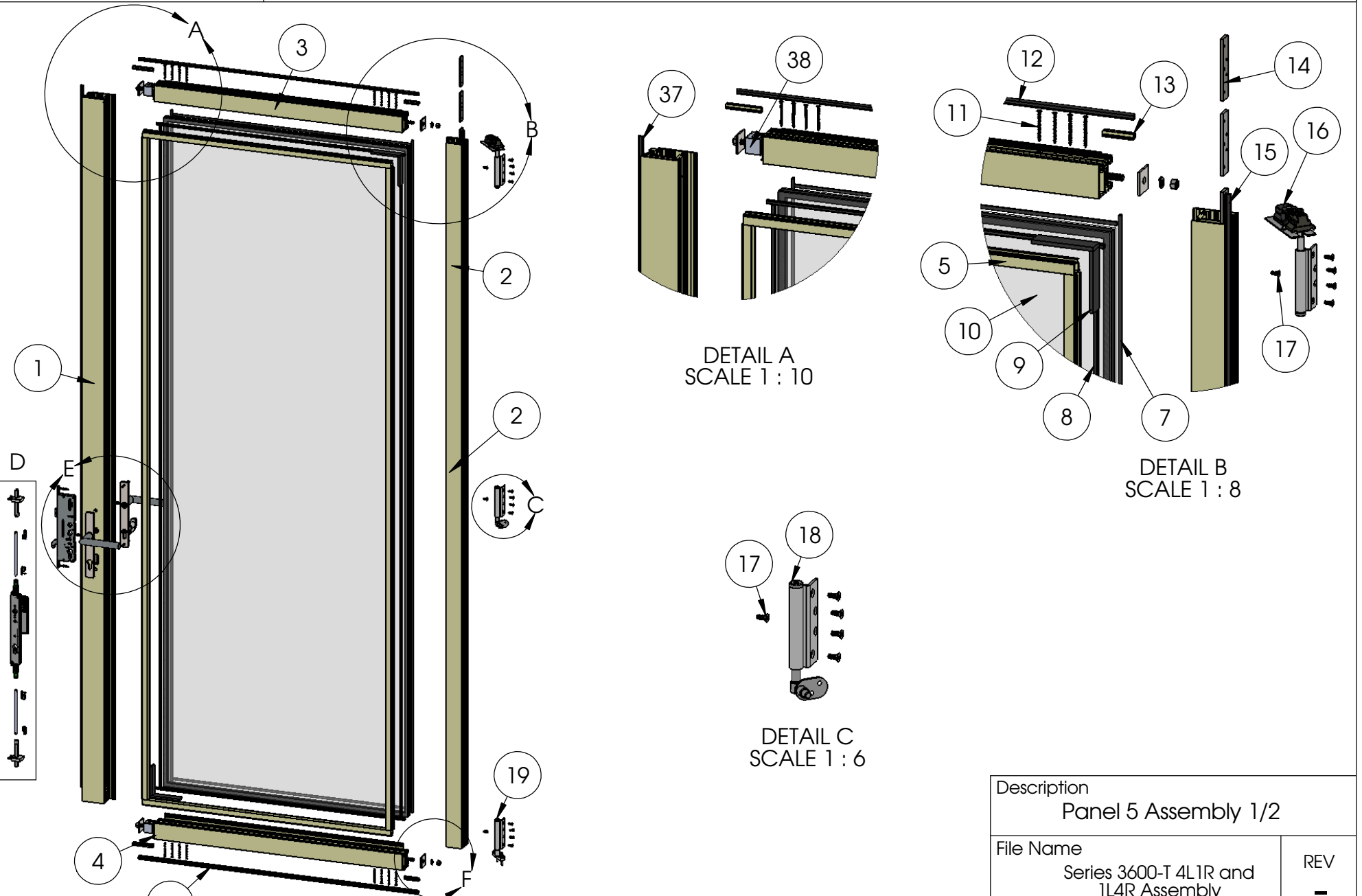

**PROPRIETARY AND CONFIDENTIAL**  
THE INFORMATION CONTAINED IN THIS DRAWING IS THE SOLE PROPERTY OF FLEETWOOD WINDOWS & DOORS.  
ANY REPRODUCTION IN PART OR AS A WHOLE WITHOUT THE WRITTEN PERMISSION OF FLEETWOOD WINDOWS & DOORS IS PROHIBITED.

Description Panel 5 Assembly 1/2	
File Name Series 3600-T 4L1R and 1L4R Assembly	REV -
Released 5/9/2017	SHEET 11 OF 13

# ASSEMBLY / PARTS LIST (B.O.M.)

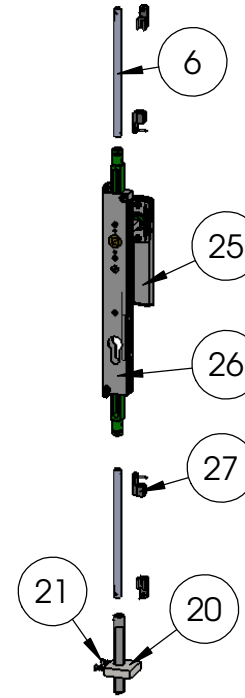
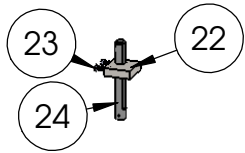

DETAIL D  
 SCALE 2 : 17

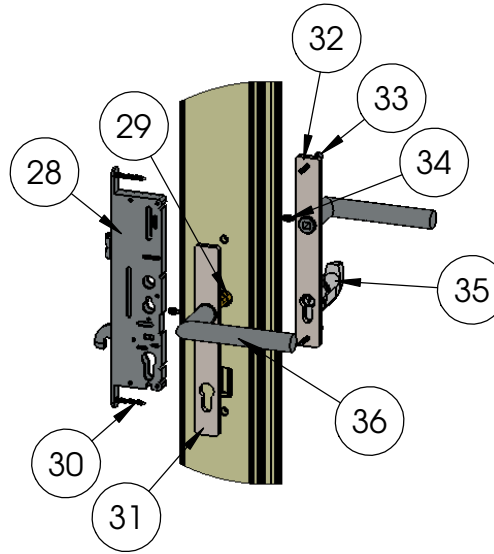

DETAIL E  
 SCALE 2 : 17

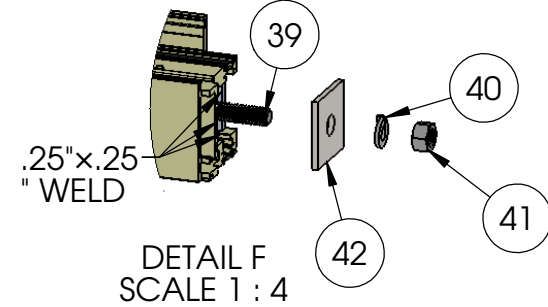

**PROPRIETARY AND CONFIDENTIAL**  
 THE INFORMATION CONTAINED IN THIS DRAWING IS THE SOLE PROPERTY OF FLEETWOOD WINDOWS & DOORS.  
 ANY REPRODUCTION IN PART OR AS A WHOLE WITHOUT THE WRITTEN PERMISSION OF FLEETWOOD WINDOWS & DOORS IS PROHIBITED.

Description Panel 5 Assembly 2/2	
File Name Series 3600-T 4L1R and 1L4R Assembly	REV -
Released 5/9/2017	SHEET 12 OF 13

# ASSEMBLY / PARTS LIST (B.O.M.)

## Extrusions

ITEM NO.	PART NUMBER	DESCRIPTION	QTY.
1	3205	Sash - Lock Stile	1
2	3604	Right Stile	1
3	3604	Top Rail	1
4	3604	Bottom Rail	1
5	3907	1" Glass Stop (Shown)	2
6	FW1203	Aluminum Rod	2

## Hardware

ITEM NO.	PART NUMBER	DESCRIPTION	QTY.
7	25199	Mini Bulb Vinyl	4
8	25031	Bulb Vinyl-Large	4
9	18620	Setting Block 4" x 1/4"x1"	4
10	IG Glass	Glass	1
11	20258	# 8 FHP Screw, 2"	16
12	25058	Q-Lon Foam Seal (at Head)	1
13	3916	Seal Clip	4
14	25582	Hinge Back Up Plate	3
15	25059	Q-Lon Foam Seal	1
16	25638,25639	Pivot Top (part of a set)	1
17	25486, 25487	# 10-32 FH Torx Screw, 0.5", Clear, Black, Driver Size T25	15
18	25640,25641	Jamb Pivot	1
19	25638,25639	Pivot Bottom (part of a set)	1
20	25588	Bottom Shoot Bolt Guide	1
21	25760	# 8-32 FHP SCrew, .75 in.	2
22	25587	Top Shoot Bolt Guide	1
23	25343	# 8-32 FHP Screw, 1.125 in	2
24	25663	Shoot Bolt Ends (part of a kit)	2
25	25656,25657	DPL Non-Locking Handle	1
26	25662	DPL Lock Body	1
27	25663	Locking Pins (part of a kit)	4
28	25758	Yale Latch	1

## Hardware

ITEM NO.	PART NUMBER	DESCRIPTION	QTY.
29	23203	Spindle	1
30	20252	Flat Head Phillips Sheet Metal Screw No 8 Size, 1.5"	2
31	25207	Escutcheon-Active,Exterior-1	1
32	25207	Escutcheon-Active, Interior-2	1
33	25342	# 10-32 FHP Screw, 2.25"	2
34	(Shipped with Handle)	Socket Set Screw .250-20, .375"	2
35	23204	FSB Cylinder for Active	1
36	23654	FSB_1076 Lever (Default)	2
37	25058	Q-Lon Foam Seal	1
38	3906	Corner Block	4
39	25668	.375-16 Hex Head Cap Screw, 1.625"	4
40	25024	.375 Split Lock Washer	4
41	25023	.375-16 Stainless Steel Hex Nut	4
42	25573	Back up Plate Corner Block	4
43	25683	Foam Seal	1

Description

Panel 5 B.O.M.

File Name

Series 3600-T 4L1R and  
1L4R Assembly

REV

-

**PROPRIETARY AND CONFIDENTIAL**

THE INFORMATION CONTAINED IN THIS DRAWING IS THE SOLE PROPERTY OF FLEETWOOD WINDOWS & DOORS.  
ANY REPRODUCTION IN PART OR AS A WHOLE WITHOUT THE WRITTEN PERMISSION OF FLEETWOOD WINDOWS & DOORS IS PROHIBITED.

Released 5/9/2017

SHEET 13 OF 13