

**TABLE OF CONTENTS**

<b>I. CARE AND MAINTENANCE</b> .....	<b>2</b>
<b>II. TOOLS / MATERIALS, SEALANT REQUIREMENTS, &amp; LOAD / ANCHOR INSTRUCTIONS</b> .....	<b>2</b>
<b>III. ASSEMBLY AND INSTALLATION</b> .....	<b>2</b>
<b>IV. STRUCTURE VERIFICATION &amp; SILLPAN INSTALLATION</b> .....	<b>3</b>
1. Opening Verification .....	3
2. Pre-Fit and Leveling.....	3
3. Sill-pan Installation .....	4
<b>V. GLAZING ASSEMBLY</b> .....	<b>4</b>
<b>VI. PANEL ASSEMBLY</b> .....	<b>5</b>
“X” Panel .....	5
“O” Panel .....	6
“O” Panel (non-interlocker) .....	6
<b>VII. FRAME ASSEMBLY</b> .....	<b>7</b>
<b>VIII. NAIL-FIN FRAME INSTALLATION</b> .....	<b>8</b>
<b>IX. BLOCK FRAME INSTALLATION</b> .....	<b>9</b>
<b>X. PANEL INSTALLATION</b> .....	<b>10</b>
<b>XI. ANTI-LIFT</b> .....	<b>11</b>
<b>XII. “O” PANELIZED INSTALLATION</b> .....	<b>11</b>
<b>XIII. SCREEN INSTALLATION</b> .....	<b>11</b>
<b>XIV. FLASHING AFTER INSTALLATION</b> .....	<b>12</b>

**TABLE OF CONTENTS**

<b>I. CARE AND MAINTENANCE</b> .....	<b>2</b>
<b>II. TOOLS / MATERIALS, SEALANT REQUIREMENTS, &amp; LOAD / ANCHOR INSTRUCTIONS</b> .....	<b>2</b>
<b>III. ASSEMBLY AND INSTALLATION</b> .....	<b>2</b>
<b>IV. STRUCTURE VERIFICATION &amp; SILLPAN INSTALLATION</b> .....	<b>3</b>
1. Opening Verification .....	3
2. Pre-Fit and Leveling.....	3
3. Sill-pan Installation .....	4
<b>V. GLAZING ASSEMBLY</b> .....	<b>4</b>
<b>VI. PANEL ASSEMBLY</b> .....	<b>5</b>
“X” Panel .....	5
“O” Panel.....	6
“O” Panel (non-interlocker).....	6
<b>VII. FRAME ASSEMBLY</b> .....	<b>7</b>
<b>VIII. NAIL-FIN FRAME INSTALLATION</b> .....	<b>8</b>
<b>IX. BLOCK FRAME INSTALLATION</b> .....	<b>9</b>
<b>X. PANEL INSTALLATION</b> .....	<b>10</b>
<b>XI. ANTI-LIFT</b> .....	<b>11</b>
<b>XII. “O” PANELIZED INSTALLATION</b> .....	<b>11</b>
<b>XIII. SCREEN INSTALLATION</b> .....	<b>11</b>
<b>XIV. FLASHING AFTER INSTALLATION</b> .....	<b>12</b>

## I. Care and Maintenance

**Operational Warning:** Fleetwood products operate smoothly and special care should be taken by the owner to make sure users are not injured.

This product is factory finished. Please handle with extreme care. Protect all exposed surfaces from contact with caustics, corrosives, solvents, abrasions, impacts, wet packing material etc.

**FAILURE TO DO SO WILL NULLIFY THE WARRANTY.** Before **ANY CLEANING**, review the Care & Maintenance Instructions (go to [www.fleetwoodusa.com](http://www.fleetwoodusa.com) for more information). **Contact the local dealer with any questions or concerns.** Fleetwood strongly recommends that all products be cleaned after installation and totally protected from construction debris and equipment.

## II. Tools / Materials, Sealant Requirements, & Load / Anchor Instructions

**Tools Required:** Tape measure, Soft mallet, Flat head screwdriver, level, Shims, Nails, Screws, Sealant, caulk gun, Backer Rod, Scissors or utility knife, drill bit, drive bit and powered drill.

### Sealant Requirements

- The sealant referred to within this document for seals associated with the assembly of the product should conform to **AAMA 800**. It is recommended that all other sealants conform to **AAMA 800** but may be a sealant recommended and approved by the sealant manufacturer that is compatible with the framing, finish, and surrounding materials.
- All sealant bead sizes must conform to the sealant manufacturers' size requirements.
- The Owner / General Contractor is responsible for identifying the need for any additional sealant to be applied by others. Such sealant shall be elastomeric material, with the framing, finish and surrounding materials.

### Load / Anchor Instructions

- Live or Dead Loads can affect product functionality, loads shall be designed to withstand the most critical effects of load factors and load combinations as required by building code.
- Fleetwood requires maximum vertical deflection of the header not to exceed  $\text{Span}/720$  or  $1/8''$
- Structural engineer to determine anchor quantity and spacing for design load requirements.
- Proper material must be used between all dissimilar materials (i.e. block/concrete & aluminum).

## III. Assembly and Installation

**General:** The key to any window or door installation is preparation. This extends from storage of the product to the final installation and to all points in between. Careful planning and attention to detail can help ensure proper installation.

**It is essential that each Fleetwood product be assembled and glazed in accordance with AAMA standards and factory instructions.** It is the installer's responsibility to ensure that each Fleetwood product is assembled, glazed and installed and completely sealed to ensure that the product is leak-free and operates correctly. **Installation of Fleetwood products must be in accordance with the standards set forth in ASTM E 2112.** If there are any questions regarding the installation of a Fleetwood product contact the factory customer service department.

Fleetwood has provided this product with recommended field glazed weather-stripping. If the provided weather-stripping does not ensure an optimum fit of glass to frame the Fleetwood Authorized Dealer should contact Customer Service for an expedited NO CHARGE shipment of replacement weather-stripping.

#### IV. Structure Verification & Sillpan Installation

**Note:** Sillpan Substitution- If the factory provided pan is not desired, the product warranty will remain intact if the substitute panning system emulates the essential design of the factory pan.

##### 1. Opening Verification

- Check the measurements of the opening and verify that the product will fit into the opening. Measure all four sides of the opening to make sure there is a clearance of 1/2" in width and 1/4" in height.
- Remove the product(s) from the packaging and lay it in front of the opening. Check width and height dimensions.
- Verify the opening is plumb and level (Figure 1).

##### 2. Pre-Fit and Leveling

- Place sill-pan into the opening and determine any leveling that must be done prior to installation
- Shim as necessary to stabilize the entire depth and length of the pan. No unsupported width of more than 8" is allowed. Shim to be load bearing, non-porous, non-absorbent and inorganic.
- If more than 1/8" shim height is required, it is recommended that pouring self-leveling "Rock Hard" (or equal) to achieve level and stable surface.

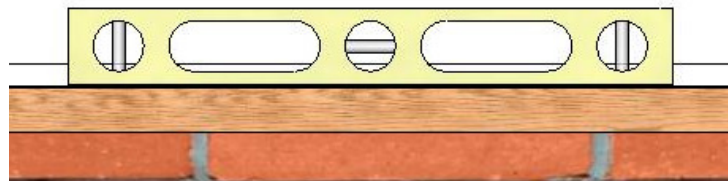
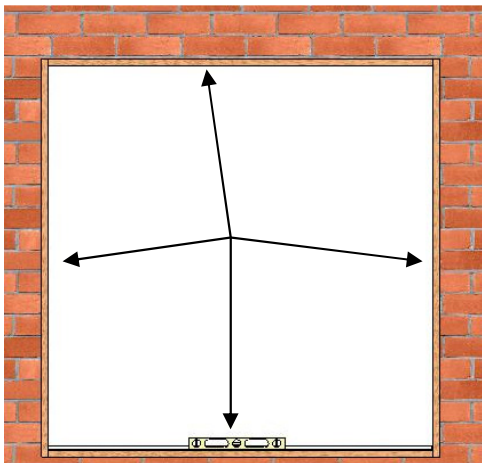
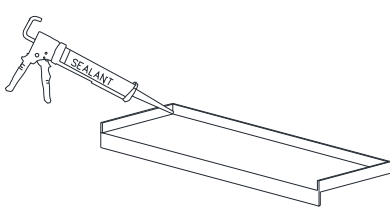

**Figure 1:**  
Use level to determine if the opening is plumb and level

### 3. Sill-pan Installation

**Note:** For splicing and multiple piece Sill-pans – (See Appendix A)

- Apply bituminous paint to raw masonry or concrete at the sill to eliminate electrolytic and chemical reactions. We recommend a PVC liner be placed to ensure separation of the metal frame with the substrate. In balcony situations flash the sill with aluminum or galvanized brake metal (Sill-pan is provided).
- Apply sealant in all corners and seams of the sill-pan (Figure 2).
- With bottom side of sill-pan up, apply a 3/8" bead of compatible sealant 1/2" in from interior leg. Sealant bead to run across the bottom as well as up each vertical leg of the sill pan. Also apply sealant beads near the sides and across the front (Figure 3).
- Secure the sill-pan to the floor with sealant. Position sill pan as necessary to allow for proper installation of frame assembly (Figure 4).



**Figure 2:**  
Seal corners and seams

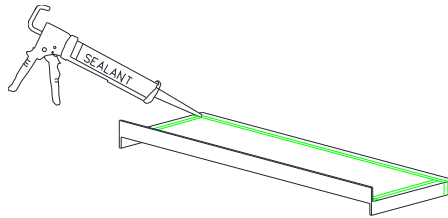

**Figure 3:**  
Seal underside of Sill-pan

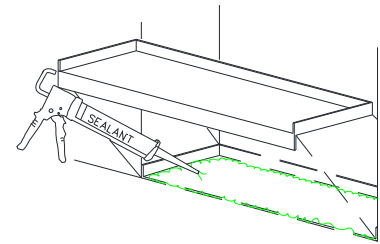

**Figure 4:**  
Set pan in full bed of sealant

### V. Glazing Assembly

1. Start attachment of glazing vinyl at top corner of the glass.
2. Cut glazing vinyl at corners as shown in Figure 5, Detail "A".
3. At start/end point (seam), cut glazing vinyl 1/8" oversize to compensate for stretching.
4. Apply sealant to top portion of this seam.
5. Apply a bead of sealant that is compatible with the insulated glass seal to all four exterior corners as shown in Figure 5, Detail "A".

**Notes:**

- a. The glass thickness, net width and height must be to size within  $\pm 1/32$ ".
- b. Failure to install according to these instructions nullifies all warranties related to this product.

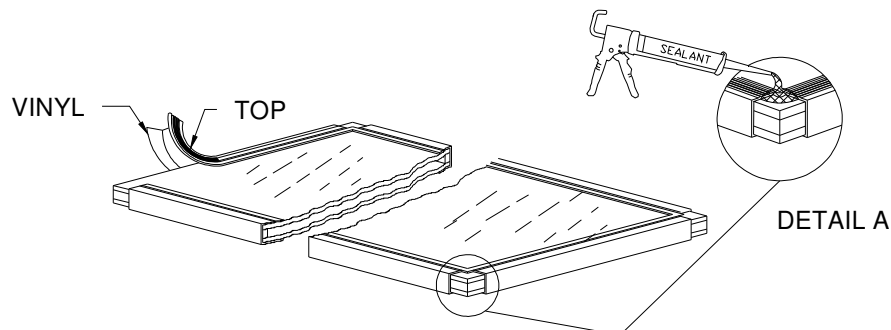

**Figure 5:**  
Glazing Vinyl Application

## VI. Panel Assembly

**Note:** Match door configuration and panel orientation with customer order. Configuration and orientation of panels shown in assembly instructions is for illustration purposes only.

### “X” Panel

1. Adjust the roller assemblies (2 required per “X” panel) to the full up right position using the adjustment screw (Figure 6). Ensure the roller and the roller housing are positioned correctly in the bottom rail.
2. With weather-strip facing down, center the top rail onto the glass. Using a rubber mallet, drive the rail onto the glass until the rail seats against the vinyl lip. Repeat this procedure with the bottom rail.
3. Slide the Vinyl sweep into the top groove of the bottom rail 13/16” on interlocker side and 2 3/4” on lead stile side.

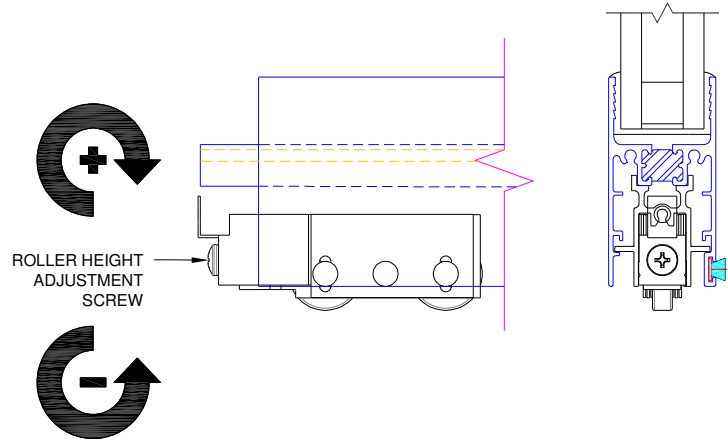
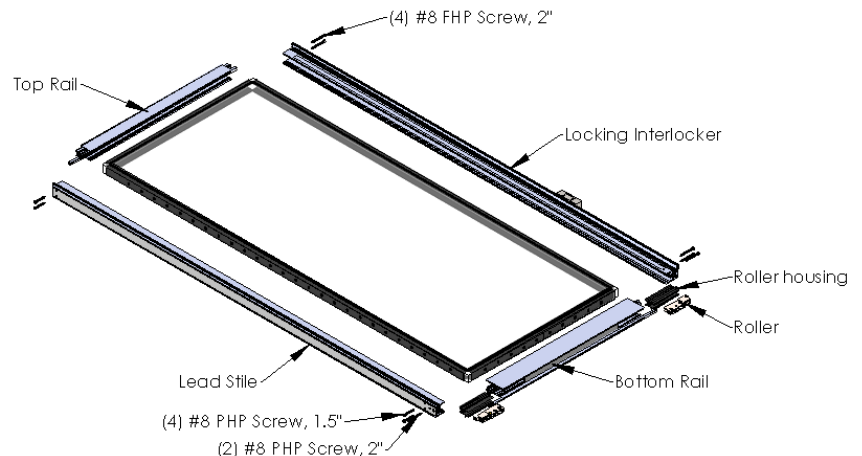

**Figure 6:**  
Roller Adjustment

**Note:** Prior to adjusting the roller on **ANY** door you **MUST** first remove the weight of the panel.

**Note:** Before installing lead and interlocker stiles to panels please check required orientation with customer order

4. Place the interlock stile; hook facing up on the right side for XO, and hook facing up on the left side for OX.
5. Position the interlocker stile on one side as described above and drive it onto the glass.
6. Position the lead stile or interlocker stile on opposite side with weather-strip facing up and drive it onto the glass.
7. Secure the stiles to the top and bottom rail with (4) #8 x 2” flat head screws for the interlocker and (4) #8 x 1-1/2” pan head screws for lead stile (Figures 7).
8. Align the Roller with the Roller housing then fasten into the stile with #8 x 2” pan head screw.



**Figure 7:**  
“X” Panel Assembly (exterior)

**“O” Panel**

1. With the weather-strip facing up, center the top rail onto the glass. Using a rubber mallet, drive the rail onto the glass until the rail seats against the vinyl lip. Repeat this procedure with the bottom rail.

**Note:** Before installing fixed and interlocker stiles to panels please check required orientation with customer order.

2. Place the interlock stile; weather-strip facing down on the right side for OX, and weather-strip facing down on the left side for XO.
3. Position the interlocker stile on one side as described above and drive it onto the glass.
4. Position the fixed stile or interlocker stile on other side and drive it onto the glass.
5. Secure the stiles to the top and bottom rail with (4) #8 x 2” flat head screws for the interlocker and (4) #8 x 1-1/2” pan head screws for lead stile (Figures 8).
6. Insert vinyl plugs at top and bottom of stiles.

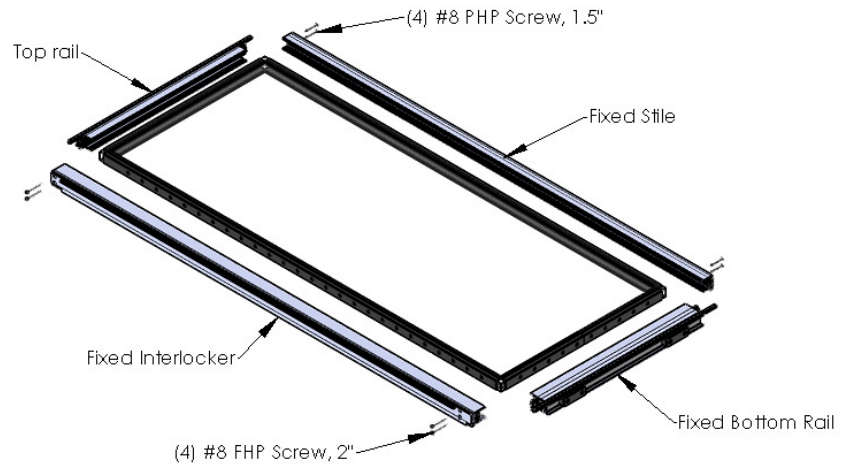

**Figure 8:**  
“O” Panel assembly  
(interior)

**“O” Panel (non-interlocker)**

1. Center the top rail onto the glass. Using a rubber mallet, drive the rail onto the glass until the rail seats against the vinyl lip. Repeat this procedure with the bottom rail.
2. Position the fixed stiles on sides with the mohair up and drive it onto the glass.
3. Finish assembly by inserting (8) #8 x 1.5” pan head screws into the fixed stile screw grooves in the top and bottom rails (Figure 9).

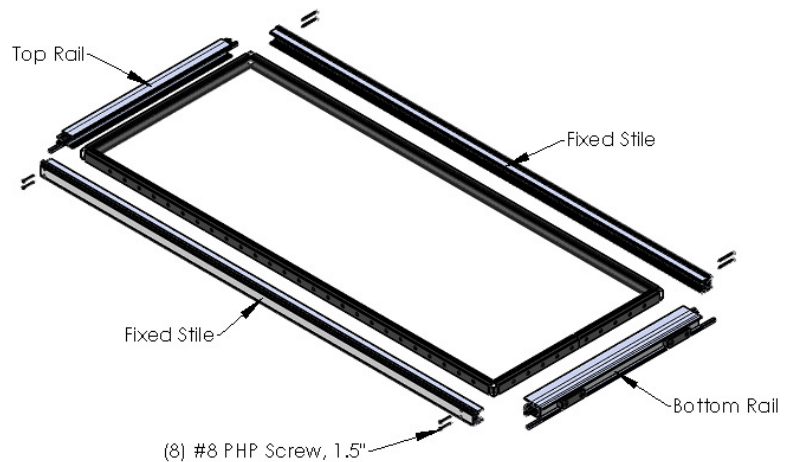
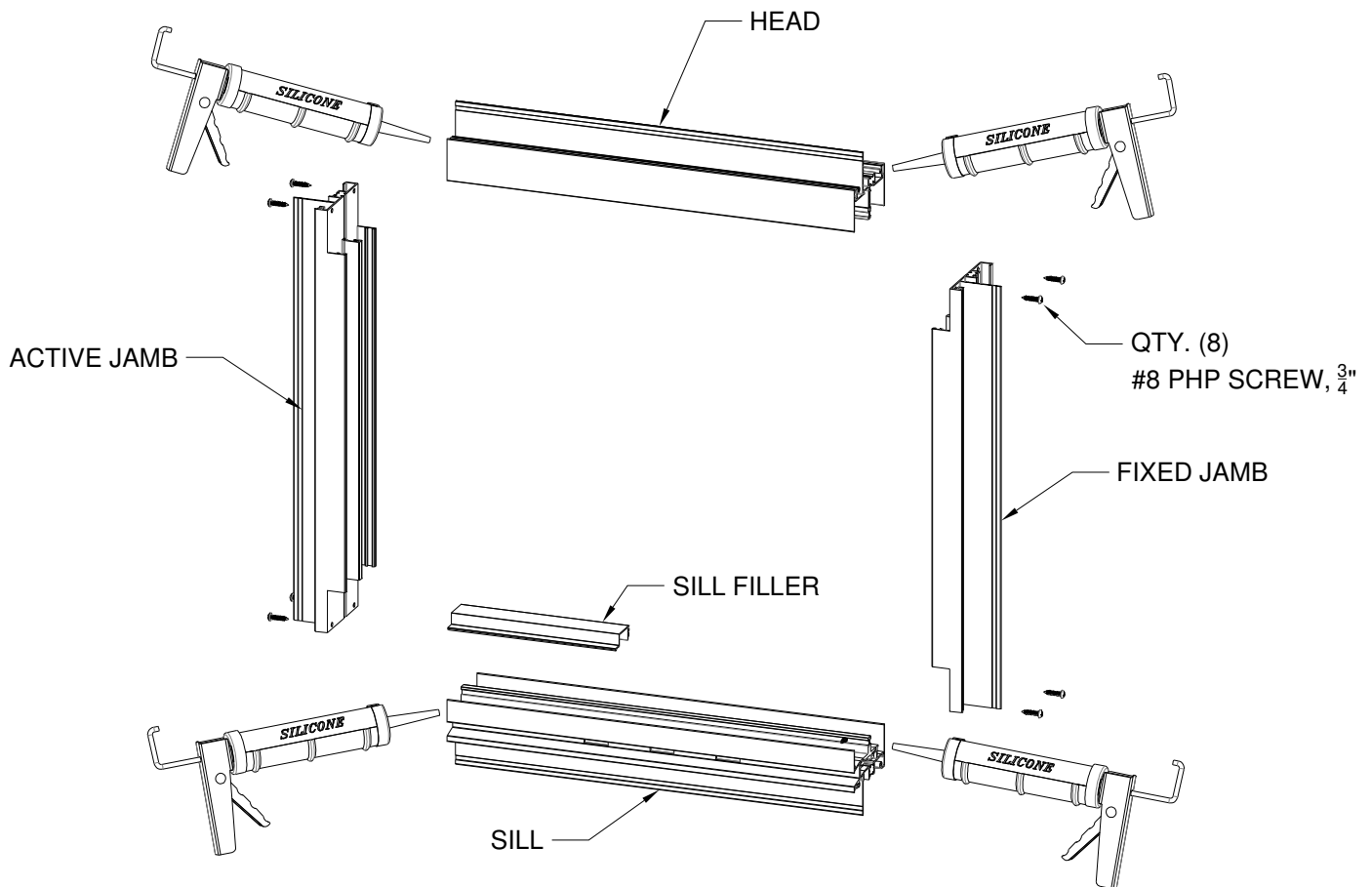

**Figure 9:**  
“O” Panel assembly non-interlocker

**VII. Frame Assembly**

**Note:** Failure to assemble the frame according to the installation instructions, nullifies warranties related to this product.

1. Remove, and set aside the sill filler
2. Apply a compatible sealant to the ends of the head and sill. Assemble the frame with screws provided (Figure 10).



**Figure 10:**  
Frame Assembly



**VIII. Nail-fin Frame Installation**

**Note:** Fleetwood recommends the use of a laser level or 8' level for frame installations. Cross-measure within  $\pm 1/32"$  for interior and exterior.

1. Prepare the opening to accept the frame ensuring that the weep-screed flashing at the sill is adjusted to maintain a weatherboard style flashing.
2. Flashing paper must be applied with galvanized nails or corrosion resistant staples. Flashing paper shall be applied in a weatherboard fashion around the full perimeter of the framed opening.
3. Apply a continuous bead of sealant along the back and side legs between the sill and sill pan (Figure 11,12) and insert the frame into the opening.
4. Cross-measure and adjust using non-porous, non-absorbent, inorganic shims to achieve a plumb square and level condition, as well as an even reveal around the framed opening. Ensure shims are in a location to support any loads that are transferred from the anchor to the frame. Seal all fastener heads with compatible sealant. Only drill holes through Sill as required for design load. In these cases, the installer is responsible to seal these breaches.

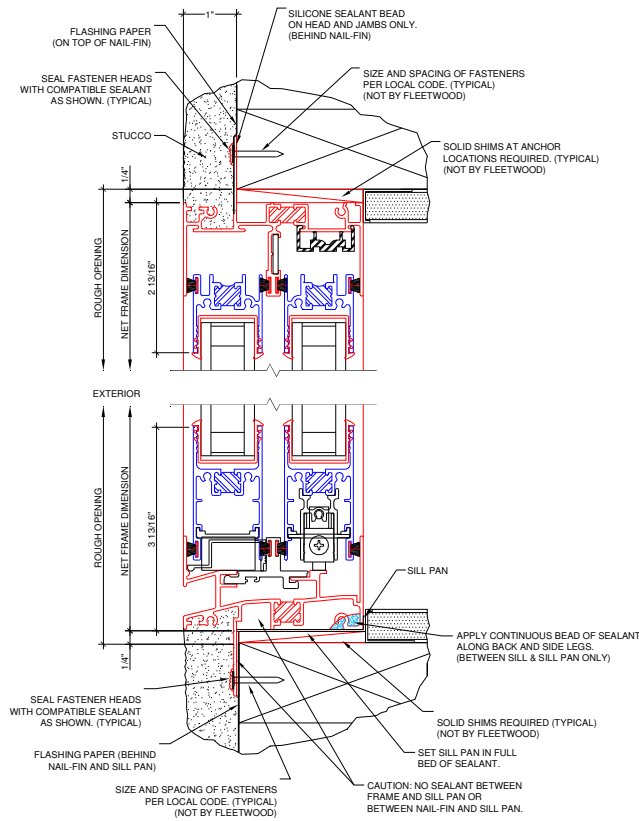

**Figure 11:**  
Nail-fin Horizontal Slider  
Installation

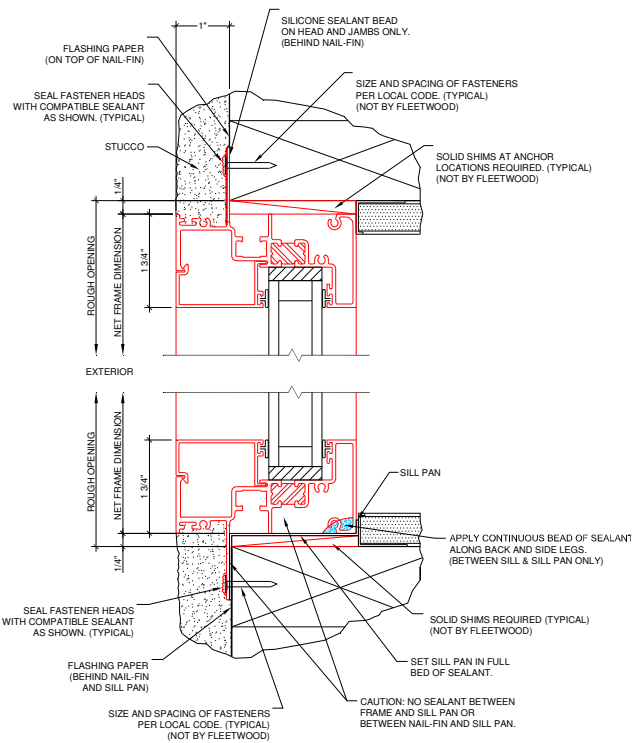
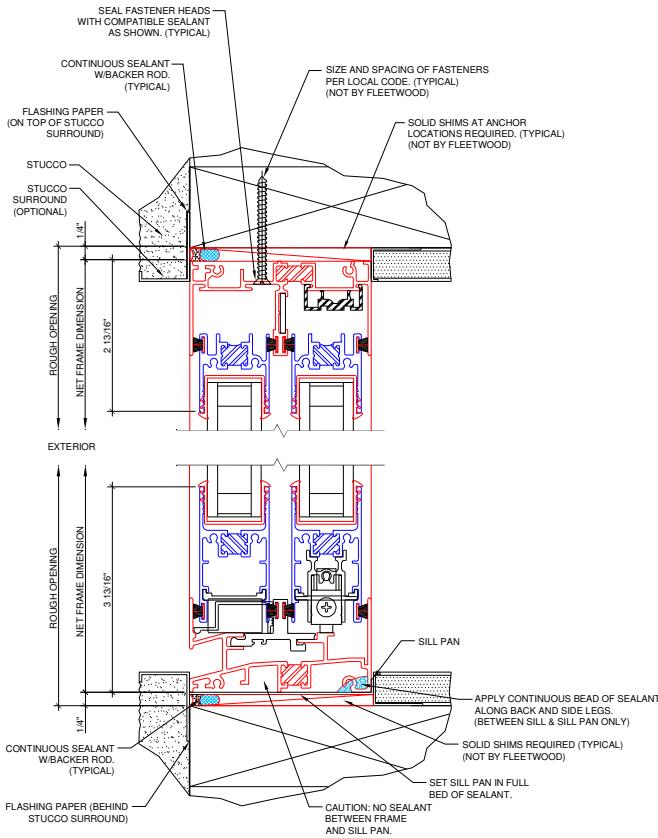

**Figure 12:**  
Nail-fin Glazed to Frame Installation

**IX. Block Frame Installation**

**Note:** Fleetwood recommends the use of a laser level or 8' level for frame installations. Cross-measure, tolerance is within  $\pm 1/32$ " for interior and exterior.

1. Prepare the opening to accept the frame ensuring that the weep-screed flashing at the sill is adjusted to maintain a weatherboard style flashing.
2. Flashing paper must be applied with galvanized nails or corrosion resistant staples. Flashing paper shall be applied in a weatherboard fashion around the full perimeter of the framed opening.
3. Apply a continuous bead of sealant along the back and side legs between the sill and sill pan (Figure 13,14) and insert the frame into the opening.
4. Cross-measure and adjust as necessary to achieve a plumb square and level condition, as well as an even reveal around the framed opening. Shim with non-porous, non-absorbent, inorganic shims where needed. Seal all fastener heads with compatible sealant. (Only drill holes through Sill as required for design load)



**Figure 13:**  
Block Frame Horizontal Slider  
Installation

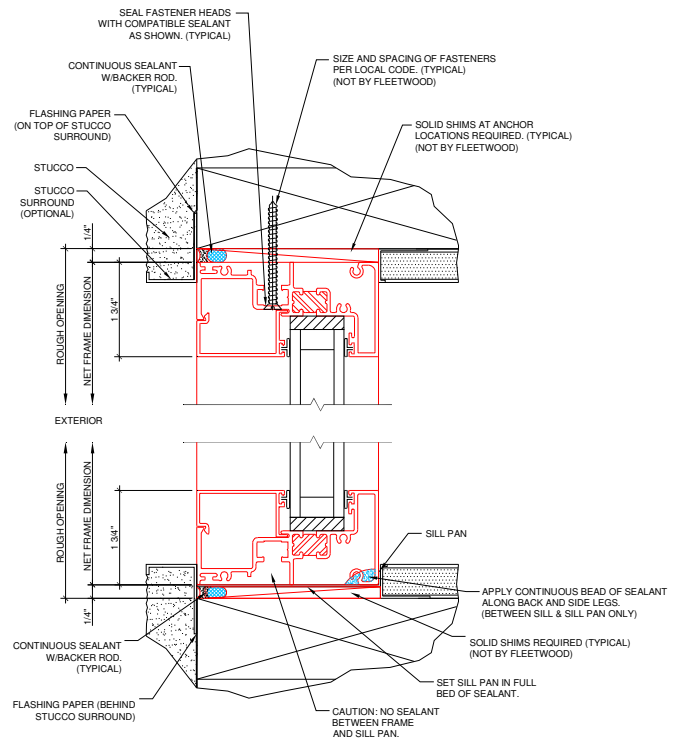

**Figure 14:**  
Block Glazed to  
Frame Installation

## X. Panel Installation

**Note:** Check customer order for proper panel configuration and orientation.

### “X” Panel

1. Sequence of panel installation is from interior to exterior.
2. Insert panel (panel located on the track closest to the interior) into the upper head channel. Push up and swing the bottom inward until panel is vertical, then lower panel down onto the track (Figure 15).

**Note:** “X” Panel - Do not attempt to slide the panel unless the rollers have been adjusted. Adjust the rollers as needed to make the panel plum and level.

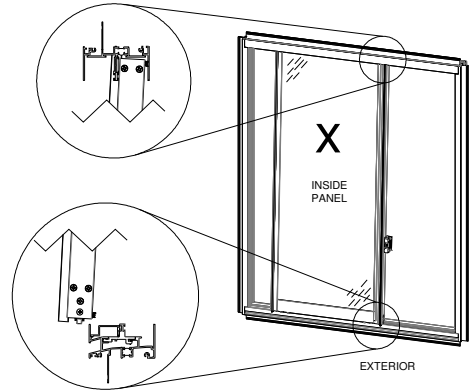

**Figure 15:**  
“X” Panel Installation

### “O” Panel Installation

1. Remove the sill filler from the frame assembly (Figure 6).
2. Unscrew the T-Clip in the head (Figure 17).
3. Insert the panel into the upper head channel. Push up and swing the bottom inward until panel is vertical, then lower panel down onto the sill (Figure 17).
4. Lift and move the panel into the fixed jamb until the fixed stile is 3/4” exposed (Figure 18).
5. For “XOX” configurations, center “O” panel accordingly in frame before securing.

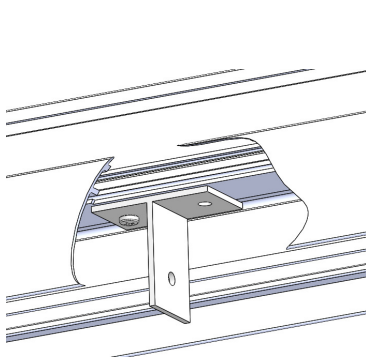

**Figure 16:**  
T-Clip Installation / Removal

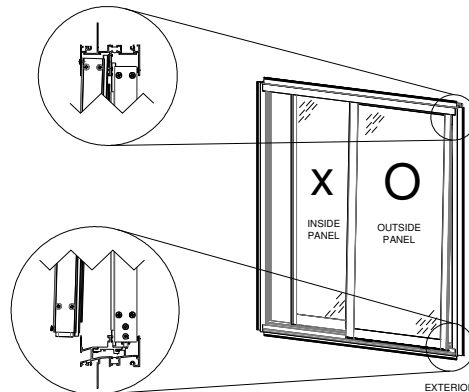

**Figure 17:**  
“O” Panel Installation

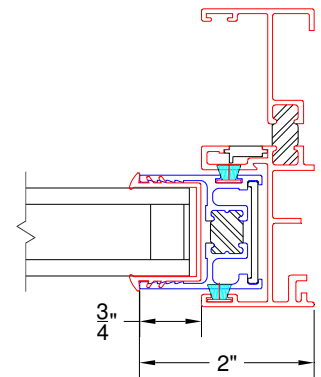

**Figure 18:**  
Panel Reveal

### Securing the “O” Panel

1. Reinstall the sill filler and the T-Clip.
2. Secure the T-Clip into the head and then fasten to the fixed interlocker with a #6 x 1/2” Pan Head TEK Screw.
3. From the interior, using a 1/8” drill bit, drill a hole into the fixed stile through the mohair channel (Figure 19). Then insert a black #8 x 3/4” FHP TEK security screw.

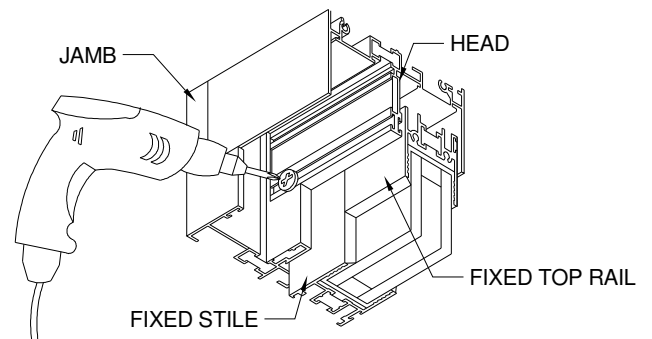

**Figure 19:**  
Security Screw Installation

**XI. Anti-lift**

Install the anti-lift block at the middle of the opening for the active panel track. The use of a hammer and block wedge may be required to fully insert anti-lift(s) (Figure 20).

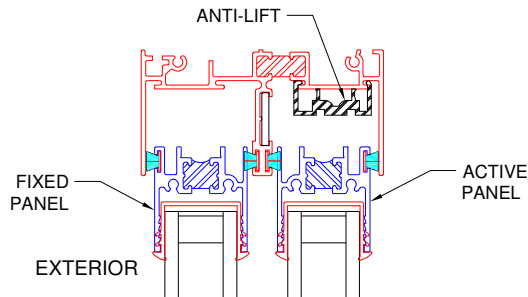

**Figure 20:**  
Anti-lift location

**XII. "O" Panelized Installation**

1. Assemble the panel according to the "O" panel non-interlocker instructions in section VI.
2. The frame should have panel stops and wedge stops pre-fastened to receive the panelized lite (Figure 21).
3. Installation of the panel is from the interior.
4. Insert the panel into the upper head channel. Push up and swing the bottom inward until panel is vertical, then lower panel down onto the sill.
5. Cut to size the "O" panel wedges. Start with the head and sill, Insert the "O" panel wedges to secure the panel. Once the head and sill are secured insert the vertical "O" panel wedges.

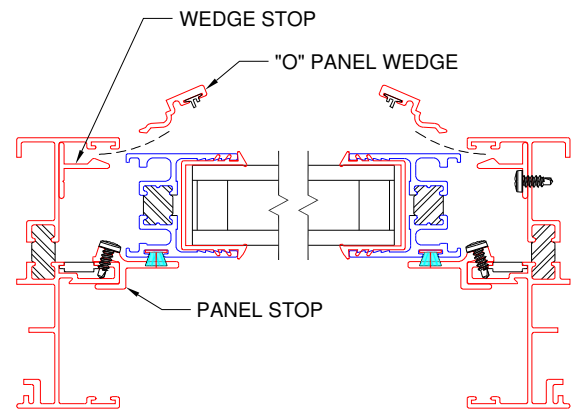

**Figure 21:**  
"O" Panelized Installation

**XIII. Screen Installation**

1. Insert the screen adapter into the outer jamb (Figure 22).
2. Fasten the screen adapter using a #6 x 3/8" Philips screw spaced out evenly along the
3. Insert the screen into the upper head. Push up and swing the bottom inward until lower down onto the sill.

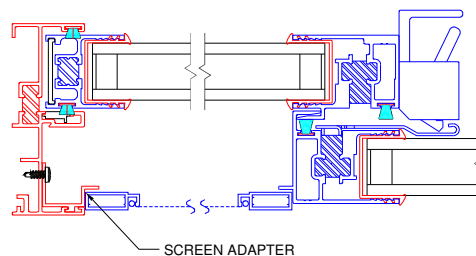

channel of the  
Pan Head  
jamb.  
channel.  
vertical, then

**Figure 22:**  
Security Screw Installation