

Table of Contents

I.	Care and Maintenance	2
II.	Tools / Materials, Sealant Requirements, & Anchor Instructions	2
III.	Assembly and Installation	2
IV.	Frame Opening Verification & Sillpan Installation	3
	1. Opening Verification	3
	2. Flash the Opening	3
	3. Pre-Fit and Leveling.....	3
	4. Sealant Application.....	4
V.	Glazing Assembly.....	5
VI.	Panel Assembly (If panels were ordered glazed, skip to section IV).....	5
	“X” Panel	5
	“O” Panel.....	7
VII.	Frame Assembly.....	8
VIII.	Sill Assembly for 90° Corner Doors.....	9
IX.	Frame Installation.....	9
X.	Sill Track Installation.....	11
XI.	Sill Track Removal	11
XII.	Aluminum Sill Pan Hem Cover Installation	11
XIII.	Pocket Closer and Head Bumper Installation.....	12
XIV.	Pocket Interlocker Installation	13
XV.	2 Piece Pocket Interlocker Clip Installation and Removal.....	13
XVI.	Panel Installation	14
XVII.	Air Barrier Installation (Optional).....	15
	Appendix A: 90° Lead Stile Roller Attachment (When panels are KD).....	16
	Appendix B: Reverse HP Pocket Interlocker Installation	17

I. Care and Maintenance

This product is factory finished. Please handle with extreme care. Protect all exposed surfaces from contact with caustics, corrosives, solvents, abrasions, impacts, wet packing material etc. **FAILURE TO DO SO WILL NULLIFY THE WARRANTY.** Before ANY CLEANING, review the Care & Maintenance Instructions (go to www.fleetwoodusa.com for more information).

Contact the local dealer with any questions or concerns. Fleetwood strongly recommends that all products be cleaned after installation and totally protected from construction debris and equipment.

II. Tools / Materials, Sealant Requirements, & Anchor Instructions

Tools Required: Tape measure, level, shims, nails, rubber mallet, putty knife, screws, sealant, caulk gun, backer rod, 6mm hex wrench, scissors or utility knife, drill bit, drive bit and powered drill.

Sealant Requirements

- The sealant referred to within this document is associated with the assembly of the product shall conform to **AAMA 800-16**. It is recommended that all other sealants should also conform to **AAMA 800-16** but may be a sealant recommended and approved by the sealant manufacturer that is compatible with the door framing, finish and surrounding materials.
- The size of all sealant beads must meet or exceed the sealant manufacturers' minimum size requirements.
- Some exterior wall finishes require additional sealing between the perimeter of the door frame and adjacent finish wall material. The Owner / General Contractor is responsible for identifying the need for any additional sealant which will be applied by others. Such sealant shall be elastomeric material, and compatible with the door framing, finish and surrounding materials.

Anchor Instructions

Frame may be either direct mounted to the opening, mounted onto a continuous wood spacer, anchored to a min. 18 ga. 33 ksi metal stud or anchored to a min. 2x4 no. 3 southern pine wood buck. When anchored to a 2x_ buck or metal stud, no. 12 screws shall be used. When direct mounted or mounted with spacer to block/concrete, 1/4" concrete screws shall be used. Proper material shall be used between all dissimilar materials (block/concrete & aluminum).

III. Assembly and Installation

It is essential that each Fleetwood product be assembled and glazed in accordance with AAMA standards and factory instructions. Refer to the specific product assembly and glazing instructions on separate sheets. If necessary, contact the factory to obtain a copy of these instructions. It is the installer's responsibility to ensure that each Fleetwood product is assembled, glazed and installed and completely sealed to ensure that the product is leak-free and operates correctly. **Installation of Fleetwood products must be in accordance with the standards set forth in ASTM E 2112.** If there are any questions regarding the installation of a Fleetwood product contact the factory customer service department.

IV. Frame Opening Verification & Sillpan¹ Installation

Note: Sillpan Substitution- If the factory provided sillpan is not desired, the product warranty will remain intact if the substitute panning system emulates the essential design of the factory pan. This sliding door system has passed specific air, water, energy and structural testing with the factory provided sillpan.

1. Opening Verification

- Check the measurements of the opening and verify that the door will fit into the opening

2. Flash the Opening

- Once the opening has been confirmed, the opening should be flashed prior to Frame installation. Check local Building codes for any flashing requirements.
- At each Jamb the flashing paper should be cut at least 3" past the weep-screed or diado flashing and at least 6" above the head of the door. The flashing must wrap around the jamb and at least 3" back into the opening (Figure 1).
- At the Head run the flashing paper long enough to extend at least 3" past the jamb flashing and wrap around the Header at least 3" into the opening (Figure 2).

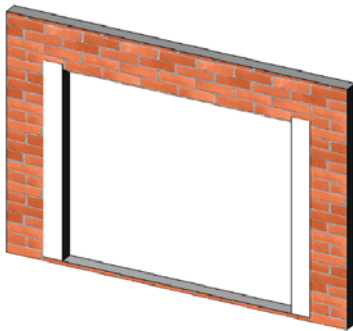

Figure 1:
Jamb Flashing

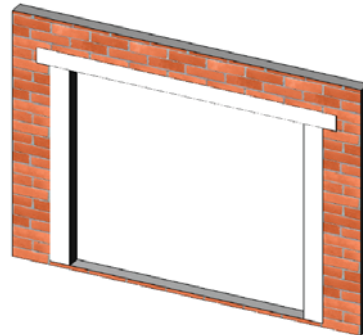

Figure 2:
Head Flashing

3. Pre-Fit and Leveling

- Place sillpan into the opening and determine leveling (Figure 3) that must be done prior to installation.
- Shim as necessary to stabilize the entire depth and length of the sillpan. No unsupported width of more than 8" is allowed.
- If more than 1/8" shim height is required, it is recommended that pouring self-leveling "Rock Hard" (or equal) to achieve level and stable surface.

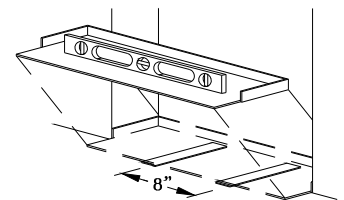

Figure 3:
Sillpan leveling

¹ Sillpan refers to a factory provided aluminum pan (or equivalent).
DOC: Series 3070-1070 Installation Instructions

4. Sealant Application

- Apply bituminous paint to raw masonry or concrete at the sill to eliminate electrolytic and chemical reactions. It is recommended a PVC liner be placed to ensure separation of the metal frame with the substrate. In balcony situations flash the sill with aluminum or galvanized brake metal (Sillpan is provided).
- Apply sealant in all corners and seams of the sillpan (Figure 4).
- With bottom side of sillpan up, apply a 3/8" bead of compatible sealant 1/2" in from interior leg. Sealant bead to run across the bottom as well as up each vertical leg of the sillpan. Also apply sealant beads near the sides and across the front (Figure 5).
- Secure the sillpan to the floor with glue. Position sillpan as necessary to allow for proper installation of frame assembly (Figure 6).

Note: For pocket doors do not forget required space for post interlocker. Sill track is located 3/8" from pocket wall on side with post interlocker.

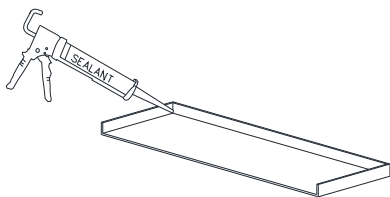

Figure 4:
Seal corners and seams

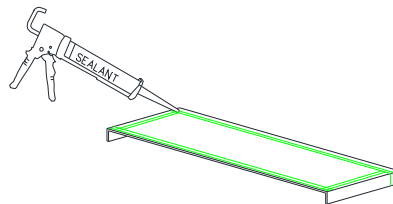

Figure 5:
Seal underside of Sillpan

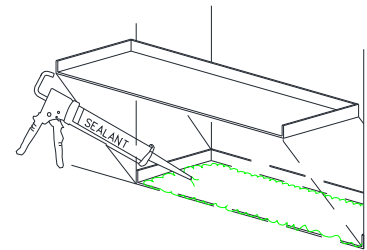

Figure 6:
Set pan in full bed of sealant

- If sillpan is more than one piece, butt the pieces and glue them to the floor together.
- Cut a piece of adhesive backed waterproof material to fit the joint as specified in Figure 7, $A=1/4"$. Select waterproofing material that is compatible for your application. Waterproofing material must have an adhesive backing and be capable of withstanding the temperature ranges for your region (Figure 8).
- Apply sealant to all interior and exterior seams.

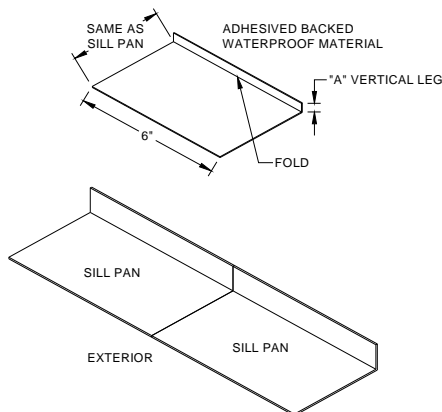

Figure 7:
Joining Sillpans with adhesive backed material

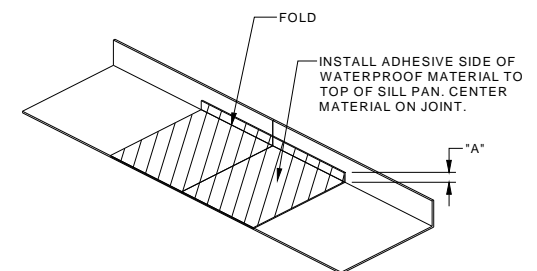
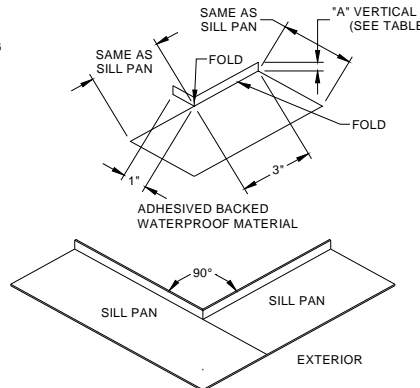

Figure 8:
Adhesive backed material centered on seam

V. Glazing Assembly

1. Start attachment of glazing vinyl at the top corner of the glass.
2. Cut glazing vinyl at corners as shown in 9, Detail "A".
3. At start/end point (seam), cut glazing vinyl 1/8" oversize to compensate for stretching.
4. Apply sealant to top portion of this seam.
5. Apply a bead of sealant that is compatible with the insulated glass seal to all four exterior corners as shown in Figure 6, Detail "A".

Notes:

- a. The glass thickness, net width and height must be to size within $\pm 1/32"$.
- b. Failure to install according to these instructions nullifies all warranties related to this product.

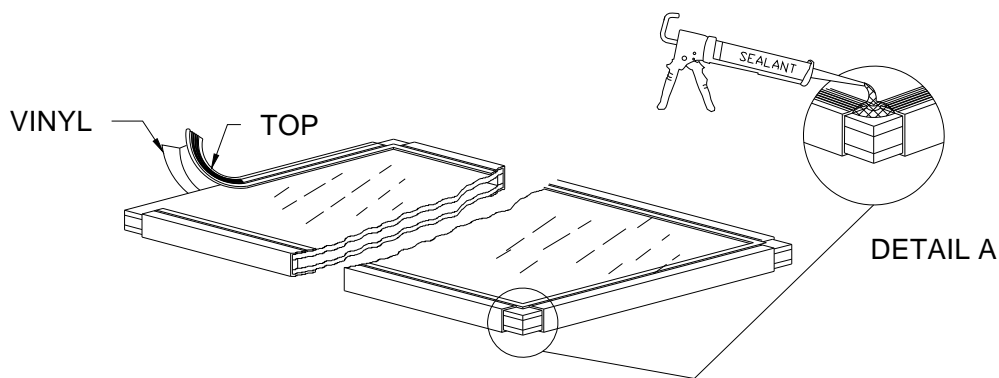

Figure 9:
Glazing Vinyl Application

VI. Panel Assembly (If panels were ordered glazed, skip to section IV)

Note: Match door configuration and panel orientation with customer order. Configuration and orientation of panels shown in assembly instructions is for illustration purposes only. Operating hardware or thumb turns are always to the interior.

"X" Panel

1. Adjust the roller assemblies (2 required per "X" panel) to the full up right position using the adjustment screw (Figure 10).
2. Center the top rail onto the glass. Using a rubber mallet, drive the rail onto the glass until the rail seats against the vinyl lip.
3. Repeat this procedure with the bottom rail.
4. Position the interlocker stile, weather-strip facing up (on the right for OX, left for XO) and drive it onto the glass.

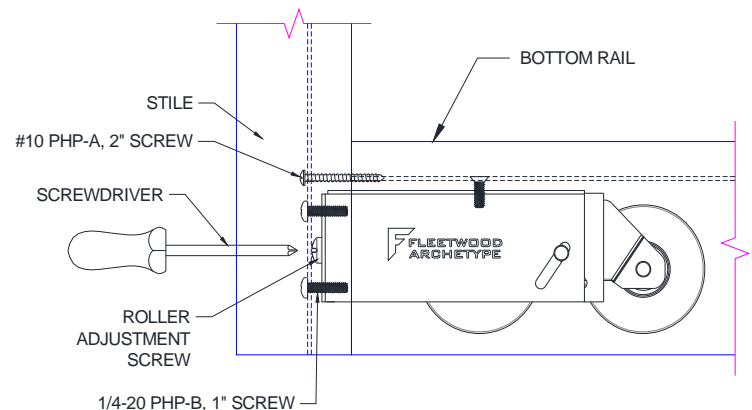

Figure 10:
Roller Adjustment

5. Position the lead stile or interlocker stile on the left side and drive it onto the glass.
6. Secure the stiles to the rails with (4) #10 x 2" pan head screws (Figure 11). Add wax to the ends of all fasteners to reduce the drive torque required for installation.
7. Install (2) ¼-20 UNC x 1" long pan head screws to bottom of interlocker stile or lead stile. Screws attached vertical rails to Roller Housing (Figure 10).
8. On doors with meeting stiles, a stainless steel cover is provided to cover the oblong holes at the bottom of the male meeting stile (Figure 12).

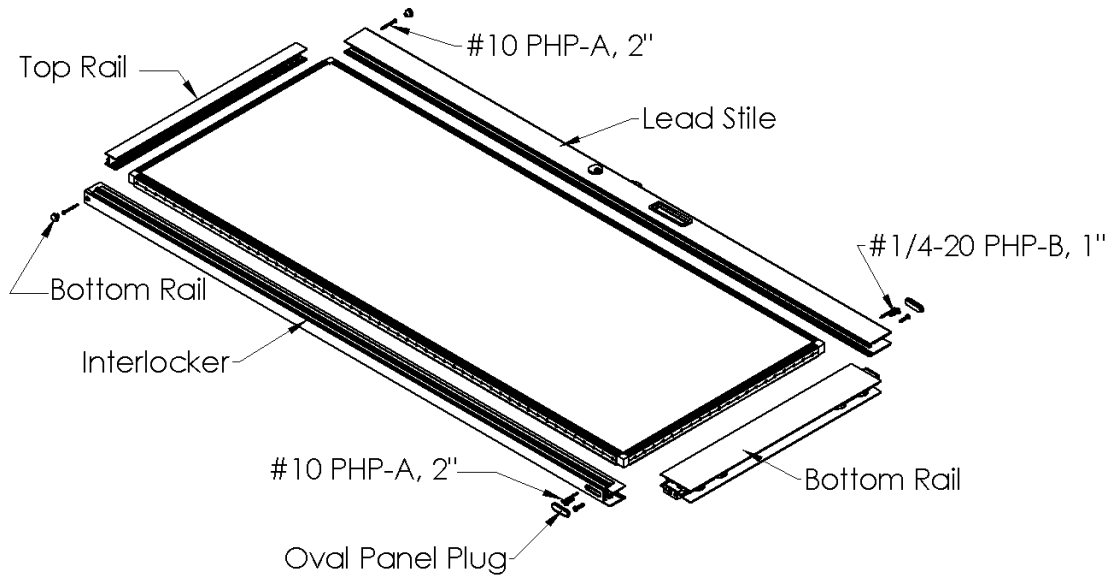

Figure 11:
 X Panel Assembly

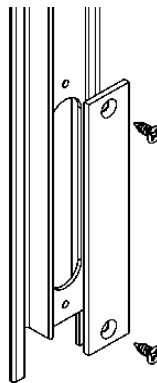

Figure 12:
 Stainless Steel Cover

“O” Panel

1. Center the top rail onto the glass. Using a rubber mallet, drive the rail onto the glass until the rail seats against the vinyl lip. Repeat this procedure with the bottom rail.
2. Position the fixed stile on the right side and drive it onto the glass.
3. Position the interlocker stile on the left side and drive it onto the glass.
4. Secure the stiles to the rails with (4) #10 x 2" pan head screws. Add wax to the ends of all fasteners to reduce the drive torque required for installation.
5. Insert vinyl plugs at top and bottom of stiles (Figure 13).

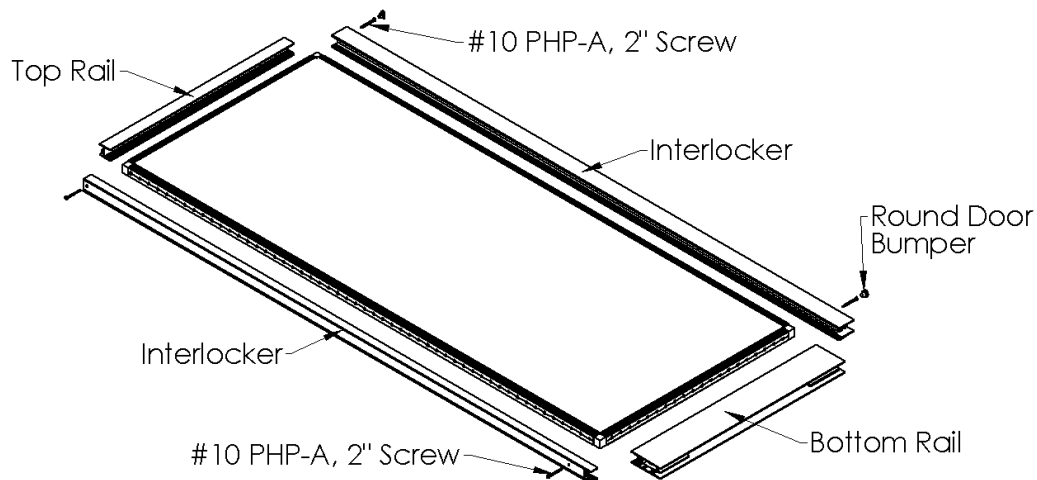

Figure 13:
O Panel Assembly

VII. Frame Assembly

Note: Due to the potential disruption during handling and installation, the installer is responsible for the integrity of all areas requiring sealant whether or not these frames were factory assembled.

1. Remove Jamb Fillers from jambs, these will be installed after frame installation.
2. Add sealant to the upper corners of the jamb(s) and to the end of the head that is compatible to the entire assembly (Figure 14).
3. Attach the jamb(s) to the head using #10 x 3/4" long pan head screws, check that the screws past through jamb(s) and into the screw raceways in the head. Add wax to the ends of all fasteners to reduce the drive torque required for installation.
4. Do not add sealant to the lower corners of the jamb(s) or ends of sill track(s).
5. On pocket installations orient sill track so that no weeps holes are located in pocket.
6. Attach the jamb(s) to the sill using #10 x 3/4" long pan head.
7. If sill riser (optional) is included, insert riser tab into sill pocket and slide together (Figure 15).
8. After frame has been assembled make sure ample sealant is forced in and around each contour at all head joints.

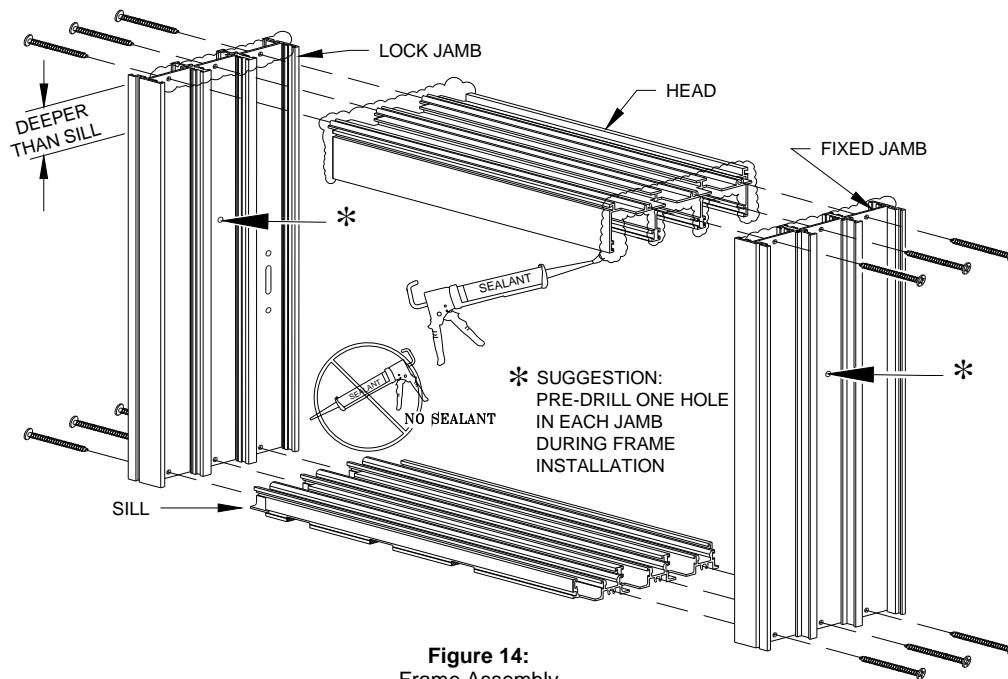

Figure 14:
Frame Assembly

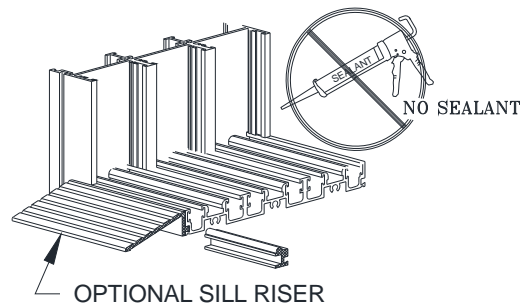

Figure 15:
Optional Sill Riser

VIII. Sill Assembly for 90° Corner Doors

1. Remove the “L-Shaped” braces and Screw #8 FHP - A - UC, 1/2”, SS, Clear from the frame pack. There should be (4) screws per brace (Figure 16).
2. Orient the sill with the bottom side up and install the “L-Shaped” braces as shown in the figure below. Make sure to protect the top side of the sill with cardboard or other materials to prevent damage to the finish while installing braces. Keep corner tight while installing braces to prevent a gap at the mitered corner.

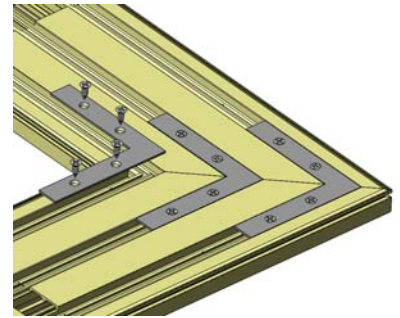
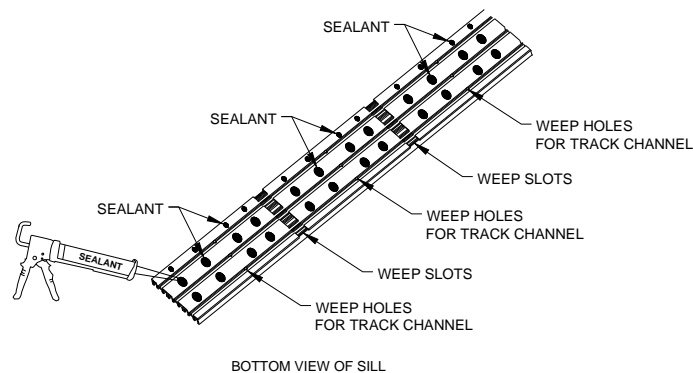

Figure 16:
90° Corner Braces

IX. Frame Installation

1. Attach sill to the sillpan with a compatible sealant (Figure 17). Do not place sealant in or next to weep slots or weep holes cut or drilled in bottom of sill (Figure 18). Sealant that blocks weep slots will prevent sill from weeping.



BOTTOM VIEW OF SILL
Figure 17:
Sill Sealant Locations

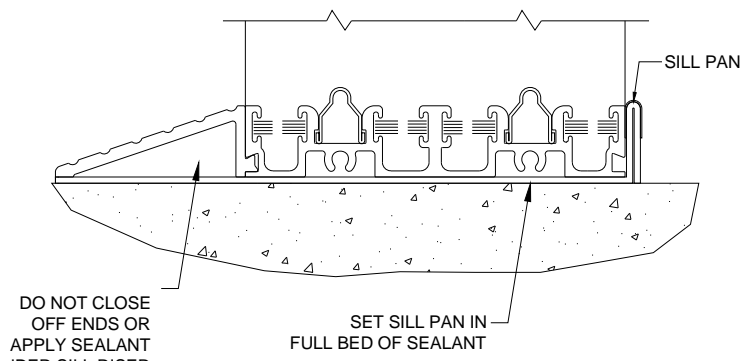

Figure 18:
Sill Sealant Locations

- Attach frame to structure as shown below (Figure 19). On pocket doors using the 2 Piece Pocket Interlocker and L-type Pocket Interlocker it is important to locate the frame 3/8" from the inside pocket wall to allow for proper interlocking of panel with post interlocker. On installations where the J-Post Pocket interlocker clip is used, a 5/16" distance is required.
- Once the frame has been secured to the structure insert the jamb fillers. Using a rubber mallet start at the bottom and gently hammer in place. If the configuration has a fixed panel secure that to the frame first

Note: Size and location of fasteners to be per local code. Frame installation anchors furnished by installer, not by Fleetwood. Stainless steel screws are recommended.

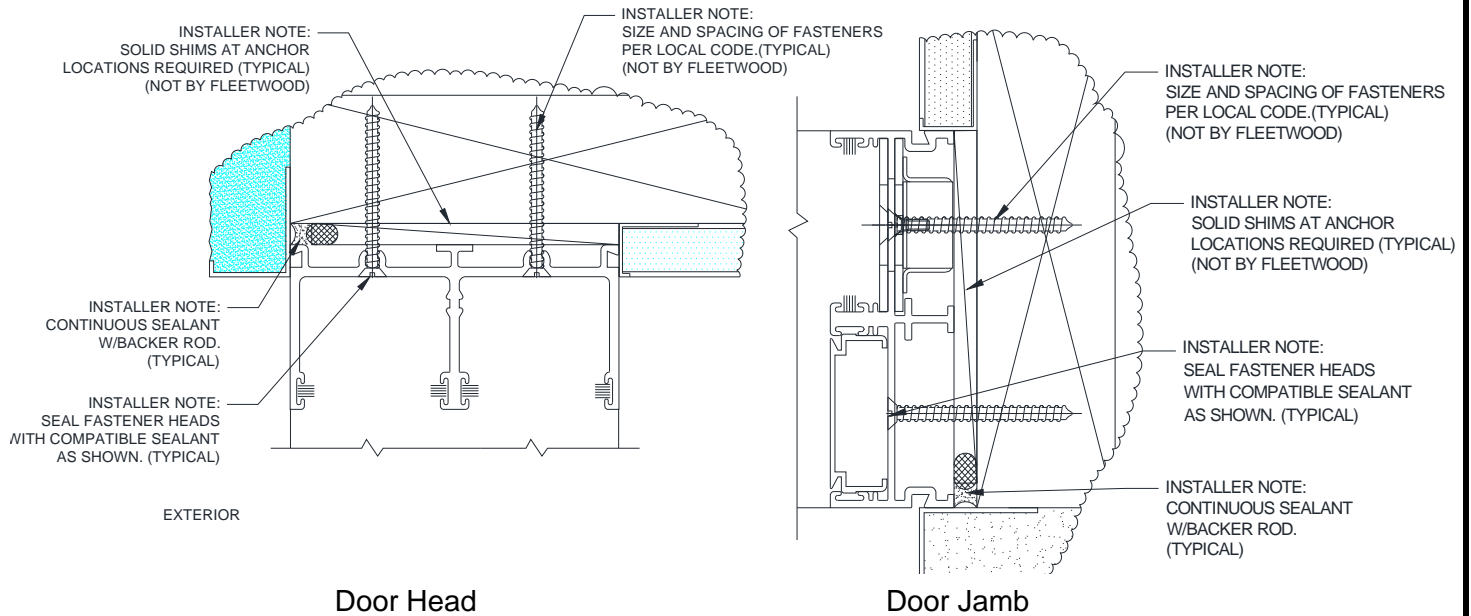

Figure 19:
Door Head and Jamb Anchor Locations

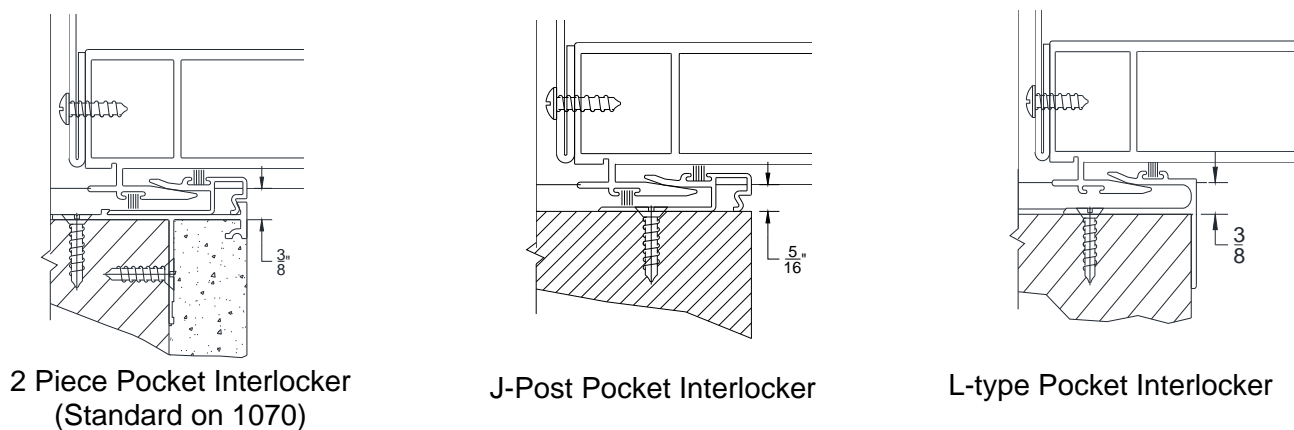

Figure 20:
Pocket Interlocker Options

X. Sill Track Installation

1. Using a pair of pliers, slightly squeeze one end of the track to create a tapered edge.
2. Push tapered edge of track into the sill (Figure 21).
3. Using a rubber mallet, tap the track into the sill.

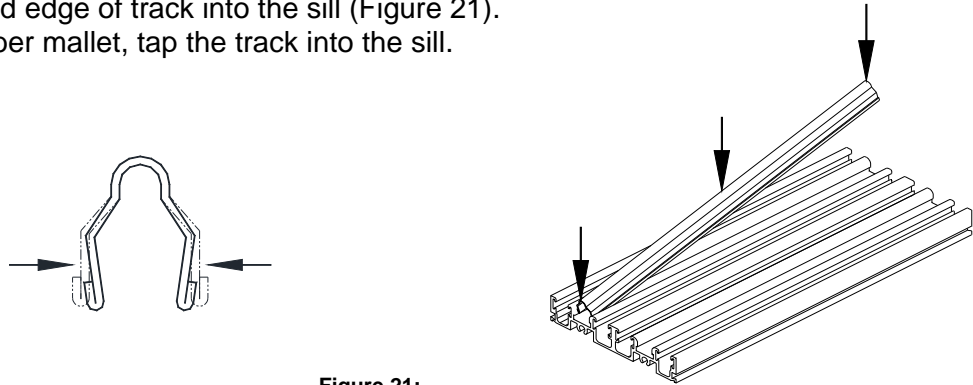

Figure 21:
 Sill Track Installation

XI. Sill Track Removal

1. Using a pair of pliers, slightly squeeze the track together at one end and pull up (Figure 22).
2. Using a screwdriver, slowly pry the track out of the sill. Although you can reinsert the track, we recommend a new track be installed for optimal performance of sliding door.

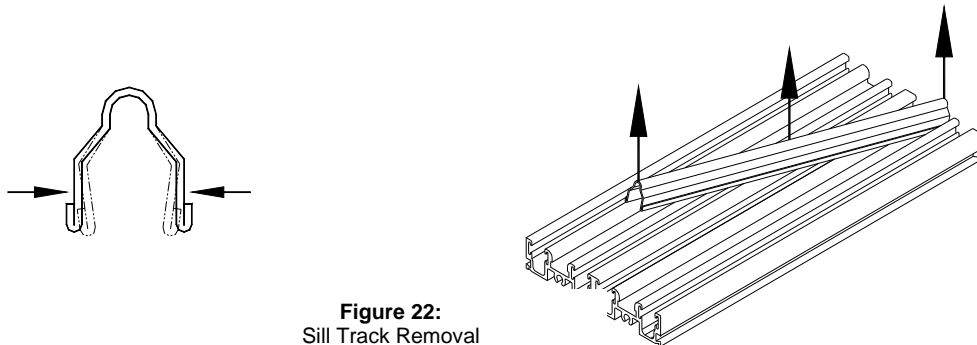

Figure 22:
 Sill Track Removal

XII. Aluminum Sill Pan Hem Cover Installation

1. Push the stainless steel hem cover over the inside water leg of the aluminum sillpan (Figure 23). The hem cover is used to improve the esthetics of the aluminum sillpan.

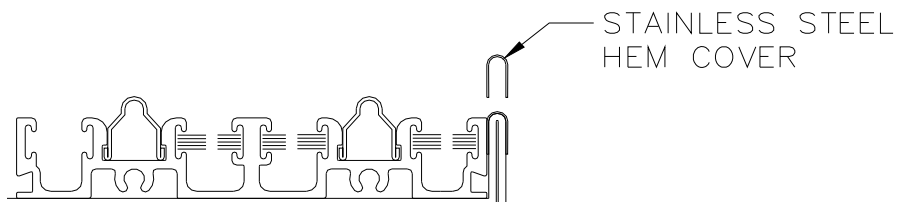

Figure 23:
 Sill Pan Hem Cover

XIII. Pocket Closer and Head Bumper Installation

1. A head bumper (Figure 24) is required in the head of each sliding panel track unless the panels contain door collectors, wind load adapters or high-performance extrusions. See the Multi-slide drawing provided at the time of the order for exact length and number of door bumpers required.
2. If no drawing is available, use a 2-5/8" long head bumper for PX and XP configurations. For configurations with two or more glass panels (PXX, PXXX, etc.) use a 2" head bumper in the track of the longest panel. To determine the length of the head bumpers for the remaining tracks measure the width of each panel. Subtract the measured panel width from the longest panel width plus the head bumper length for that panel (either 2" or 2-5/8").



Figure 24:
Head Bumper

Example:

- Longest panel width is 47" plus the head bumper for that panel is 2", total equals 49".
- Subtract the measured panel width of other panels from the 49". (49" subtract 45-5/8" = 3-3/8")
- The 3-3/8" dimension is the required bumper length for that panel.

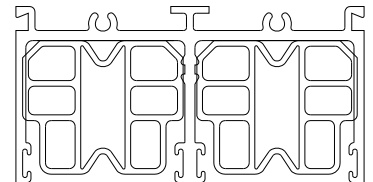

Figure 25:
Head Bumper Installation

3. Install head bumpers into head (Figure 25).
4. Drill .136 diameter holes (#29 drill) thru pocket closer and one wall of interlocker. Holes to be located 6" from top and bottom of pocket closer, then evenly spaced on 12" centers. Assemble pocket closer to back side of interlocker with #10 x 3/4" long pan head screws (Figure 26).

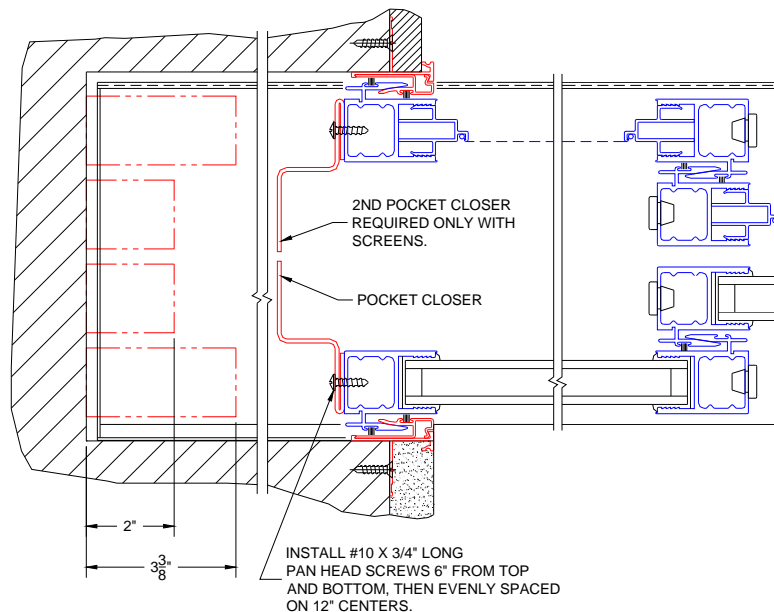

Figure 26:
Pocket Closer

XIV. Pocket Interlocker Installation

1. Assuming that all door and screen panels will be installed from the exterior, the interior pocket interlocker is installed before any screen or door panels.
2. Pocket and Reverse HP L-type Pocket interlockers are furnished net frame height and must be field cut.
3. Attach pocket interlocker(s) with #8 flat head screws, not by Fleetwood. Install screws 6" from top and bottom with additional screws on 18" centers (Figure 27).

Note: PX and XP door panels can be taken out by removing the lock stile and the Pocket Interlocker clip attached to the frame. Dependent on the pocket interlocker type, removal of the wall may be necessary (Figure 20, Figure 27-29).

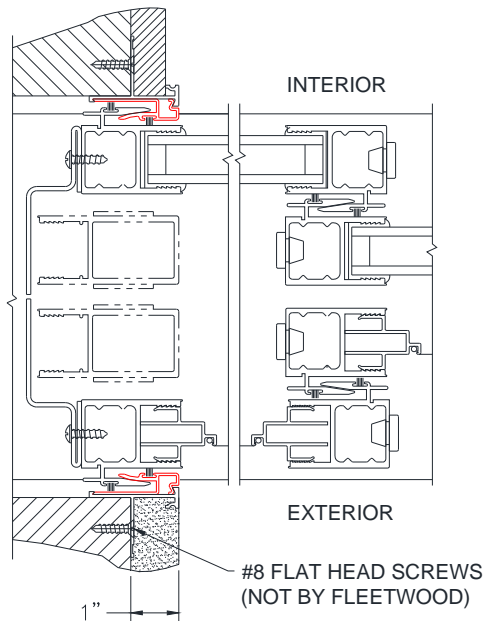

Figure 27:
Pocket Interlocker Installation

XV. 2 Piece Pocket Interlocker Clip Installation and Removal

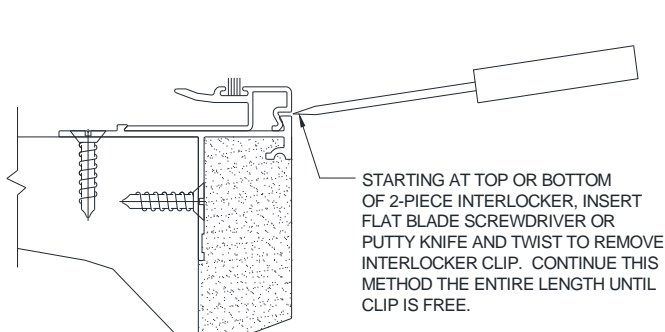

Figure 28:
Pocket Interlocker Clip Removal

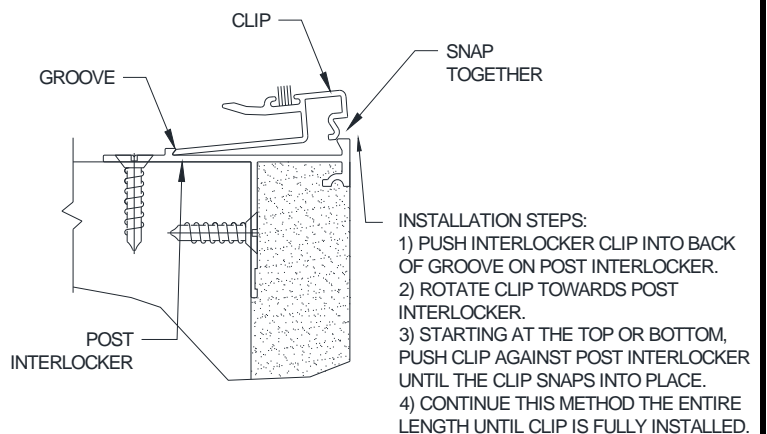

Figure 29:
Pocket Interlocker Clip Installation

XVI. Panel Installation

Note:

- a) Check customer order for proper panel configuration and orientation.
 - b) Pocket walls: Installer to flash inside pocket walls to adequately protect from moisture.
 - c) On pocket doors, installation of panels should be completed before construction of pocket is complete.
1. Sequence of panel installation is from interior to exterior.
 2. Insert panel into the upper head channel (Figure 30). Push up and swing the bottom inward until panel is vertical, then lower panel down onto the track. On PX or XP configurations, if the pocket construction has been completed, it may be necessary to remove the lead stile from the panel before installation into the frame can be accomplished.

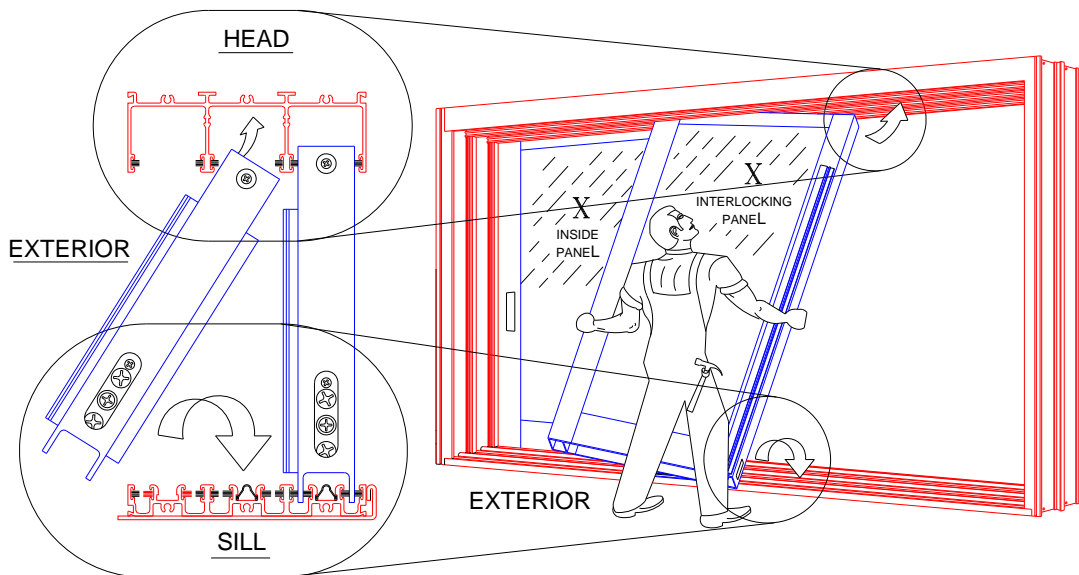

Figure 30:
Panel Installation

- **“X” Panel-** Do not attempt to slide the panel unless the rollers have been adjusted. Adjust the rollers as needed to make the panel plumb and level. Before adjusting rollers, lift panels to relieve weight. If the panel contains a lock stile, verify that the latch height is correct for proper operation with the frame. Insert vinyl plugs into the holes at top and bottom of the panel.
- **“O” Panel-** Lift and move the panel into the fixed jamb as far as possible. Verify that the weather stripping in the frame head is located so that it contacts the width of the “O” panel. Installing the fixed panel security screw: Using a 1/16” diameter bit, drill a hole into the fixed stile through the hole shown in Figure 31. Then insert a black #8 x 3/4” self-threading screw.

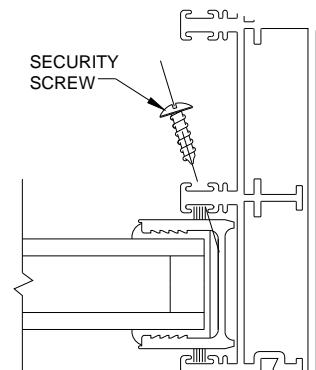

Figure 31:
“O” Panel security screw

Note: Installer to notch jamb filler to avoid damage that may occur from security screw

3. On pocket doors with an exterior pocket interlocker, move panel into the closed position; otherwise move panel into the wall pocket.
4. Repeat steps 2-3 until all panels have been installed. Panels must overlap during installation to allow proper engagement of interlockers (Figure 32).
5. Verify that all panels with interlocker hooks engage properly. If lead stile panel is not engaging properly with the jamb or meeting stiles, remove interlock spacers as necessary (Figure 32).
6. Install Head Fillers into the head tracks and Sill Fillers into the sill tracks (Figure 33).
 - a. Series 3070: Head and Sill Fillers are to be installed in all tracks where they do not interfere with the operation of the system.
 - b. Series 1070: Head and Sill Fillers are to be installed only in the "O" panel track.

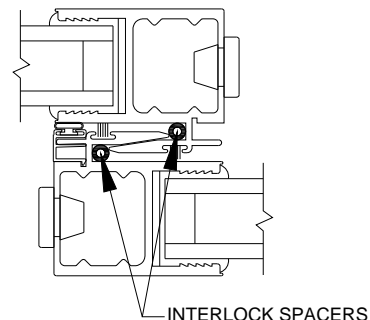

Figure 32:
Proper Engagement of Interlockers

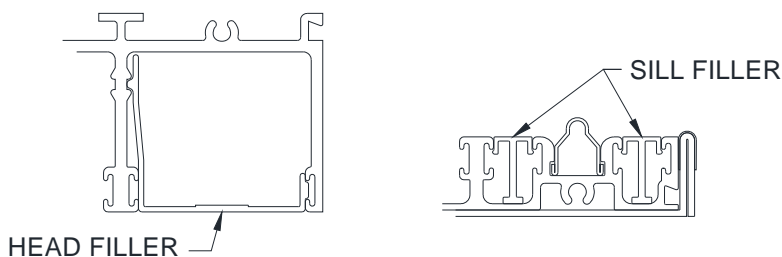

Figure 33:
Head Filler and Sill Filler

XVII. Air Barrier Installation (Optional)

After all panels have been adjusted plum and level and panels close and lock, open panels and install air barriers. Install Air Barrier (Figure 34) into the groove at the top and bottom of the exterior interlockers. Air Barriers bottom & top (Figure 34) are attached to all sliding interlockers and secured with (2) #6 x 3/8" long self-tapping screws.

Note: Optional to Improve Air and Water Performance, will increase friction when operating.

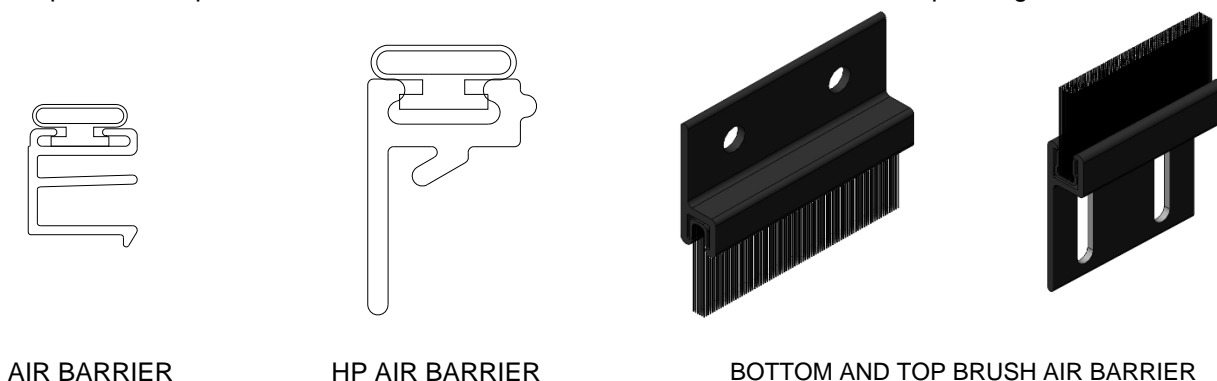

Figure 34:
Air Barrier Installation

Appendix A: 90° Lead Stile Roller Attachment (When panels are KD)

1. Remove the roller closest to the 90° lead stile from the bottom rail. Discard the attached screws.
2. Attach the roller to the 90° lead stile using 1/4-20 PHP Screws, 1" long located in the red bag (Figure A1).
3. Guide the roller into the bottom rail and secure using a #10 FHP screw, 5" long located in the red bag.

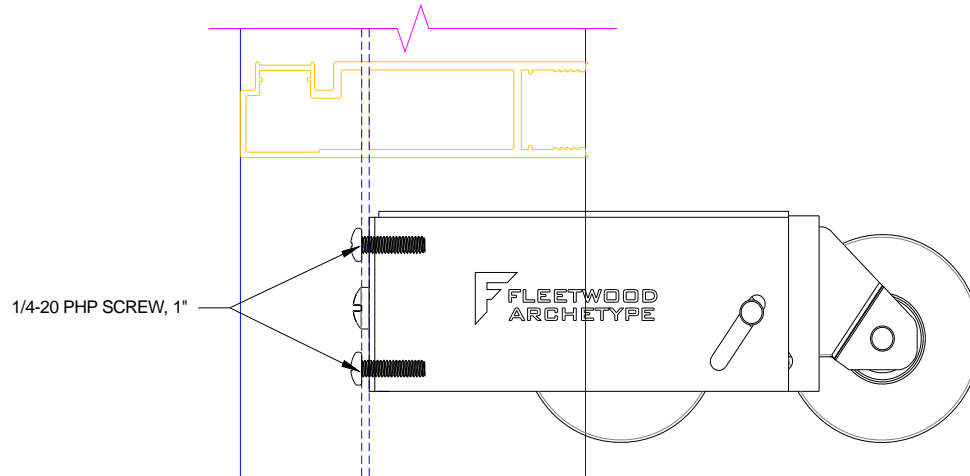
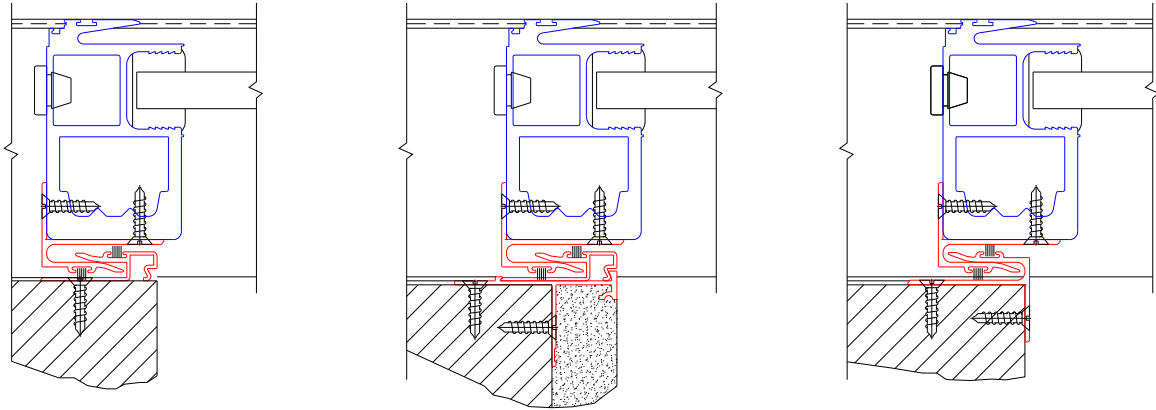

Figure A1:
90° Roller Attachment

Appendix B: Reverse HP Pocket Interlocker Installation

Note: This option allows HP stiles to pocket flush to your finished wall in the open position.

1. Panels are installed in the same manner as described in section “XI. Panel Installation”. The panel that interlocks to the pocket interlocker (Pocket Panel) will install into the 2nd track from the pocket interlock. The track closest to the pocket interlocker is a false track with sill fillers and head closers filling the entire length.
2. Adjust panel(s) prior to field cutting the L-Type interlocker that attaches to the panel.
3. The L-type interlocker is to be cut accordingly to minimize air infiltration. To fasten the L-type interlocker to the HP stile use #8 x ½” FHP screws 6” from the ends 18” on center through the back of the interlocker and through the side (Figure B1).
4. Install the brush air barriers to the top and bottom (optional).



J-Post shown

2-Piece shown

L-Type shown

Figure B1:
Pocket Interlocker Options with Reverse
HP Interlocker