

Table of Contents

I. Care and Maintenance	2
II. Tools / Materials, Sealant Requirements, & Anchor Instructions	2
III. Assembly and Installation	2
IV. Glazing Assembly	3
V. Panel Assembly (If panels were ordered glazed, skip to section IV)	3
"X" Panel	3
VI. Frame Assembly	5
VII. Structure Verification	6
1. Opening Verification	6
2. Pre-Fit and Leveling	6
VIII. Frame Installation	7
IX. Sill Track Installation	8
X. Sill Track Removal	8
XI. Pocket Closer and Head Bumper Installation	8
XII. Pocket Interlocker Installation	10
XIII. Pocket Interlocker Clip Installation and Removal	10
XIV. Panel Installation	11
Appendix A: 90° Lead Stile Roller Attachment (When panels are KD)	14

I. Care and Maintenance

This product is factory finished. Please handle with extreme care. Protect all exposed surfaces from contact with caustics, corrosives, solvents, abrasions, impacts, wet packing material etc. **FAILURE TO DO SO WILL NULLIFY THE WARRANTY.** Before **ANY CLEANING**, review the Care & Maintenance Instructions (go to www.fleetwoodusa.com for more information).

Contact the local dealer with any questions or concerns. Fleetwood strongly recommends that all products be cleaned after installation and totally protected from construction debris and equipment.

II. Tools / Materials, Sealant Requirements, & Anchor Instructions

Tools Required: Tape measure, Level, Shims, Screws, Screw Gun, #2 Phillips Bit, #3 Phillips Screw Driver, Power Drill, Sealant, Caulk Gun, Backer Rod, Utility Knife, Rubber/Plastic Mallet, Pliers, Wax.

Sealant Requirements

- The sealant referred to within this document for seals associated with the assembly of the product should conform to **AAMA 800**. It may be a sealant recommended and approved by the sealant manufacturer that is compatible with the framing, finish and surrounding materials.
- All sealant bead sizes must conform to the sealant manufacturers' size requirements.
- The Owner / General Contractor is responsible for identifying the need for any additional sealant to be applied by others. Such sealant shall be elastomeric material, with the framing, finish and surrounding materials.

Anchor Instructions

- Structural engineer to determine anchor quantity, size, and spacing for design load requirements.
- Proper material must be used between all dissimilar surfaces (i.e. block/concrete & aluminum).

III. Assembly and Installation

Note: Add tube wax lubricant to the ends of all fasteners to reduce the drive torque required for installation, apply a small amount of tube wax to the head of the fasteners to assist with installation.

It is essential that each Fleetwood product be assembled and glazed in accordance with AAMA standards and factory instructions. It is the installer's responsibility to ensure that each Fleetwood product is assembled, glazed and installed and completely sealed to ensure that the product is leak-free and operates correctly. **Installation of Fleetwood products must be in accordance with the standards set forth in ASTM E 2112.** If there are any questions regarding the installation of a Fleetwood product contact the factory customer service department.

IV. Glazing Assembly

1. Start attachment of glazing vinyl at top corner of the glass.
2. Cut glazing vinyl at corners as shown in Figure 1, Detail A.
3. At start/end point (seam), cut glazing vinyl 1/8" oversize to compensate for stretching.
4. Apply sealant to top portion of this seam.
5. Apply a bead of sealant that is compatible with the insulated glass seal to all four exterior corners as shown in Figure 2, Detail A.

Notes:

- a. The glass thickness, net width and height must be to size within $\pm 1/32$ ".
- b. Failure to install according to these instructions nullifies all warranties related to this product.

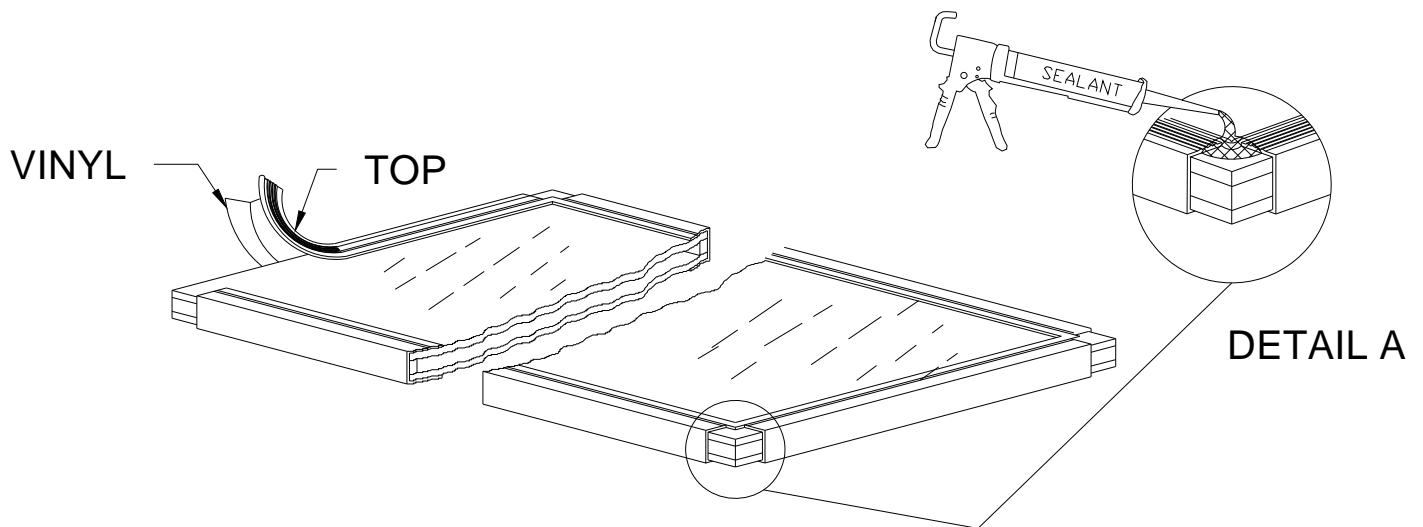

Figure 1:
Glazing Vinyl Application

V. Panel Assembly (If panels were ordered glazed, skip to section IV)

NOTE: Match door configuration and panel orientation with customer order. Configuration and orientation of panels shown in assembly instructions is for illustration purposes only. For attaching corner door stiles see Appendix A.

“X” Panel

1. Center the top rail onto the glass. Using a rubber mallet, drive the rail onto the glass until the rail seats against the vinyl lip. Repeat this procedure with the bottom rail.
2. Position the interlocker stile, weather-strip facing up (on the right for OX, left for XO) and drive it onto the glass.
3. Position the interlocker stile on the right side and drive it onto the glass.
4. Position the lead stile or interlocker stile on the left side and drive it onto the glass.

5. Secure the stiles to the rails with (4) #10 x 2" pan head screws (Figures 2). Add wax to the ends of all fasteners to reduce the drive torque required for installation.
6. Install (2) ¼-20 UNC x ½" long pan head screws to bottom of interlocker stile or lead stile. Screws attached vertical rails to Roller Housing (Figure 2).
7. On doors with meeting stiles, a stainless-steel cover is provided to cover the oblong holes at the bottom of the male meeting stile (Figure 3).
8. Adjust the roller assemblies (2 required per "X" panel) to the full up right position using the adjustment screw (Figure 4).

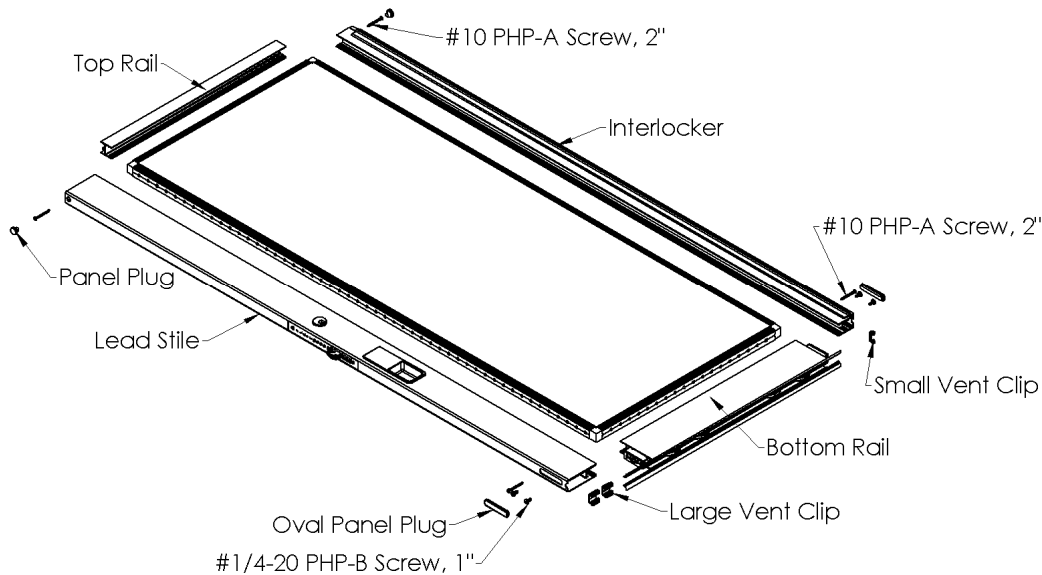

Figure 2:
 Stainless Steel Cover

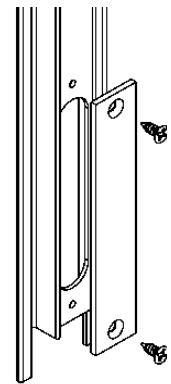

Figure 3:
 Stainless Steel Cover

Note: Before adjusting rollers, lift panels to relieve weight. Clockwise raises panel, counter-clockwise lowers panel.

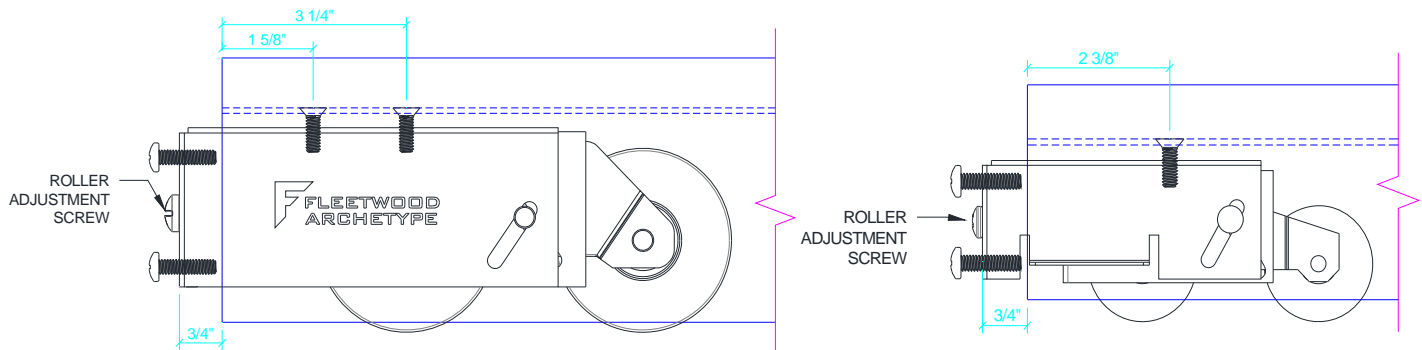

Figure 4:
 Roller Adjustment (A3 Roller Left, A2 Roller Right)

VI. Frame Assembly

1. It is recommended that one pre-drilled hole be added in each jamb(s) for use during installation.
2. Sill riser (optional 1" sill) is included, insert riser tab into sill pocket and slide together.
3. Attach the jamb(s) to the head using #10 x 3/4" long pan head screws (Figure 5). Make sure that the screws pass through the jamb(s) and into the screw races in the head.
4. To insure a square door frame, measure diagonally from corner to corner. When diagonal measurements are equal, the frame is square.

Note: The Series 3050 / Series 1050 Door was designed for interior applications.

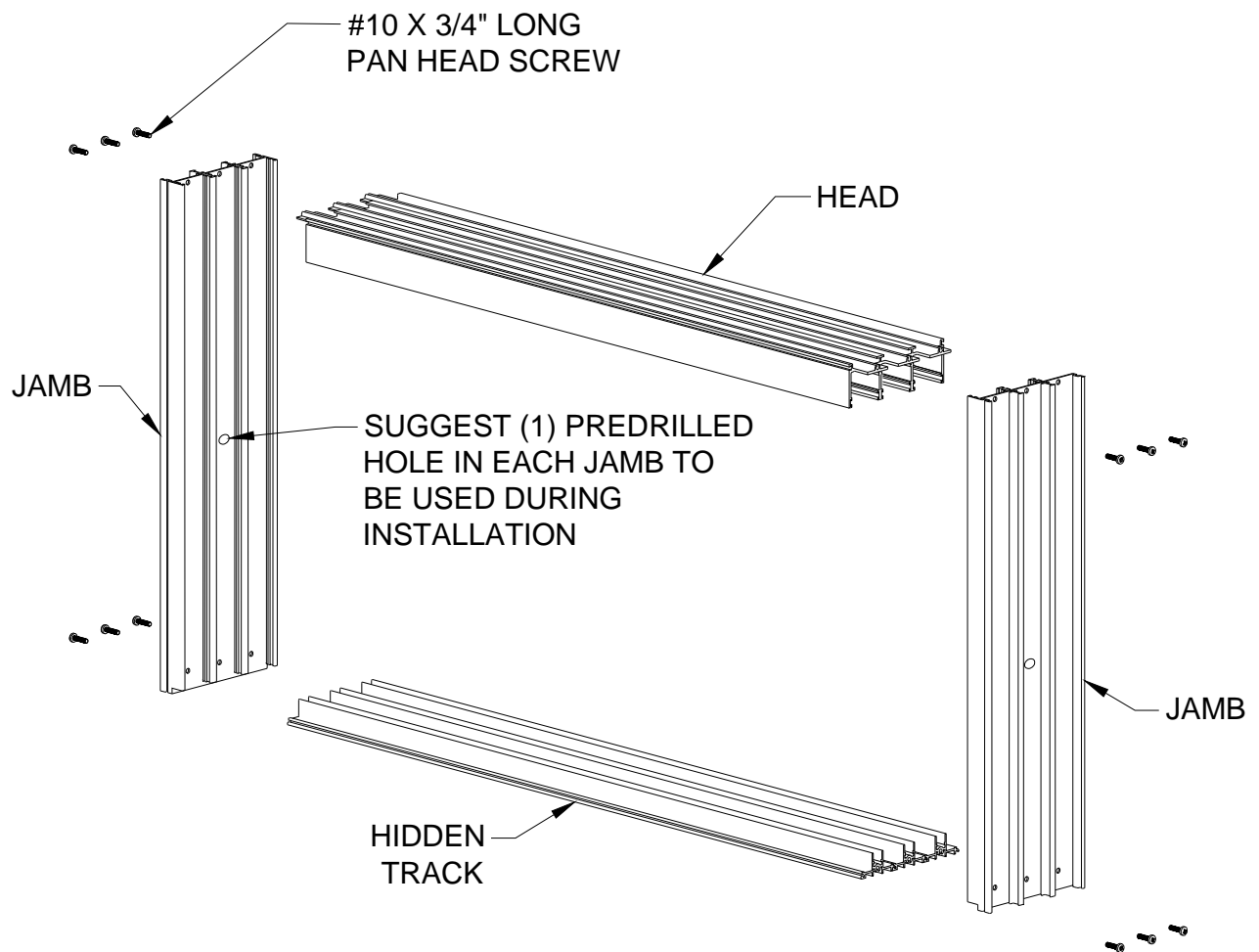

Figure 5:
Frame Assembly

VII. Structure Verification

1. Opening Verification

- Check the measurements of the opening and verify that the door will fit into the opening. Measure all four sides of the opening to make sure there is a clearance of 1/2" in width and 1/4" in height.
- Remove the door(s) from the packaging and lay it in front of the opening. Check width and height dimensions.
- Verify the opening is plumb and level.

2. Pre-Fit and Leveling

- Using the holes in the jambs place the frame inside the opening and determine any leveling that must be done prior to installation (Figure 6).
- Shim as necessary to stabilize the entire depth and length of the pan. No unsupported width of more than 8" is allowed. Shim to be load bearing, non-porous, non-absorbent and inorganic.
- If more than 1/8" shim height is required, it is recommended that pouring self-leveling "Rock Hard" (or equal) to achieve level and stable surface.

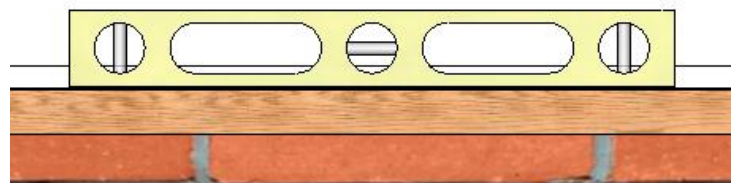
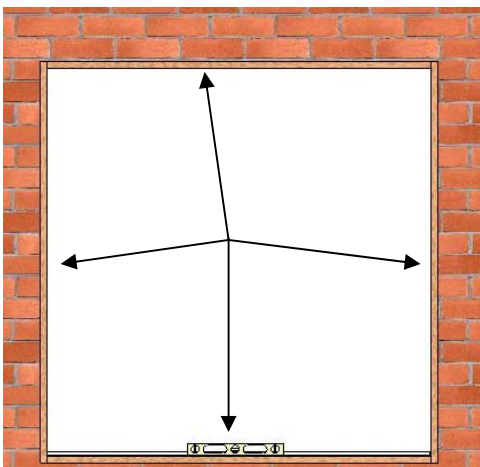

Figure 6:
Use level to determine if the opening is plumb and level

VIII. Frame Installation

1. Glue down the Sill with compatible sealant or secure by other means. It is the installer's responsibility to protect the sill from materials that may cause electrolysis.

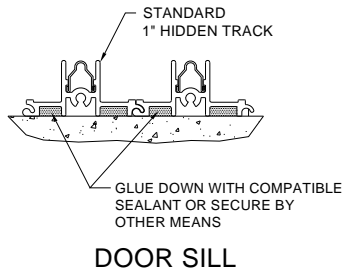
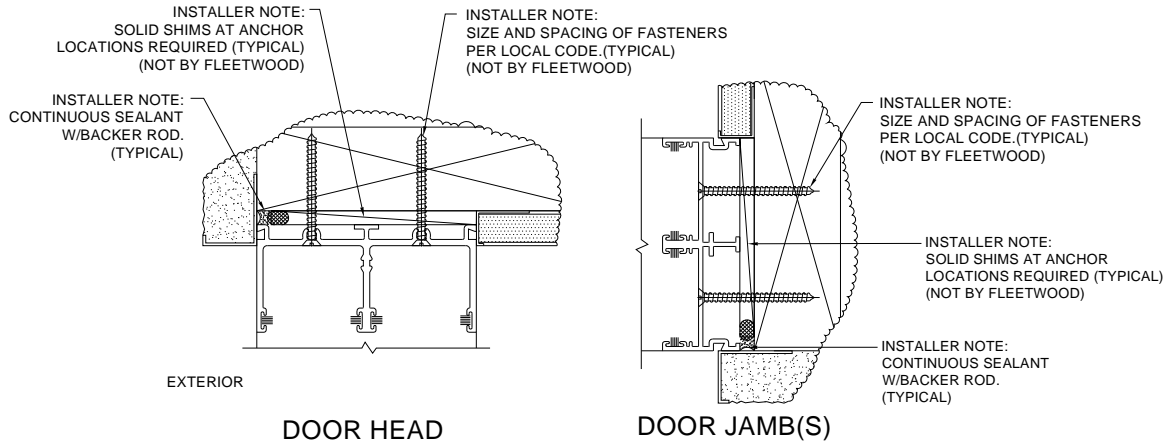

Figure 7:
Door Head, Jamb and Sill Anchor Locations

2. Attach frame to structure as shown below (Figure 7). On pocket doors it is important to locate the frame 3/8" from the inside pocket wall where a 2-piece and L-type Pocket Interlocker is used to allow for proper interlocking of panel with post interlocker. On installations where the J-Post Pocket interlocker clip is only used, a 5/16" distance is required. Figure 8 illustrates the different Pocket interlocker options.

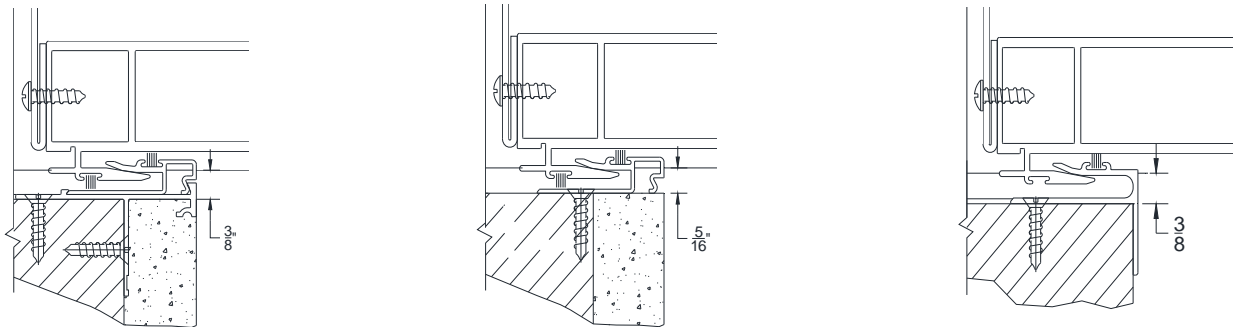

Figure 8:
Pocket Interlocker Options

IX. Sill Track Installation

1. Using a pair of pliers, slightly squeeze one end of the track to create a tapered edge.
2. Push tapered edge of track into the sill (Figure 9).
3. Using a rubber mallet, tap the track into the sill.

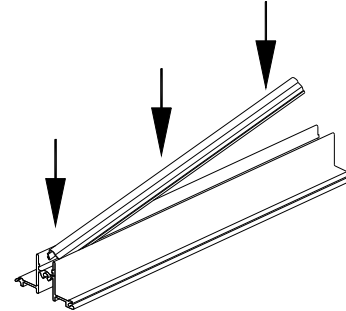
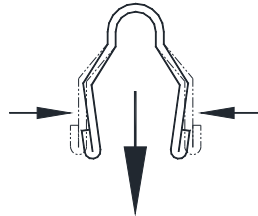

Figure 9:
Sill Track Installation

X. Sill Track Removal

1. Using a pair of pliers, slightly squeeze the track together at one end and pull up (Figure 10).
2. Using a screwdriver, slowly pry the track out of the sill. Although you can reinsert the track, we recommend a new track be installed for optimal performance of sliding door.

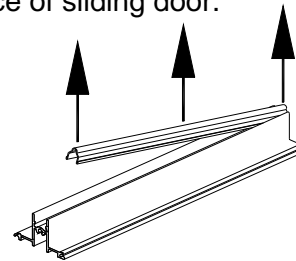
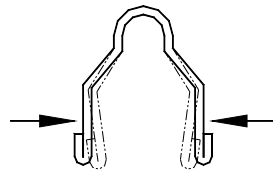

Figure 10:
Sill Track Removal

XI. Pocket Closer and Head Bumper Installation

1. A head bumper can be installed (Figure 11) in the head of each sliding panel track unless the panels contain door collectors, wind load adapters or high-performance extrusions. See the Multislide drawing provided at the time of the order for exact length and number of door bumpers.
2. If no drawing is available, use a 2-5/8" long head bumper for PX and XP configurations. For configurations with two or more glass panels (PXX, PXXX, etc.) use a 2" head bumper in the track of the longest panel. To determine the length of the head bumpers for the remaining tracks measure the width of each panel. Subtract the measured panel width from the longest panel width plus the head bumper length for that panel (either 2" or 2-5/8").

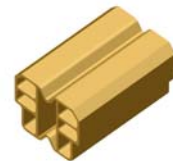

Figure 11:
Head Bumper

Example:

- Longest panel width is 47" plus the head bumper for that panel is 2", total equals 49".
- Subtract the measured panel width of other panels from the 49".
(49" - 45.62" = 3.38")
- The 3.38" dimension is the required bumper length for that panel.

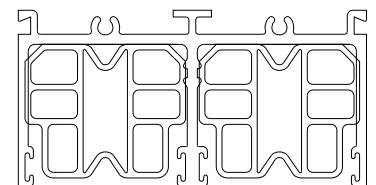

Figure 12:
Head Bumper Installation

3. Install head bumpers into head as shown (Figure 12).

4. Drill .136 diameter holes (#29 drill) thru pocket closer and one wall of interlocker. Holes to be located 6" from top and bottom of pocket closer, then evenly spaced on 12" centers. Assemble pocket closer to back side of interlocker with #10 x 3/4" long pan head screws (Figure 13).

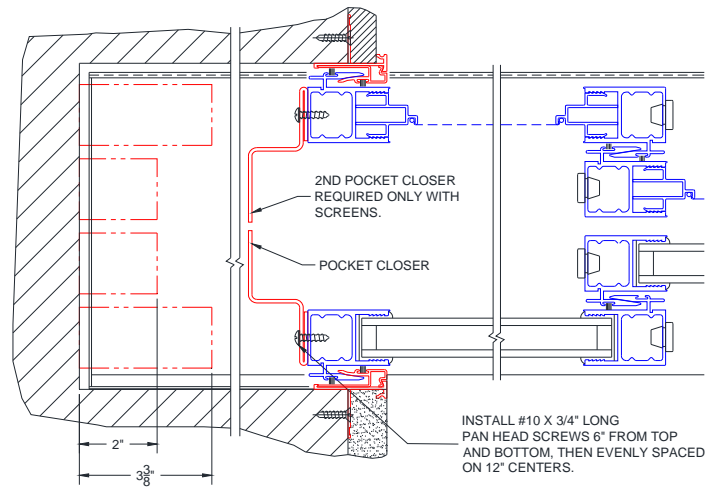

Figure 13:
 Head Bumper

XII. Pocket Interlocker Installation

1. Assuming that all door and screen panels will be installed from the exterior, the interior pocket interlocker is installed before any screen or door panels.
2. Pocket interlockers are furnished net frame height and must be field cut.
3. Attach pocket interlocker(s) with #8 flat head screws, not by Series. Install screws 6" from top and bottom with additional screws on 18" centers (Figure 14).

Note: PX and XP door panels can be taken out by removing the lock stile and the Pocket Interlocker clip attached to the frame. Dependent on the pocket interlocker type, removal of the wall may be necessary (Figure 8, Figure 14-16).

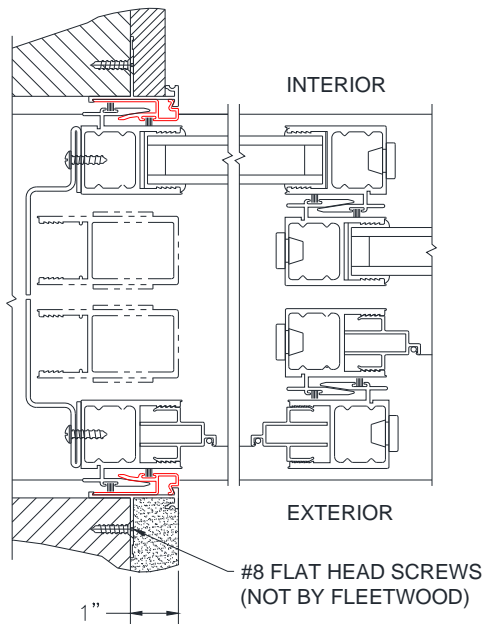

Figure 14:
Head Bumper

XIII. Pocket Interlocker Clip Installation and Removal

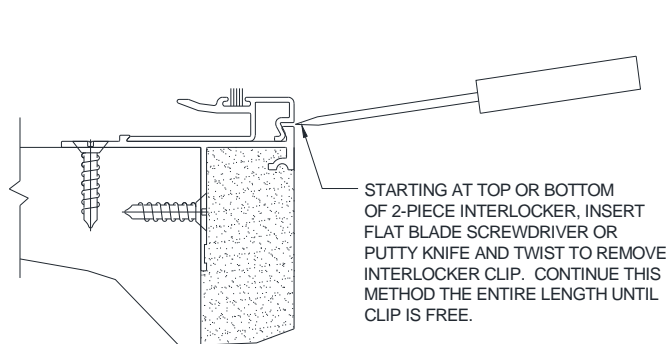

Figure 15:
Pocket Interlocker Clip Removal

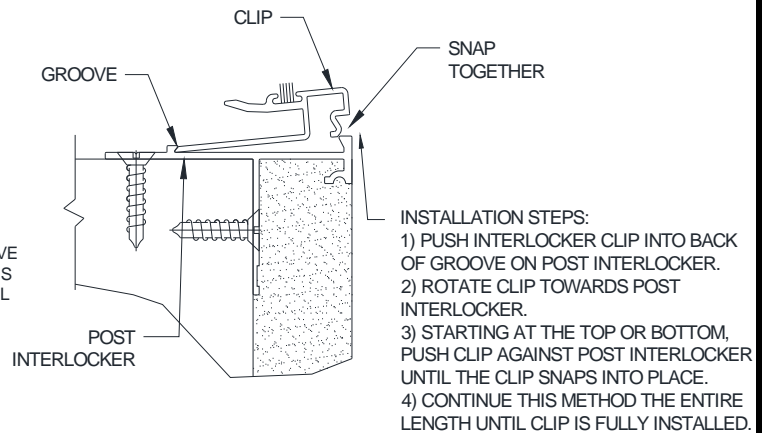

Figure 16:
Pocket Interlocker Clip Installation

XIV. Panel Installation

- Note:** a) Check customer order for proper panel configuration and orientation.
 b) Pocket walls: Installer to flash inside pocket walls to adequately protect from moisture.
 c) On pocket doors, installation of panels should be completed before construction of pocket is complete.

1. Sequence of panel installation is from interior to exterior.
2. Insert panel (panel located on the track closest to the interior) into the upper head channel (Figure 17). Push up and swing the bottom inward until panel is vertical, then lower panel down onto the track. On PX or XP configurations, if the pocket construction has been completed, it may be necessary to remove the lead stile from the panel before installation into the frame can be accomplished.

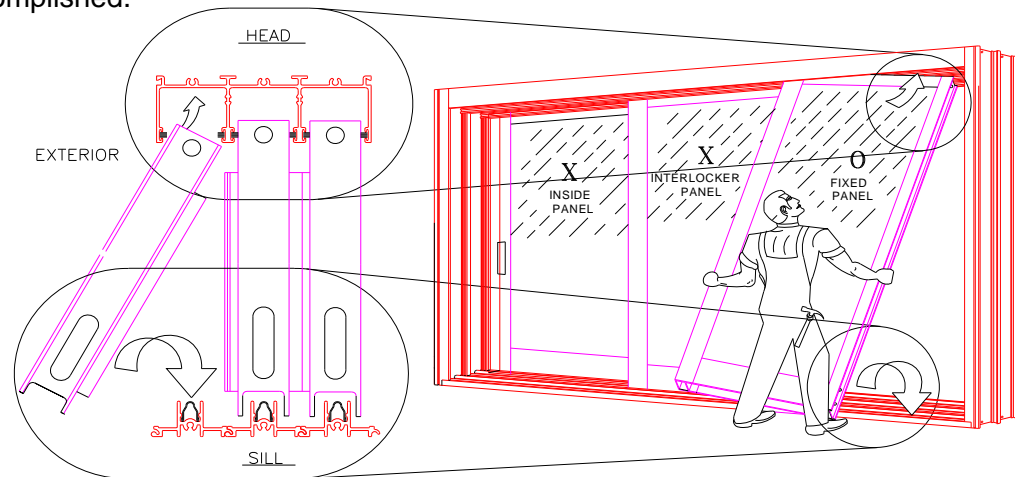

Figure 17:
Panel Installation

- **“X” Panel** - Do not attempt to slide the panel unless the rollers have been adjusted. Adjust the rollers as needed to make the panel plumb and level. If the panel contains a lock stile, verify that the latch height is correct for proper operation with the frame. Insert vinyl plugs into the holes at top and bottom of the panel.
- **“O” Panel** - Lift and move the panel into the fixed jamb as far as possible. Verify that the weather stripping in the frame head is located so that it contacts the width of the “O” panel. Installing the fixed panel security screw: Using a 1/16” diameter bit, drill a hole into the fixed stile through the hole shown in Figure 18. Then insert a black #8 x 3/4” self threading screw.

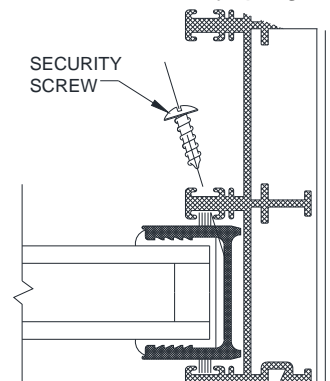

Figure 18:
“O” Panel security screw

3. On pocket doors with an exterior pocket interlocker, move panel into the closed position; otherwise move panel into the wall pocket.
4. Repeat steps 2-3 until all panels have been installed. Panels must overlap during installation to allow proper engagement of interlockers (Figure 19).
5. Verify that all panels with interlocker hooks engage properly. If lead stile panel is not engaging properly with the jamb or meeting stiles, remove interlock spacers as necessary (Figure 32).
6. When applicable, use a soft mallet to install Head and Jamb Fillers into all tracks where they do not interfere with the operation of the system (Figure 33).

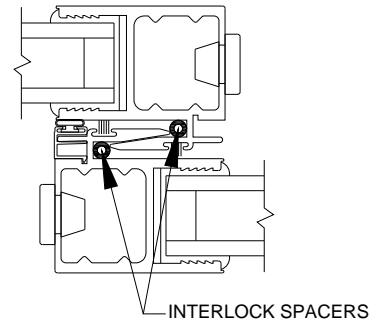

Figure 19:
Proper Engagement of Interlockers

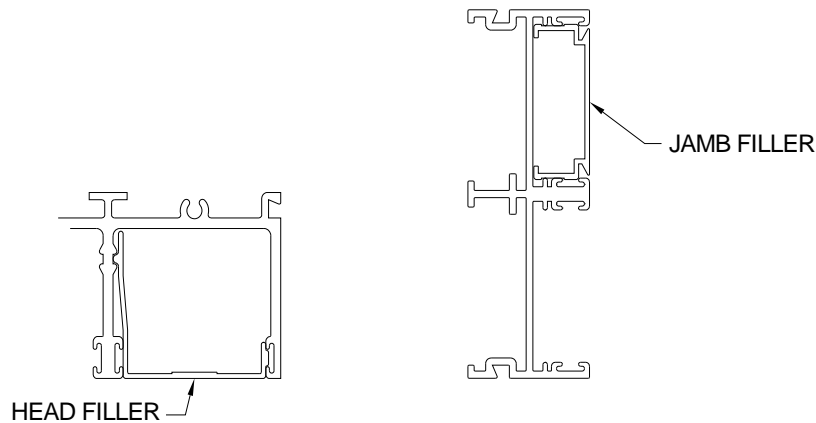

Figure 21:
Head Filler

XV. Air Barrier Installation (Optional)

After all panels have been adjusted plum and level and panels close and lock, open panels and install air barriers. Install Air Barrier (Figure 22) into the groove at the top and bottom of the exterior interlockers. Air Barriers bottom & top (Figure 22) are attached to all sliding interlockers and secured with (2) #6 x 3/8" long self-tapping screws.

Note: Optional to Improve Air and Water Performance, will increase friction when operating.

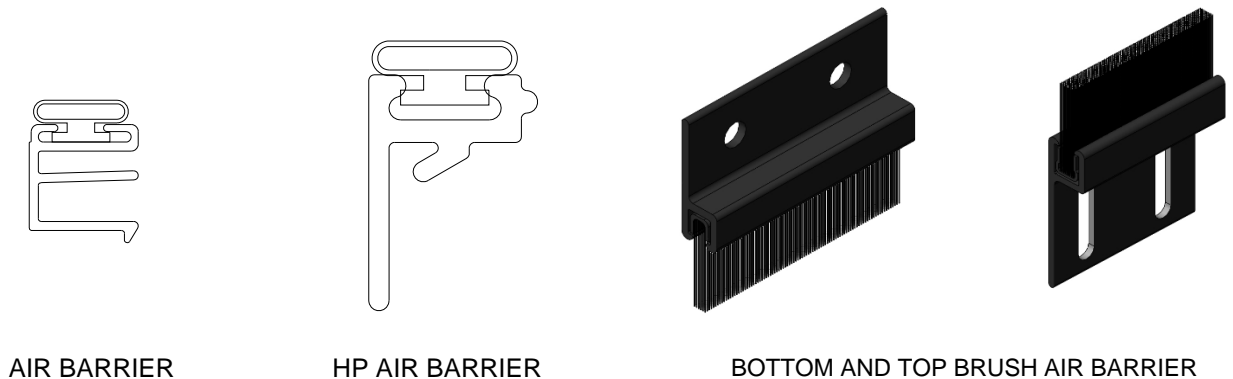

Figure 22:
Air Barrier Installation

XVI. Flashing after Installation

The flashing paper referred to in this document is Moistop or other code compliant flashing material that conforms to **Federal Specification UU-B-790a, Type 1, Grade A, Style 4**. The strips of flashing paper are to be no less than 9 inches wide (or wider as required by local codes). Flashing paper must be applied with galvanized nails or corrosion resistant staples. Flashing paper shall be applied in a weatherboard fashion around the full perimeter of the framed opening.

1. Once satisfied that the frame is water tight, and immediately prior to application of the flashing paper at the head and jambs, apply a continuous bead of sealant to the exposed mounting flange (nail-fin) at the top (head) and sides (jambs) of the installed frame. Also, apply sealant at corners of the frame, the full length of the seams where the nail fin flashing is mounted.
2. At each jamb, embed the flashing paper into the sealant onto mounting flange and fasten into place. The flashing paper should be cut sufficiently long enough to extend at least 3 in. past the weep-screed or diado flashing and at least 6 inches above the head of the window (Figure 23).
3. Finally, at the head, embed the flashing into the sealant on the mounting flange and fasten into place. The flashing paper should be cut sufficiently long enough to extend past the flashing paper at each jamb by at least 3 in (Figure 24).
4. Weather resistant building paper should be applied in a weatherboard fashion to complete the installation (Figure 25).

Note: Where weather resistant building paper, insulating board, or other materials by other trades may constitute the primary weather barrier behind the exterior wall finish (i.e. stucco, masonry, siding, etc.), the owner / General Contractor are responsible to ensure that the weather barrier is continuous by effectively sealing the material to the window frame.

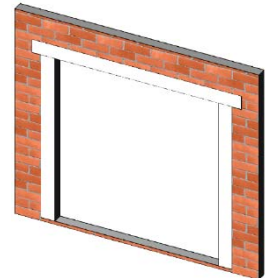

Figure 23:
Jamb flashing

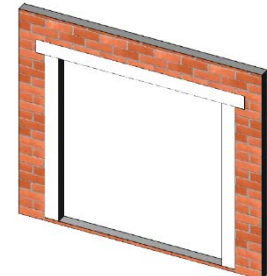

Figure 24:
Head Flashing

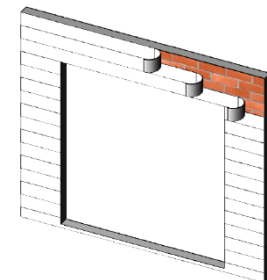

Figure 25:
Building Flashing

Appendix A: 90° Lead Stile Roller Attachment (When panels are KD)

1. Remove the roller closest to the 90° lead stile from the bottom rail. Discard the attached screws.
2. Attach the roller to the 90° lead stile using 1/4-20 PHP Screws, 1" long located in the red bag (Figure A1).
3. Guide the roller into the bottom rail and secure using a #10 FHP screw, 5" long located in the red bag.

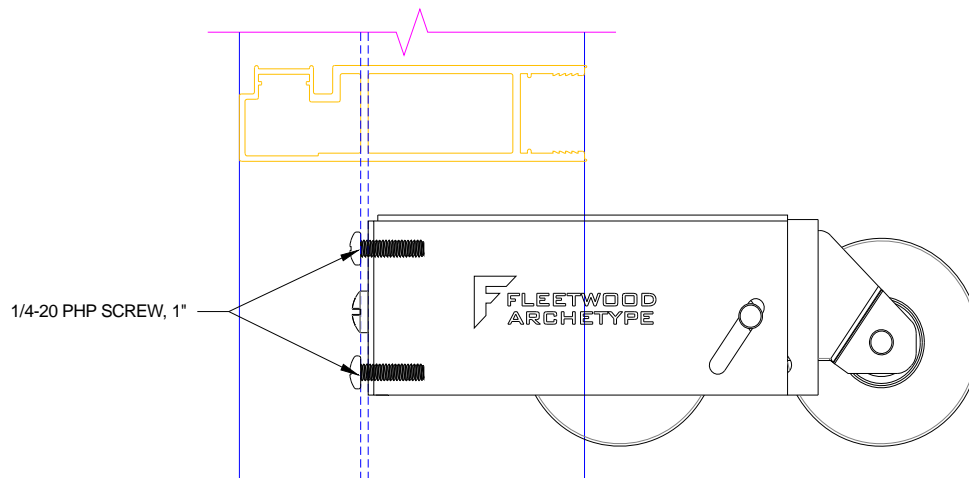

Figure A1:
90° Roller Attachment